

TOMO▶▶OWS

Urban fictions
for possible futures

Edited by
Daphne Dragona & Panos Dragonas

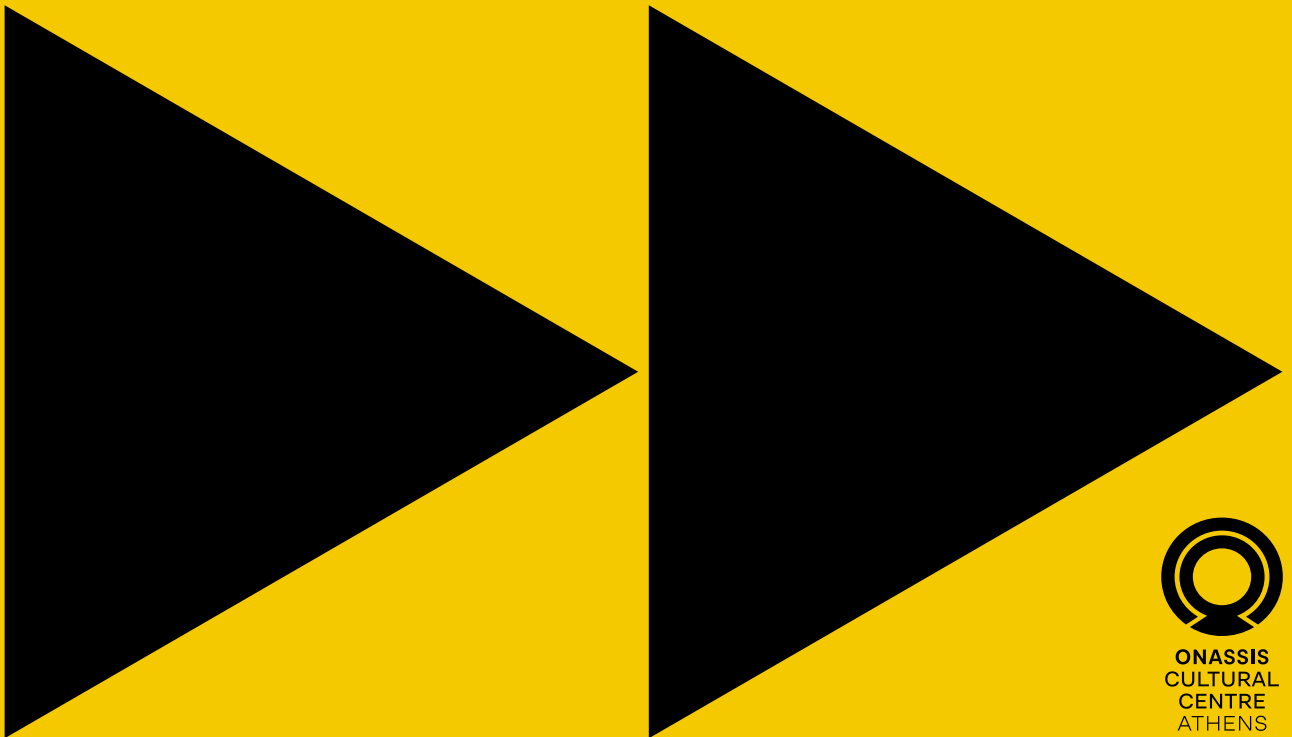

ONASSIS
CULTURAL
CENTRE
ATHENS

Tomorrows: Urban fictions for possible futures

Edited by
Daphne Dragona & Panos Dragonas

Publication copyright and similar rights: 2018, Onassis Cultural Centre–Athens

Essays copyright and similar rights: The authors

Individual projects copyright and similar rights: The artists

Exhibition photos copyright and similar rights: Mariana Bisti

Publication and essays: © ⓘ ⓘ Creative Commons Attribution ShareAlike 4.0 International

Individual projects and exhibition photos: © All Rights Reserved

ISBN

Printed version: 978-960-99774-8-7

e-book (.pdf): 978-960-99774-9-4

e-book (.epub): 978-618-83618-0-5



**ONASSIS
CULTURAL
CENTRE
ATHENS**

CREDITS

TOMORROWS: URBAN FICTIONS FOR POSSIBLE FUTURES

ORGANIZED BY

Onassis Cultural Centre–Athens

COORDINATION

Christos Carras

ORGANIZATION

Konstantina Soulioti

CATALOGUE

EDITORS

Daphne Dragona, Panos Dragonas

DESIGN

Yorgos Rimenidis – Grid Office

PHOTOGRAPHS

Mariana Bisti

PROOFREADING

Vassilis Douvitsas

This catalogue was published on the occasion of the exhibition “Tomorrows: Urban fictions for possible futures” at the Diplareios School Athens (May 16 – July 16 2017).

tomorrows.sgt.gr

Thanks to Mr. Apostolos Doxiadis, Mrs. Elina Zenetou, Mr. Dino Michalaros and Mrs. Giota Pavlidou for their willingness to provide and lend original material from the Constantinos A. Doxiadis and Takis Ch. Zenetos archives.

EXHIBITION

CURATED BY

Daphne Dragona, Panos Dragonas

ARCHITECTURAL DESIGN

Panos Dragonas & Varvara Christopoulou

TECHNICAL PLANNING AND CONSTRUCTION

TENSOR S.A.

(G. S. Papadimitriou & M. Pantelidaki)

LIGHTING

L4A “Lighting for Architecture”

AUDIOVISUAL INSTALLATION

Lefteris Karabilas (Technical Management)

Rebecca Stamou (Administrative Assistance)

Panagiotis Roniotis (Artworks’ installation)

IT

Kostas Apollonios

Yannis Chazakis

ELECTRICAL INSTALLATION

John Koutsoupis (Technical Management)

Eleni Keratsa (Administrative Assistance)

Dimitris Bougioukos, Nikos Issis (Electricians)

LINE PRODUCTION

Vassilis Panagiotakopoulos

LINE PRODUCTION ASSISTANT

George Linardakis

ARTWORK TRANSPORTATION

MOVEART S.A.

ARCHIVES DIGITALIZATION – ARTWORKS PRINTING

GRAPHICON – KYRIAKIDES A & N

VISUAL DESIGN

Beetroot

FRAMING

Nikos Sdralis

TRANSLATION – TEXT EDITING

Vassilis Douvitsas

PARALLEL EVENTS CURATED BY

Daphne Dragona, Panos Dragonas

PARALLEL EVENTS ORGANIZED BY

Iraklis Papatheodorou, Pasqua Vorgia

EDUCATIONAL PROGRAMMES CURATED BY

Myrto Lavda, Eleanna Semitelou

CONTENTS

8	PROLOGUE		
10	INTRODUCTION Future (un)follows fiction —— Daphne Dragona & Panos Dragonas		
16	Constantinos A. Doxiadis <i>Ecumenopolis</i>		
22	POST-NATURAL ENVIRONMENTS		
32	Shu Lea Cheang, <i>Mediterranean Touch Screen</i>		
34	Demetra Katsota & The Coastal Domains Option Studio, Department of Architecture, University of Patras, <i>Coastal Domains</i>		
38	Stefania Strouza & The New Raw, <i>Making Shores / Making Nature</i>		
42	Morehshin Allahyari & Daniel Rourke with ARTEKLAB, Geraldine Juárez, Darlene Farris-LaBar and Antonio Esparza, <i>The 3D Additivist Cookbook: On Mediterranean post-natures and the cultural now</i>		
48	Erich Berger & Mari Keto, <i>Inheritance</i>		
52	Design Earth, <i>Geographic Leviathan</i>		
58	Cathryn Dwyre & Chris Perry, <i>Transitional Environments</i>		
62	Postnatural Architectures: Design in the Anthropocene —— Cathryn Dwyre & Chris Perry		
68	SHELLS & CO-HABITATS		
78	Aristide Antonas, <i>Cave for an Unknown Traveler</i>		
80	Zissis Kotionis, <i>Hot_Camp: A Trans Urban block</i>		
82	Zenovia Toloudi / Studio Z, <i>Silo(e)scapes</i>		
86	Emma Charles, <i>White Mountain</i>		
88	Liam Young, <i>Tomorrow's Storeys</i>		
92	The Suspended City —— Bruce Sterling		
96	NETWORKS & INFRASTRUCTURES		
106	Takis Ch. Zenetos, <i>Electronic Urbanism</i>		
116	Kyriaki Goni, <i>The Aegean Datahaven: A collaborative platform in the archipelago</i>		
120	Michael Young & the Yale School of Architecture Advanced Studio, <i>The Icelandic Infrastructure 2036-2056</i>		
126	New Affiliates & Farzin Farzin, <i>Time Fears the Pyramids</i>		
130	Tobias Revell, <i>New Mumbai</i>		
132	This Must Be The Place: Critical Design and Urban Futurity —— Tobias Revell & Georgina Voss		
140	ALGORITHMIC SOCIETY		
150	Lina Theodorou, <i>a2525, Athens in S.F.</i>		
154	Point Supreme, <i>Tomorrows' Commons</i>		
156	Penelope Haralambidou & MArch Unit 24, Bartlett School of Architecture, UCL, <i>Cinematic Essays of Urban Futures</i>		
160	AREA – Architecture Research Athens, <i>Victoria: Way In / Way Out: The Shelter, the Embassy and the Transparent State</i>		
166	Metahaven, <i>City Rising</i>		
168	Vassiliea Stylianidou, <i>Hello! My name is B__ o _ _ _ _ _ _ _ _ d _ y _ _ and I am here to abduct the f__ut__u__ _ _ _ _ _ re__ _ _</i>		
170	James Bridle, <i>Homo Sacer</i>		
172	Infrastructures for Tomorrow's Urban Intelligences —— Shannon Mattern		
176	BEYOND ANTHROPOS		
186	Adam Harvey, <i>Stealth Wear</i>		
190	Ava Aghakouchak & Maria Paneta, <i>Sarotis: Wearable futures</i>		
192	Victoria University of Wellington, <i>Birthright</i>		
196	Lydia Kallipoliti, Andreas Theodoridis with Erica Vinson, Xueping Li, Dakota Pace and Seraphim Le, <i>Air Shake</i>		
200	Manolis Daskalakis-Lemos, <i>Feral Remnants (Dog)</i>		
202	!Mediengruppe Bitnik, <i>Ashley Madison Angels At Work in Athens</i>		
204	Pinar Yoldas, <i>The Kitty AI: Artificial Intelligence for Governance</i>		
208	Eight keywords for tomorrow —— Thomas Doxiadis		
212	EXHIBITION		
214	LIST OF EXHIBITED WORKS		
216	BIOS		

Narratives about the future, that extend or on the contrary, mute dimensions of our present world have proven to be powerful critical tools. They set thought experiments in motion that ask “what if?” and place us in front of utopias or dystopias that create a dynamic tension with our actual experience. All the works in the *Tomorrows* exhibition in Athens imagine future social, technological or environmental contexts, but retain a sufficiently identifiable relation to our lived present so as to make us question the dynamics of the world we inhabit. The selection of works has a slant towards a Mediterranean, or perhaps more generally southern, context whilst at the same time bringing to the fore critical issues of global significance. The narratives developed in these works take the form of material speculation: both as speculation about the material world and as speculations that manifest themselves materially, through works of art and design processes.

Tomorrows also adopts a multiple relation to time. There have, after all, always been tomorrows. A fundamental dimension of the project is a reflexion on the particularity of the speculative moment in relation to historical time. Two “anchor” points in the exhibition are the references to the, radically different, speculative projects of Constantinos Doxiades and Takis Zenetos. Focusing on their pioneering work enables us to understand both the fragility and the importance of visions of future worlds.

For the Onassis Cultural Centre, *Tomorrows* is a project that is firmly inscribed within an ongoing and multifaceted reflexion on the dynamics of our world. Working at the junction of the technologies that overwhelmingly mediate our social and personal lives and the formal, material and also technological work of contemporary artists, performers, designers and architects that reframes our understanding of the world, we hope to provide opportunities for new insights into our 21st century condition.

Tomorrows itself is an ongoing project and it is to be hoped that future iterations, in different places, will continue to hone critical thinking about where our world is heading and where we might conceivably want it to head.

Christos Carras,
General Manager, Onassis Cultural Centre

INTRODUCTION

Future (un)follows fiction

— Daphne Dragona & Panos Dragonas

Buckle your seatbelt Dorothy, 'cause Kansas is going bye-bye!
— *The Matrix*

The future never felt closer than it does today. A series of environmental, technological and societal changes happening at an accelerating pace are affecting today's world and the humans' role within it. As the urban population continuously rises, the Earth resembles a city which keeps on sprawling outwards, a city expanding everywhere with no limitations. Climate and the natural environment are irreversibly affected by the impact of anthropogenic activities, while new engineered ecologies are introduced to meet the increased needs of future inhabitants. Life in the urban environment is rapidly restructured as cities become 'smarter' thanks to the use of different machines-at-work capturing and processing human behavior. As diverse images, once belonging to the future, become more and more part of the present, an urge to engage with a contradictory and multifaceted upcoming reality emerges.

Tomorrows is an ongoing exhibition project which addresses the complexity of the future and unfolds its multiple aspects. Through works by artists, architects and designers, it introduces and discusses different scenarios about tomorrow's possible worlds speculating on the expectations and anxieties of their inhabitants. Hypothetical stories, exaggerated trends of the present and future visions of the past, invite the contemporary audience to critically reflect upon the ongoing changes and their possible outcomes. Non-existing cityscapes, future habitats and imaginary infrastructures come together with fictional structures, wearables and A.I. systems in order to challenge the humans' role on Earth and foreshadow their coming relationship with non-humans and the machines.

Of course, dealing with the future is not new in art and architecture. Renowned are the visionary architectural proposals of the 1960s which addressed the promises of the new networks, and the possibilities of overcoming urban and social problems thanks

to the technological advance. The excitement and innocence of speculative architects such as Archigram, who aimed to imagine and influence change towards a more desirable future, was juxtaposed to the critical approach of the Italian radical groups Superstudio and Archizoom. During the same period, Takis Ch. Zenetos worked on a lifelong research project about the city, the house, and the furniture of the future. In *Electronic Urbansim*, Zenetos foreshadowed the experience of a networked, immobilized human body that could be 'everywhere or nowhere.' His speculative work may be linked to 1960s megastructure projects such as Constant Nieuwenhuys' *New Babylon* and Yona Friedman's *Ville Spatale*. What distinguishes Zenetos from most speculative architects was his meticulous design approach that was based on systematic research and very good knowledge of the forthcoming scientific and technologic developments. *Tomorrows* exhibition presents Zenetos' original drawings and models for the first time since his death in 1977.

Nowadays, dealing with the future is once again timely but the new projects are in a somehow different context. Following an open call which received more than 300 proposals from all around the world, *Tomorrows* exhibition includes 30 new artworks and academic research projects coming from the fields of art, design, and architecture. In less anticipation of tomorrow's worlds, contemporary narratives rather start from the challenges and contradictions that shape the images of the future. Following the steps of the Italian radical groups of the 1960s, their scenarios are exaggerated, unexpected, and often paradoxical. From different starting points, with different media and approaches, their perspectives are introducing alternatives of what the city of the future may be. In their essay, Cathryn Dwyre and Chris Perry relate the generation of new narratives and the production of new concepts about the environment to the 'shock of the Anthropocene,' while Tobias Revell and Georgina Voss define speculative and critical design as a practice which aims to challenge and disrupt the dominant, seemingly inevitable imaginaries. In both cases *Tomorrows'* projects are aiming to provoke discussions and are using the future as a tool that can assist in critically understanding present itself.

As William Gibson has famously noted, the future reaches different geographical areas at a different pace. The popular projections to the future, through movies, literature and television, mostly refer to economically advanced megacities or urban agglomerations. The dominant vision of the 'smart city' usually refers to a Koolhaasian generic environment, ultra-modern and devoid of any historical narrative. The different geographical

particularities, the local economies, and the dynamic of citizens' involvement are often left out, shaping an idealized, sterilized imaginary for tomorrow's cities. In her essay, Shannon Mattern highlights the importance of the local intelligences and situated knowledges, already existing in the 'urban operating systems,' in the shaping of tomorrow's smartest cities. *Tomorrows'* speculative and critical perspectives are challenging the 'smart city's' visions by emphasizing the particularities of different areas and underlining the role of the local conditions and needs. Most of the projects are giving special attention to the cities of the Mediterranean region, whose future seems to be specified by the economic crisis, the climate change, and mass population movements. Speculations about the emergence and interconnection of environmental, technological and socioeconomic ecologies within its territory are offered as opportunities to understand the scalability of future-oriented phenomena, to raise awareness and possibly evoke change. In Liam Young's project *Tomorrow's Storeys*, a new video commissioned by the Onassis Cultural Centre, the overall structure of a future Athenian urban block has not significantly changed since the twentieth century. The exterior facades are still covered by graffiti, tags, and air-conditioning machinery, but the combination of an advanced sharing economy with the advent of new microrobotic technologies, has made possible the quick transformation and regeneration of the apartment interiors. Bruce Sterling's short story also speculates on the way that the smart infrastructures of future Athens often end up in a mess, as power failures affect the urban software. Both works, Young's video and Sterling's short story, are questioning the hegemony of the 'smart city' vision as any attempt to subject Athens to algorithmic control seems to be eventually self-defeating. As counter-narratives, they prescribe a possible future that does not follow the dominant fiction and urban imaginary.

The exhibition takes both as a starting and a reference point the *Ecumenopolis* by Constantinos Doxiadis, the city that by the 22nd century would have occupied the whole of the inhabited planet as a continuously evolving organism. According to the visionary urban planner's theory of the 'Ekistics,' the desirable development of the future city for the human and the environment would depend on the relation and balance between five fundamental elements, i.e. nature, anthropos [the human], society, shells, and networks. *Tomorrows* exhibition aims, through the different approaches of artists, designers and architects, to revisit these elements, the model of the 'Anthropocosmos' as Doxiadis named it, and explore how their development and possible transformations are re-composing the present and future. Five themes deriving from the five respective elements become, therefore, points of exploration:

- ▶ The emergence of *post-natural environments* discussing the consequences of climate change and human activity on earth's natural resources, as well as the challenges and the possibilities brought by the new engineered ecologies, the opening and radicalization of new technologies, and the connections between human and nonhuman space.
- ▶ The development of new types of *shells and co-habitats*, exploring how at the time of smart urban living, shelters for the nonhuman, living or machinic, also become of primary importance, and imagining therefore not only buildings for people with heterogeneous identities but also environments of co-existence and symbiosis.
- ▶ The sovereignty of *networks and infrastructures*, looking into their physicality and imagining the aesthetics provoked by their immateriality and omnipresence, highlighting issues of power being involved, and speculating about possible counter-infrastructures and new topologies that may emerge in the future.
- ▶ The challenges of an *algorithmic society*, discussing how daily life changes with systems of automation and algorithmic regulation, while reflecting upon relevant expectations of past utopias and exploring exaggerated scenarios about increased surveillance and the evolvment of the anthropogeography of future cities.
- ▶ The transition to a condition *beyond anthropos*, looking into emerging forms of inseparability between human and machine and their impact on bodily systems, focusing on technological companionship and the development of an artificial superintelligence that may supersede the human.

The balance between the five elements of 'Ekistics' seems to have been utterly lost, as we are experiencing the consequences of 'anthropocentrism' and of the separation of culture from nature. Humanity rapidly shifts into a post-natural realm, where the possibility of governance by a super intelligent A.I., as the cat imagined by Pinar Yoldas at the end of *Tomorrows* exhibition, may not be far away. Thomas Doxiadis in his essay suggests that this may be the right time to reflect on the post-posthuman condition. A new peculiar balance, between *post-natural environments*, *humans*, *post-humans and nonhumans*, *algorithmic societies*, *smart shells and co-habitats*, *networks and infrastructures*, may be found in the 22nd Century *Ecumenopolis*. But as the five fundamental elements are transformed, redefined, and reversed, one key and central question arises: Which future is, at the end, the one we want, and what will be our role within its formation?

Το μέλλον
The Future



«... η πόλη του μέλλοντος είναι ήδη υπό κατασκευή.
Η μεγάλη ερώτηση που προκύπτει δεν αφορά τις διαστάσεις,
τη δομή και τη μορφή, αλλά τη λειτουργία της Οικουμένης,
τον τύπο ζωής που θα δημιουργηθεί μέσα σε αυτήν.»

“... this city of the future is already under construction.
The big question that arises is not about its dimensions,
structure, and form, but about the function of Ecumenopolis,
the type of life that will be created within it.”

ECUMENOPOLIS 2080



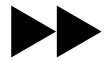

Constantinos A. Doxiadis



The theory of *Ecumenopolis* was developed by Constantinos Doxiadis' Athens Center of Ekistics as part of a research project for the "City of the Future" that was funded by the Ford Foundation.

According to Doxiadis, the great increase of urban population and the dynamic growth of cities will lead to their interconnection in a continuous network, into one universal city which we may call the ecumenic city, or *Ecumenopolis*. This is an inevitable reality that is already under construction and is likely to start acquiring shape at the beginning of the 22nd century. The big question that arises for Doxiadis is not about the dimensions, the structure, and the form of *Ecumenopolis*, but about its function, the type of life that will be created within it, and the quality of life that will offer to the people.

Doxiadis anticipates that the cities of the future will be extra-human, beyond human's capacity to control them. The world may be led to inhuman conditions as the problems and weaknesses of the 20th century's cities are multiplied. At the same time, he believes that *Ecumenopolis* may be "the real city of human" as for the first time in history, people will have one city rather than many cities belonging to different national, racial, religious, or local groups. *Ecumenopolis* will form a continuous, differentiated, but also unified texture consisting of many cells, the human communities. According to Doxiadis, this evolution corresponds to the dream of a cosmopolis, as the ideal state in which all people will be equal and united into one world.

The exhibition includes drawings, diagrams and photographs from the research project for the "City of the Future" where the theory of *Ecumenopolis* was developed, from lectures and publications by C.A. Doxiadis on the theory of Ekistics, and from the Delos Symposia that Doxiadis organized from 1963 to 1975. All material belongs to the Constantinos A. Doxiadis Archives.

© Constantinos and Emma Doxiadis Foundation

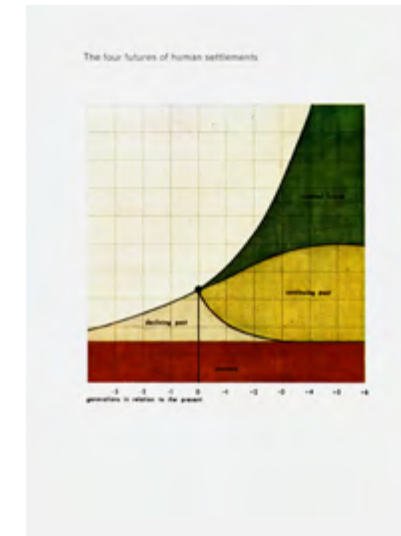
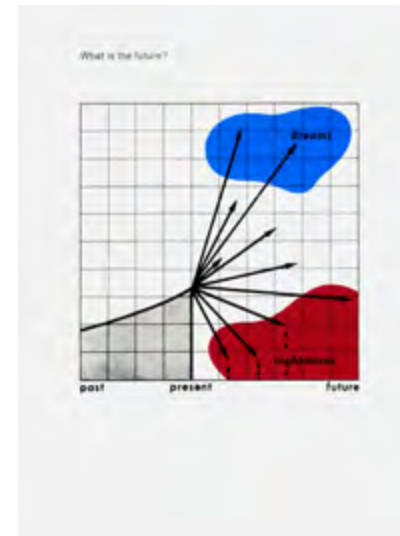

the 4 futures and 3 criteria approach

criteria	probable	desirable	possible
futures			
constant	red	white	red
declining	red	blue	red
continuing	red	blue	red
creative	white	green	red
total	red	green	red

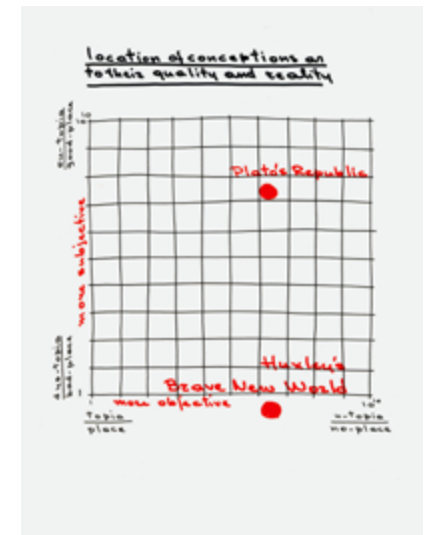
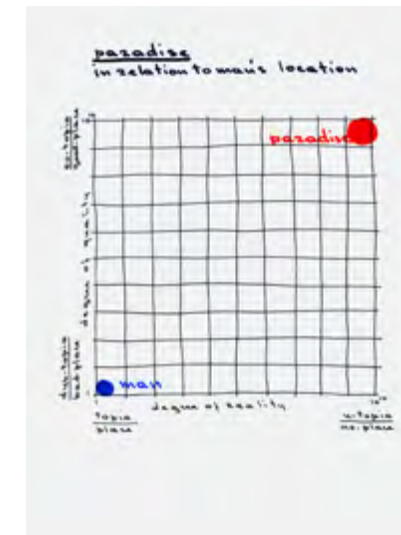
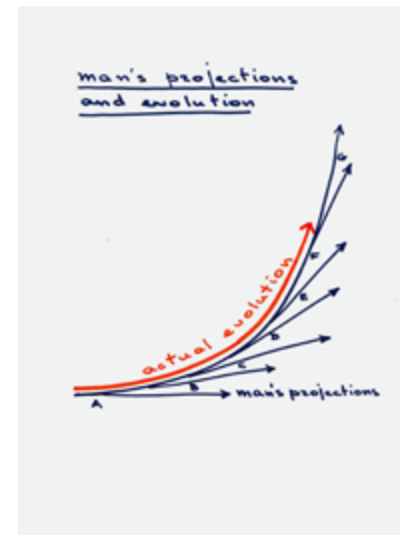

“ The future is an incomplete image, shimmering and shifting elusively, never quite the same. But it is by no means totally indeterminate. There exist definite limits to what might be, although the limits themselves are in a constant state of flux. As the present materializes, the indeterminate continuously becomes determinate, and [...] its addition changes the number of things which control the range of possible futures. ”

Constantinos A. Doxiadis and John G. Papaioannou, *Ecumenopolis: the inevitable city of the future* (Athens: Athens Center of Ekistics, 1974), 16.

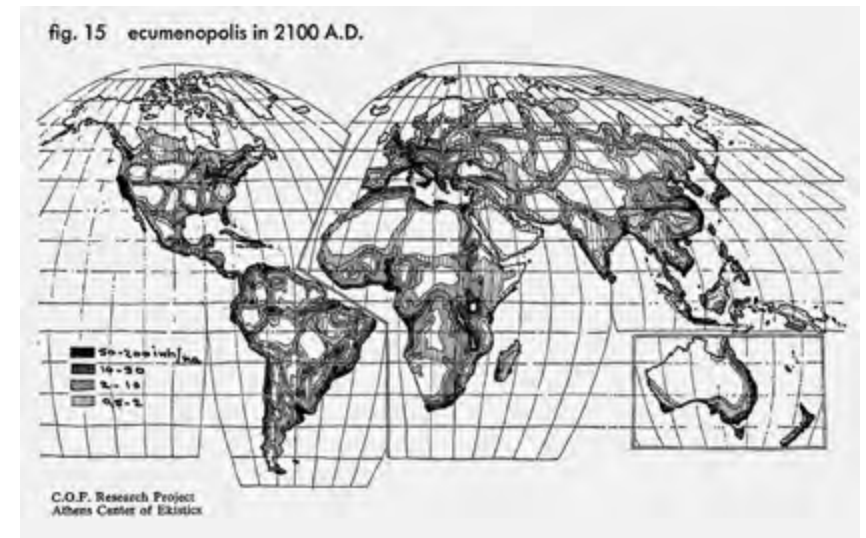
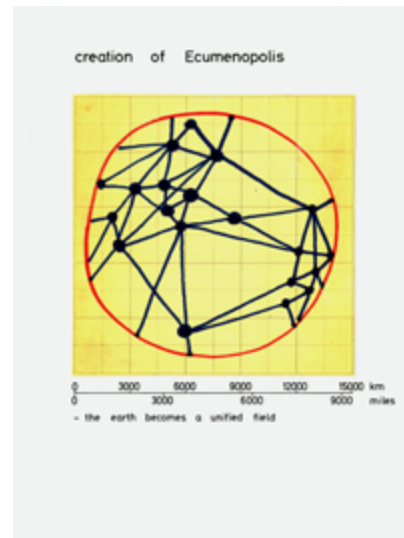
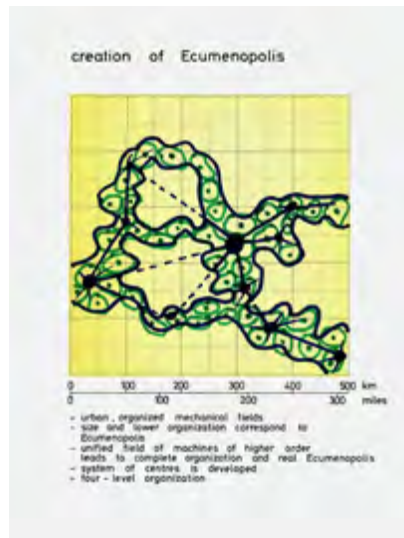
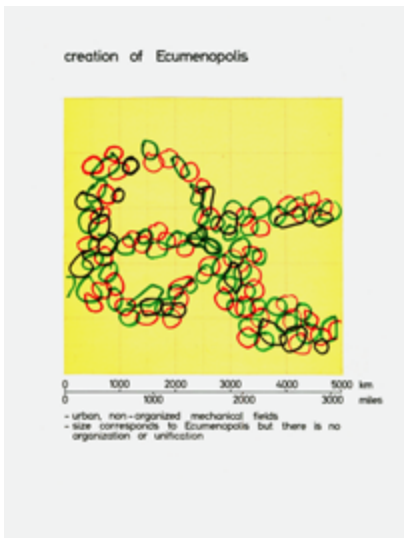
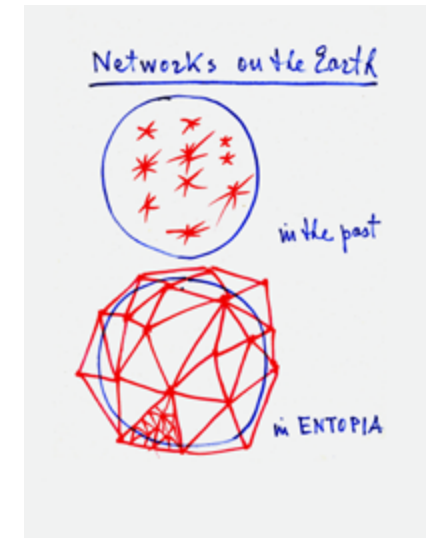
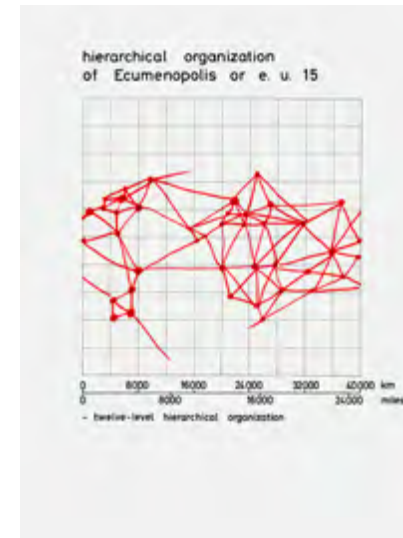
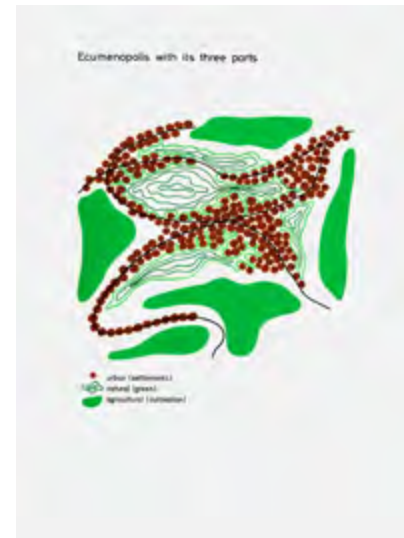
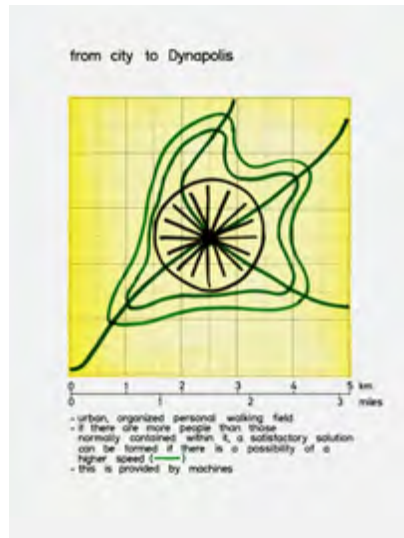
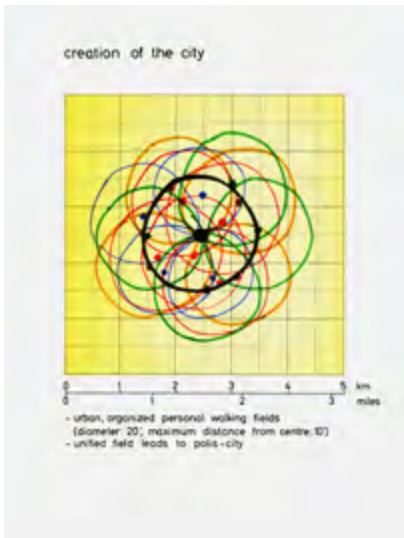

“ Such cities, growing dynamically over the next two or three generations, will finally be interconnected, in one continuous network, into one universal city which we call the ecumenic city, the city of the whole inhabited earth, or Ecumenopolis. If we speak, therefore, of the cities of the future one century from now, we can state that they will have become one city, the unique city of mankind. ”

Constantinos A. Doxiadis, "ECUMENOPOLIS: Tomorrow's City," *BRITANNICA Book of the year 1968*, Encyclopaedia Britannica, Inc.

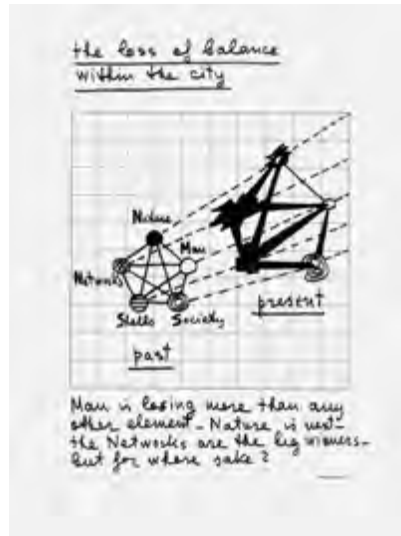
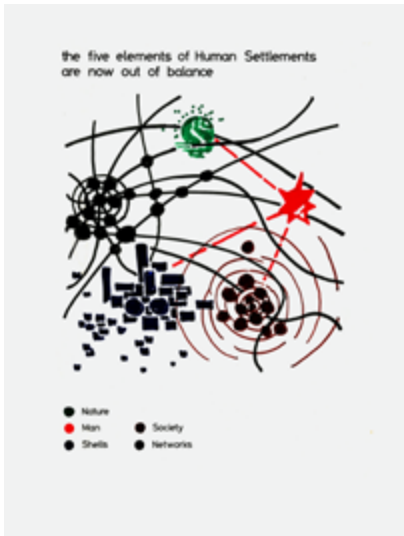
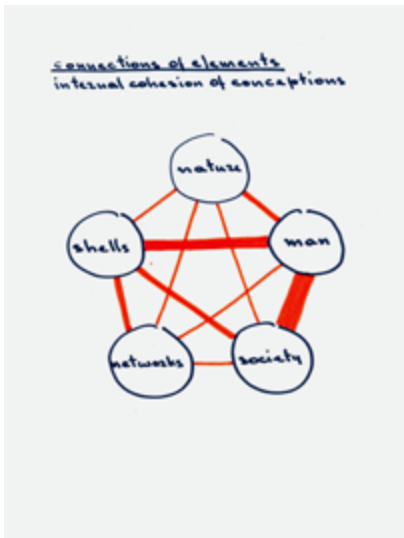

“...[W]e must achieve a state of balance between the five elements that make up human settlements – Nature, Anthropos, Society, Shells and Networks. [...] There is a complete lack of balance both with Nature and with Society, and above all Anthropos himself is out of balance with everything. Anthropos is losing the battle for harmony at present, but we don’t believe, as the pessimists do, that he will lose the war.”

Constantinos A. Doxiadis and John G. Papaioannou, *Ecumenopolis: the inevitable city of the future* (Athens: Athens Center of Ekistics, 1974), 383.

“ The city started with nature on which man came to build his society, to build his buildings, and then to create his networks of streets, water, and power. By now there is an interdependence of the five elements. We have a molecule, we don’t have atoms anymore. If you take anyone out, or if look at anyone alone, then you are completely wrong.”

Constantinos A. Doxiadis – Designer of *Entopia*, Edited by A. A. Kyrtis and G. Mavropsaridis (Constantinos and Emma Doxiadis Foundation, 2006), Video.



POST-NATURAL ENVIRONMENTS

22

The term 'post-nature' makes one curious but also anxious. *Why post-nature? What does the term imply?* The way one perceives the natural environment undoubtedly depends on the relation they develop with it. Today's sprawl of the cities as well as the acceleration of technological development makes the human imprint on the planet more and more visible. So, *what changed to what we knew so far as natural environment, and what is foreshadowed for its future?*

The exhibition hosts future landscapes capturing the ecological consequences of our contemporary way of living as well as scenarios for techno-natural environments that are developed, modified and controlled by the human. Different hypotheses are presented for the ways new systems and technologies can be used in order to balance the exploitation of natural resources, or to empower living organisms. Avoiding dystopian, or post-apocalyptic scenarios, the focus on post-natural environments aims for a new bridging between the artificial and the natural. At the same time, the projects underline the existence of the deep, geological time of the Earth, and the intertwining relationship between human and nature.



Shu Lea Cheang, *Mediterranean Touch Screen*, 2017.



Stefania Strouza & The New Raw, *Making Shores / Making Nature*, 2017.



Morehshin Allahyari & Daniel Rourke with ARTEKLAB, Geraldine Juárez, Darlene Farris-LaBar and Antonio Esparza,
The 3D Addivist Cookbook: On Mediterranean post-natures and the cultural now, 2017.



Small text block on the right wall, possibly a label or description.





Shu Lea Cheang



I don't see highrise. I see the Mediterranean cities floating in a sea of plastics. I don't see the cities getting smarter, I see the debris of parts, bits, bytes, pixels chasing after extensions, plug ins to get to the terminals. I see the clouds falling off the sky and there's no sign of raindrops falling.

Mediterranean Touch Screen is an imaginary sea landscape composed of broken keys and keyboard membranes. The numerous membranes float in the idyllic blue Mediterranean while the pebbled beaches made of broken plastic keys beam seductive toxic green. The work is a networked reactivated installation; the USB ports of the membranes are rewired, interlinked and connected to a system computer where sound data of Mediterranean remembrance are archived. The transparent membranes jointly serve as a post-digital touch screen for public interfacing. Visitors are invited to touch the membranes to retrieve sound notes from the stored data. The multiple sound notes generated offer a collective (de)composition of the syncopated tunes of bygone tomorrows.

Project team:

Shu Lea Cheang with Marinos Koutsomihalis (sound data); Julien Ottavi / APO33 (system patching); Alexandros Drymonitis (technical support)

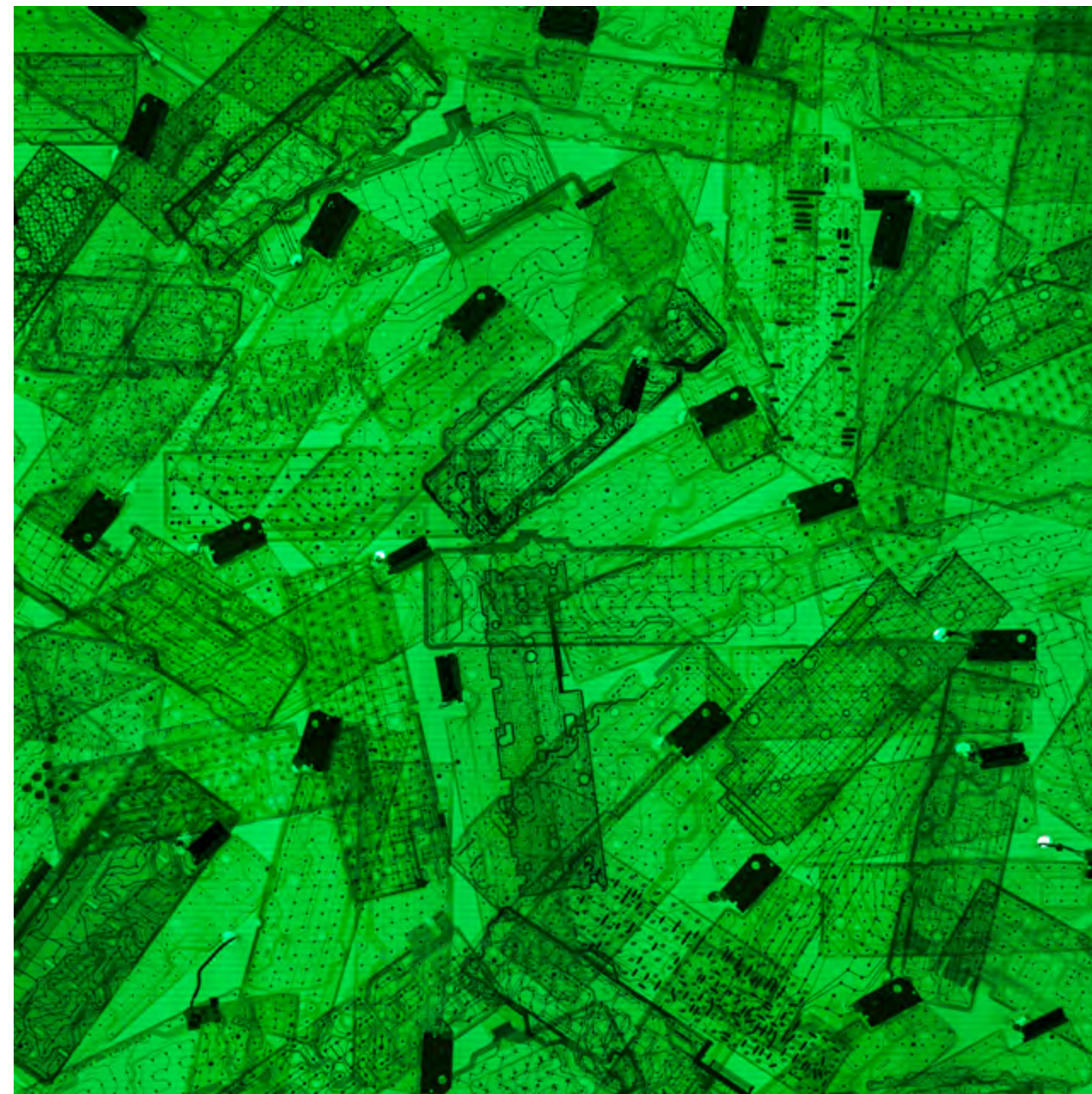

Opposite page: Installation drawing.

Above: Installation detail. Photo by Mariana Bisti.



Demetra Katsota & The Coastal Domains Option Studio, Department of Architecture, University of Patras

Project team:
Coastal Domains Research Team:
D. Katsota (Research initiator & team leader); K. Petrakos (Research coordinator); A. Biza (Research associate); E. Akiozoglou, M. Alexiou, S. Andronikou, Ch. Athanassiou, A. Biza, M. Daskalopoulou, N. Georgopoulou, I.A. Giannopoulos, M. Horsch, S. Kakalis, M. Kalaitzaki, A. Karkoulia, I. Karoutzou, S. Kontinou-Chimou, I. Levendi, P. Maragkakis, E. Nikolaou, F. Panagopoulos, M. Papadea, F. Papadopoulos, A. Papamichalopoulou, A. Ritsoni, K. Roussou, Th. Serdari, K. Smagulova, K.A. Sofianidi, A. Stakia, I. Trikogia, A. Tzoutsas, A. Xenouli, A. Zachariadi (Research team members)
Installation & Publication Design Team: buerger katsota architects / Stephan Buerger, Demetra Katsota with Anna Biza, Savvas Kakalis, Alexandros Tzoutsas

coastaldomains.org



The *Coastal Domains* installation gives snapshots of an on-going design research process envisioning possible futures for the coastal territories of the Northeastern Mediterranean. These futures are presented in the form of sixteen books. The visitors reveal the content of the research by physically engaging with the artefacts. *Coastal Domains* is a multiyear collaborative research and education project at the University of Patras. It includes multiple case studies initiated on 1.0x1.0km coastal contexts. Through systematic mapping analysis, data collection and recording, the initiative is exploring, unveiling and assessing poignant contemporary issues of coastal development, tourism, environment, even education and employment, envisioning cohesive strategies for the design and management of a more sustainable, future Mediterranean.

Coastal Domains assembled works operate and broadcast in the form of atlases, panoramas, and an online platform. The atlases constitute cartographic, drawing and data archives of geographical, territorial, morphological, ecological conditions and transformations of various infrastructural, wetland, urbanized coastal contexts at present time. The panoramas are tactical programmatic and design speculations for managing ecological, urban, socio-economic challenges in a possible future. The online platform is an archive and networking tool to consolidate, link and make public academic research and activities, design projects, references and data.



Oposite Page: Mosaic of sites, 2017.

Right: Alexandra Zachariadi and Stephania Kontinou, *Issues and Pressures, Rehabit-at, Marathonissi, Zante, 2016.*

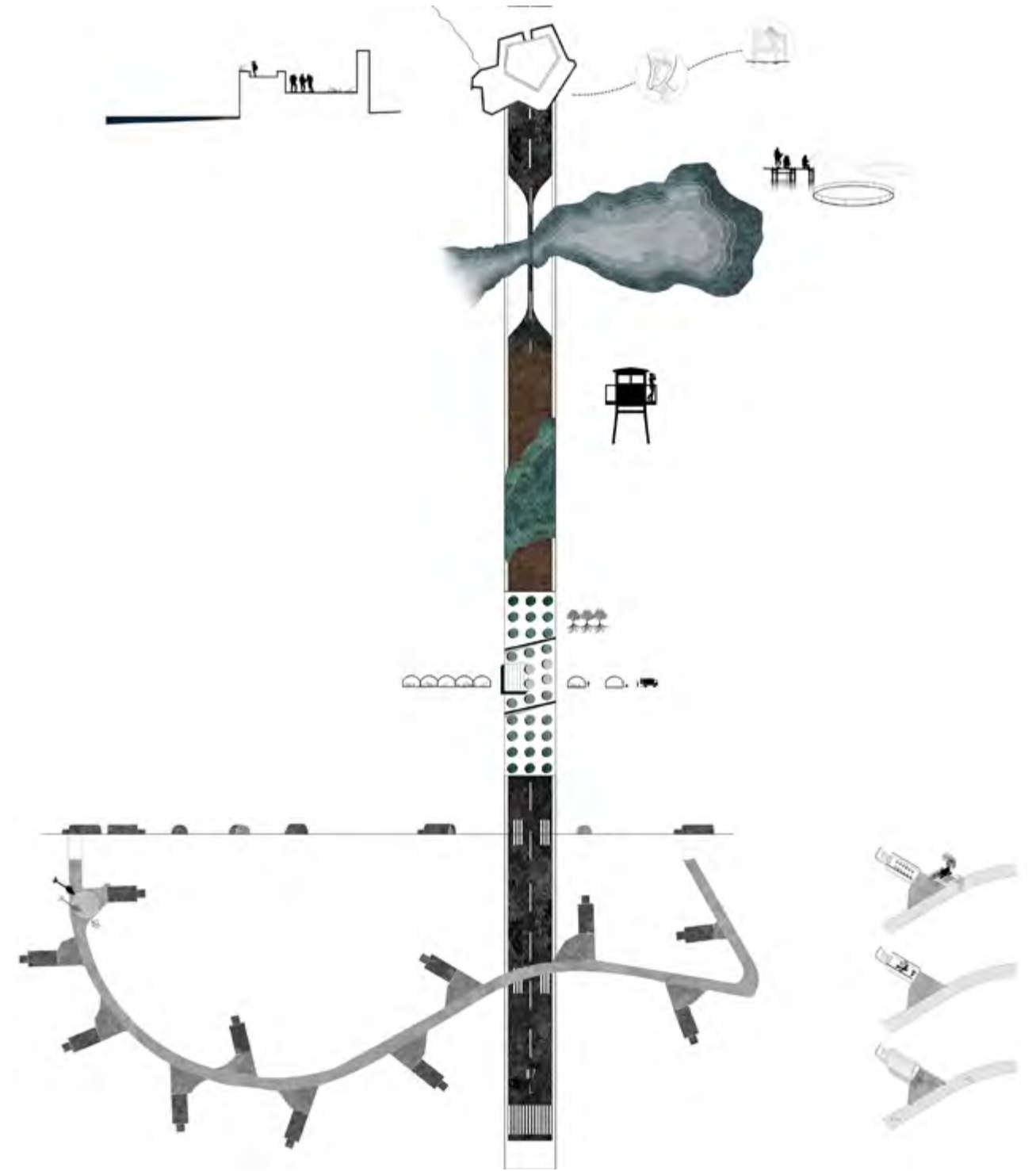

Oposite Page: Savvas Kakalis and Alexandros Tzoutsas, *Flooding Measuring Tools, Palus Intesio, Schinias, Attica*, 2017.

Above: Anna Biza and Konstantina Sofianidi, *Strategic Diagram, Forward Operations, Actium, Aetolia*, 2016.

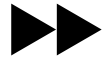

Stefania Strouza & The New Raw



The rising sea levels and coastal erosion of the Mediterranean shoreline have put the future of its cities into question. *Making Shores / Making Nature* proposes a rescue scenario for the Mediterranean ecosystem through the artificial lowering of the sea levels and aims for a new topography thanks to a combination of anthropogenic, technological and natural drivers of change. By entangling the coastal territory and its materiality into an exaggerated sci-fi framework, the project speculates about the environmental consequences of a future when nature and landscape will be manmade. *Which new spatial relations will surface in the previously submerged terrains of the Mediterranean? What material data can be revealed in these futuristic shores? Can these composite substances give birth to a new material technology in an era of resource depletion?*

Making Shores / Making Nature explores these questions, through engaging with the processes of material scavenging and of 3D prototyping nature. The work is a 3-part visual essay consisting of a publication on the process, material fragments of the new shores and 3D prints of the new seascape units, based on the form of a Mediterranean seashell.

Project team:
Panos Sakkas, Foteini Setaki,
Stefania Strouza



Opposite page: The three lives of the Mediterranean.

Above: The new shores.



Material fragment of the new shores and 3D print of the new seascape unit. Material: Recycled plastic. Techniques: moulding / 3D printing.



Top: Digitally crafted nature.
Bottom: Material making.



**The 3D Additivist Cookbook:
On Mediterranean post-natures
and the cultural now**

2017

**Morehshin Allahyari &
Daniel Rourke with
ARTEKLAB, Geraldine
Juárez, Darlene Farris-
LaBar and Antonio
Esparza**



The era of human scale art and design may be over. Increasingly, we need forms of intervention that take into account the deep, temporal impact of material processes and practices. Whilst developing planetary modes of vision, communication, and control we have altered the very ecosystems we seek to assert mastery over. In rendering the entire Earth an object of scientific study and commercial interest we have become implicated in the deep futures of every organism that grows, crawls, and blooms on its surface. Alongside this our economic and social systems have become so entwined with the natural order we separate ourselves from, that they have begun to evolve like organisms themselves, mutating beyond our capacity to understand them. As Richard Pell and Lauren Allen outline in their definition of ‘post-nature,’ human beings inhabit a world where organisms, their habitats and evolutionary niches, are “no longer determined simply by ecological pressures, but by an ongoing negotiation between commerce, regulation, and genetics,”¹ a relationship that, we argue, increasingly works both ways.

Beginning from their contributions to *The 3D Additivist Cookbook*, artists Geraldine Juárez, Antonio Esparza, Darlene Farris-LaBar, and the collective ARTEKLAB, offer works for this exhibition that probe the concept of the post-natural. The works intervene on synthetic/natural, technological/cultural boundaries using 3D fabrication as a tool for critical, poetic, and playful activism. Each work tackles questions of significant contemporary relevance to the Mediterranean region from ludicrous dystopian futures, offering post-natural hybrids as conduits for ‘weird’ forms of political engagement that might have a chance of altering our understanding of the cultural now.

¹“Out of the Lab, Into the Wild – Center for PostNatural History.” <http://postnatural.org/Out-of-the-Lab-Into-the-Wild>. Accessed January 11, 2016.

The 3D objects were produced especially for the exhibition by the artists, Decode fab lab and Shapeways.

additivism.org

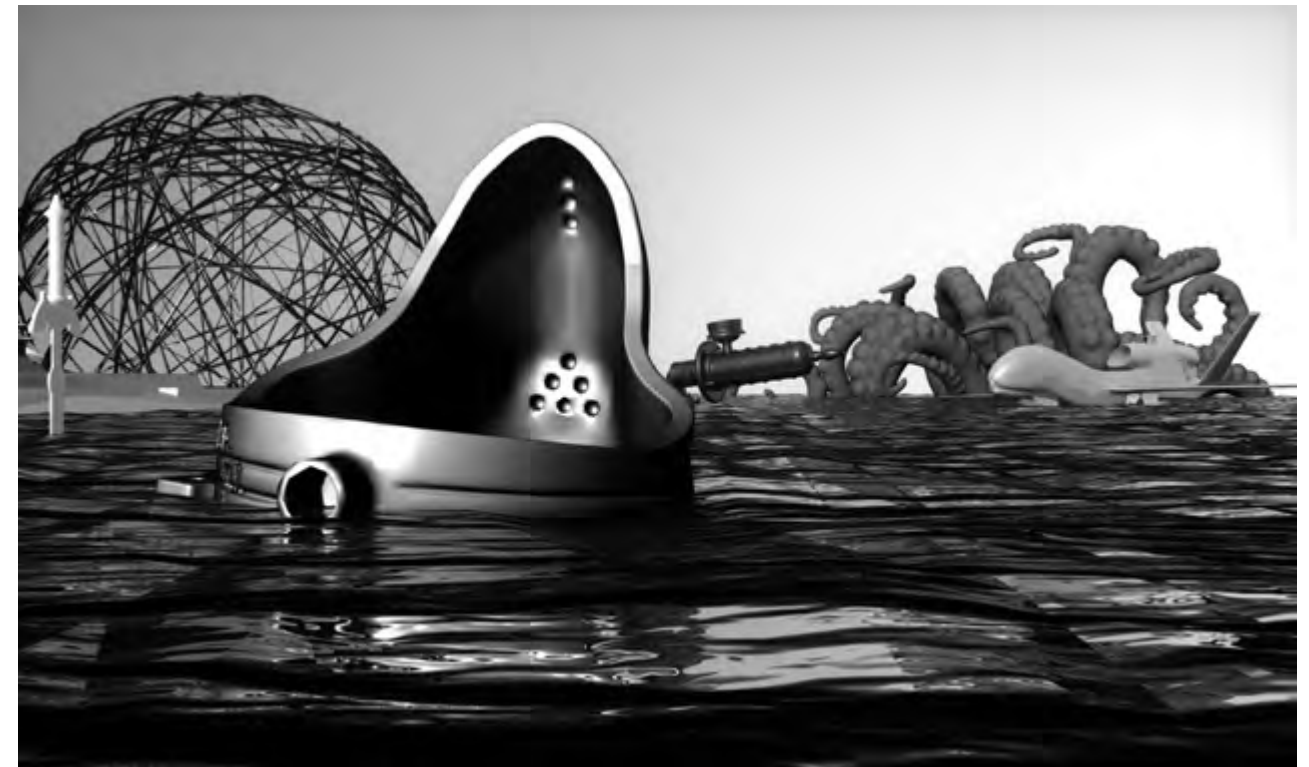

Top: Models, animation still.

Bottom: Morehshin Allahyari and Daniel Rourke, *The 3D Additivist Manifesto*, with sound design by Andrea Young, 2015.



ARTKELAB, *USOA 1.0 (Ultimate Software Open Animal)*, 2015–2017.

In a society where all communication channels and user access technologies are compromised, can global historical media, like carrier pigeons, be adapted to the present? *USOA* updates the function of pigeons as messengers through a 3D printed exostructure that can protect them on their mission.



Geraldine Juárez, *Kauri*, 2015–2017.

Seashells are crucial to understand the effects of the acidification of the oceans, produced when carbon dioxide released from human activity dissolves in the sea. Seashells have also been used by different cultures, as currency for trading goods. Featuring real and 3D printed shells, the project highlights how global economy is directly related to today's ecological consequences.

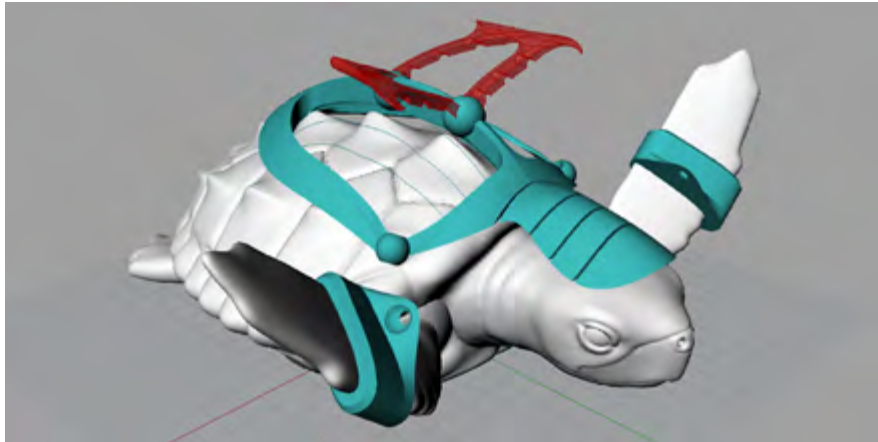
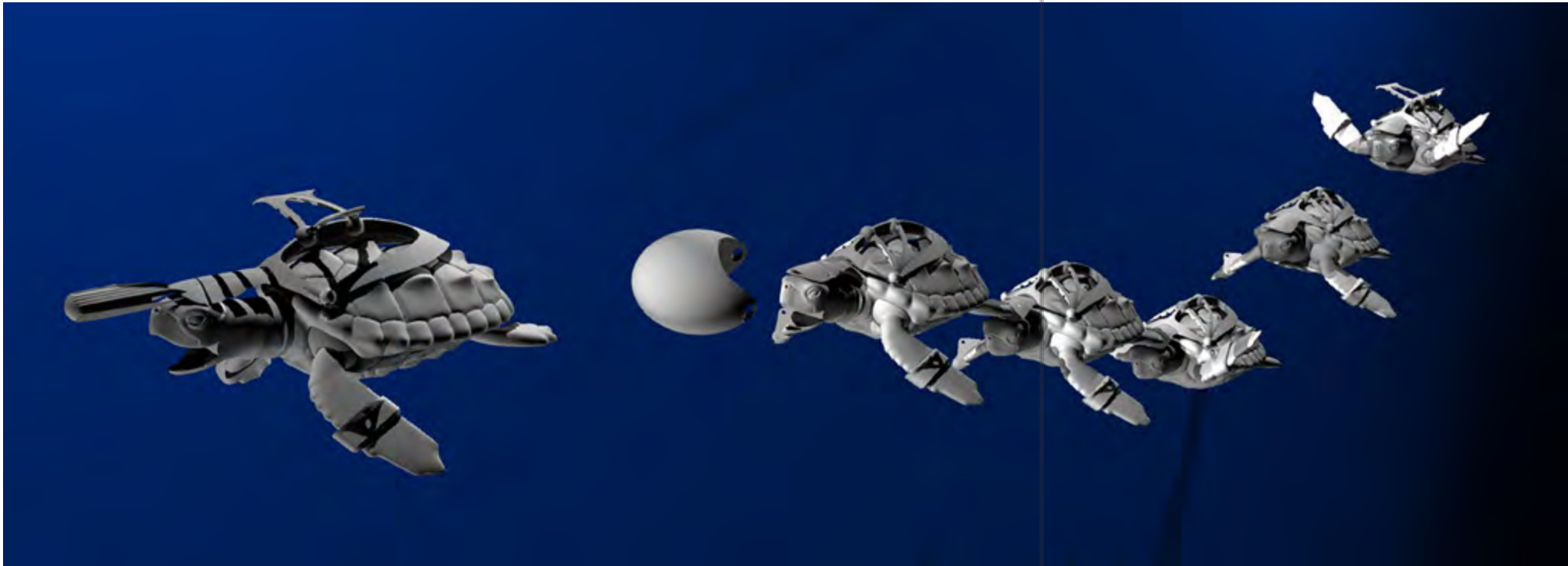

Antonio Esparza, *The TurtleBag*, 2016–2017.
The *TurtleBag* is a 3D printed exoskeleton for turtles that can distinguish plastic bags from jellyfish, in order to enable them to survive in a progressively postnatural world. The bags use a pair of one-way valves to swallow plastic bags through a small gap. The *TurtleBag* is an object that enables autonomous decisions for environmental change.



Darlene Farris-LaBar, *Ancient Mediterranean Flowers from the Soil's Edge*, 2017.
Three 3D printed items that depict endangered ancient flowers only growing on particular islands surrounded by the Mediterranean sea. It is hoped that these 3D printed works can re-inspire and make humans aware of fragile species being lost.

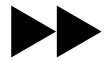

Erich Berger & Mari Keto



"Nobody remembers why it was radioactive in the first place."
As the world turns again towards nuclear power, producing readily available energy but also waste toxic for millions of years, urgent questions once again emerge: *What do we leave behind, what will the future inherit from us? How can we as individuals and society deal with the scales and scopes of deep time? How can we make sense of the vast time-scales involved?*

Inheritance consists of precious jewelry, a necklace, earring and a broché, which are radioactive and therefore, rendered practically and symbolically unwearable for deep time, until the radionuclide transmutes naturally into a stable and non-radioactive isotope of lead. Together with an electromechanical device to determine the remaining radioactivity the jewelry is stored in a concrete container which is built to endure over a vast amount of time. With these items the story goes that each time the jewelry is handed over from one generation to the next, the ritual of measurement determines if the jewelry can finally be brought in use and fulfill its promise of wealth and identity or if it has to be stored away until the next generation.



Opposite page: Portrait. Photo by Anders Bøggild.

Top: Installation view. Photo by Anders Bøggild.

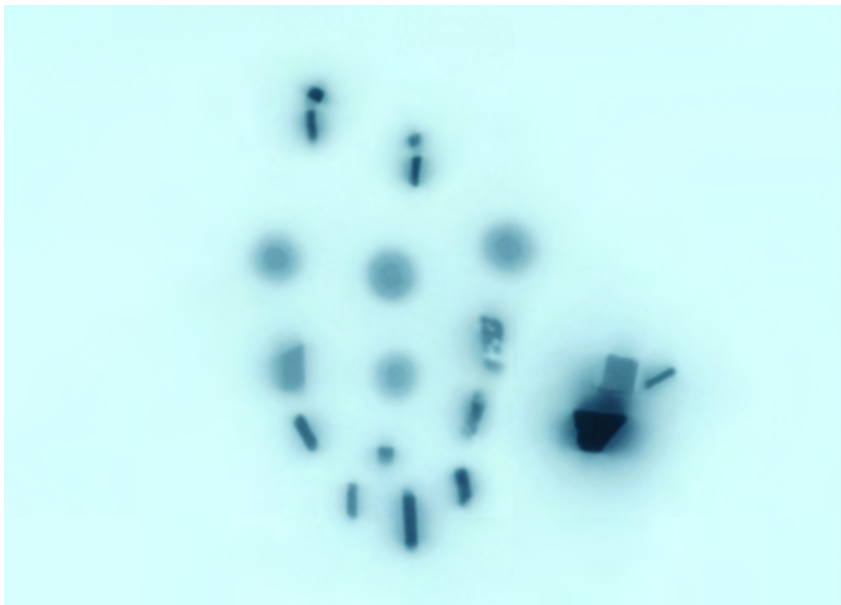

Top: Jewelry. Photo by Anders Bøggild.

Bottom: Autoradiography. Photo by Anders Bøggild.



Stack. Photos by Anders Bøggild.

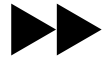

Design Earth

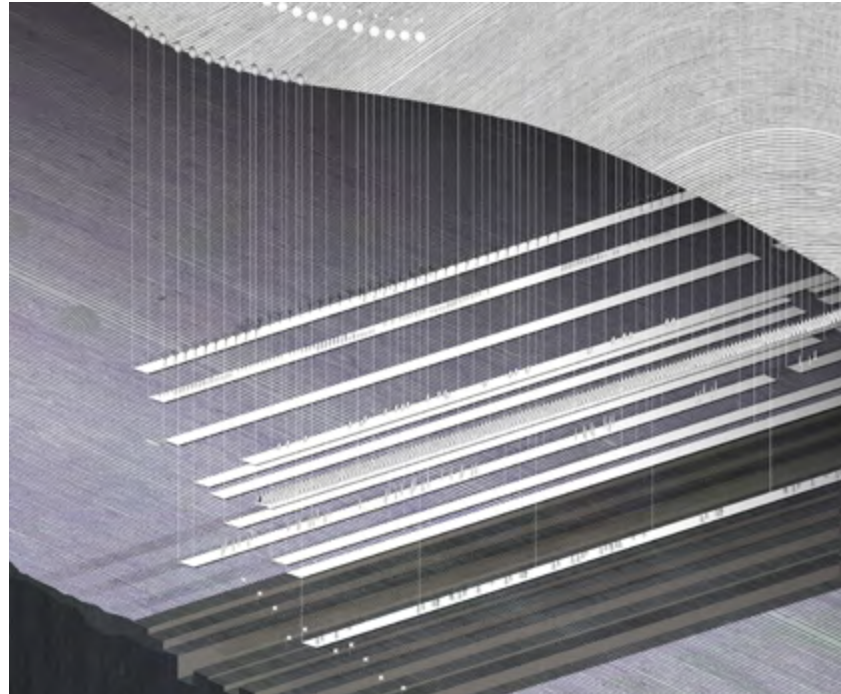

In the opening chapter of *Ocean Gardens*, an early handbook on aquarium care, the British artist and naturalist Noel Humphreys admonished his reader: “To appreciate Nature, the mind requires a special education, without which the eye and the ear perceive but little of the miracles passing before them.” He added, “the wonders of the ocean floor do not reveal themselves to vulgar eyes.”

The aquarium was born out of such desire to make sense, or represent to the senses, the inaccessible, expansive, and mysterious deep sea. Today, the call to develop “vulgar eyes” is ever timely as humans, who have declared themselves “geographic leviathans,” attempt to make sense of their transformation of the ocean – of gyres of marine debris, deep-sea mining plumes, and ocean acidification. The current environmental condition seems to involve a crisis of the imagination, of the dead-end worlds of prescriptive technocratic solutions or apocalyptic scenarios, the amendment of which might depend on finding other ways of imagining nature and humanity’s relation to it.

Geographic Leviathan explores such affective agency of a cabinet of natural history in a post-natural world. The drawings appropriate the aquarium worldview to take aim at the abysmal distance between our selfish economic worries and the great scales of the Earth. Each aquarium constructs a section of the Pacific Ocean through the Clarion-Clipperton Fracture Zone. Collectively, the nine aquariums weave together the externalities of resource exploitation and climate change into spatial scales, temporalities, and species beyond the human.

Project team:
Rania Ghosn, El Hadi Jazairy
with Reid Fellenbaum, Ya Suo,
Jia Weng, Shuya Xu, Saswati Das
and initial contributions by
Rixt Woudstra

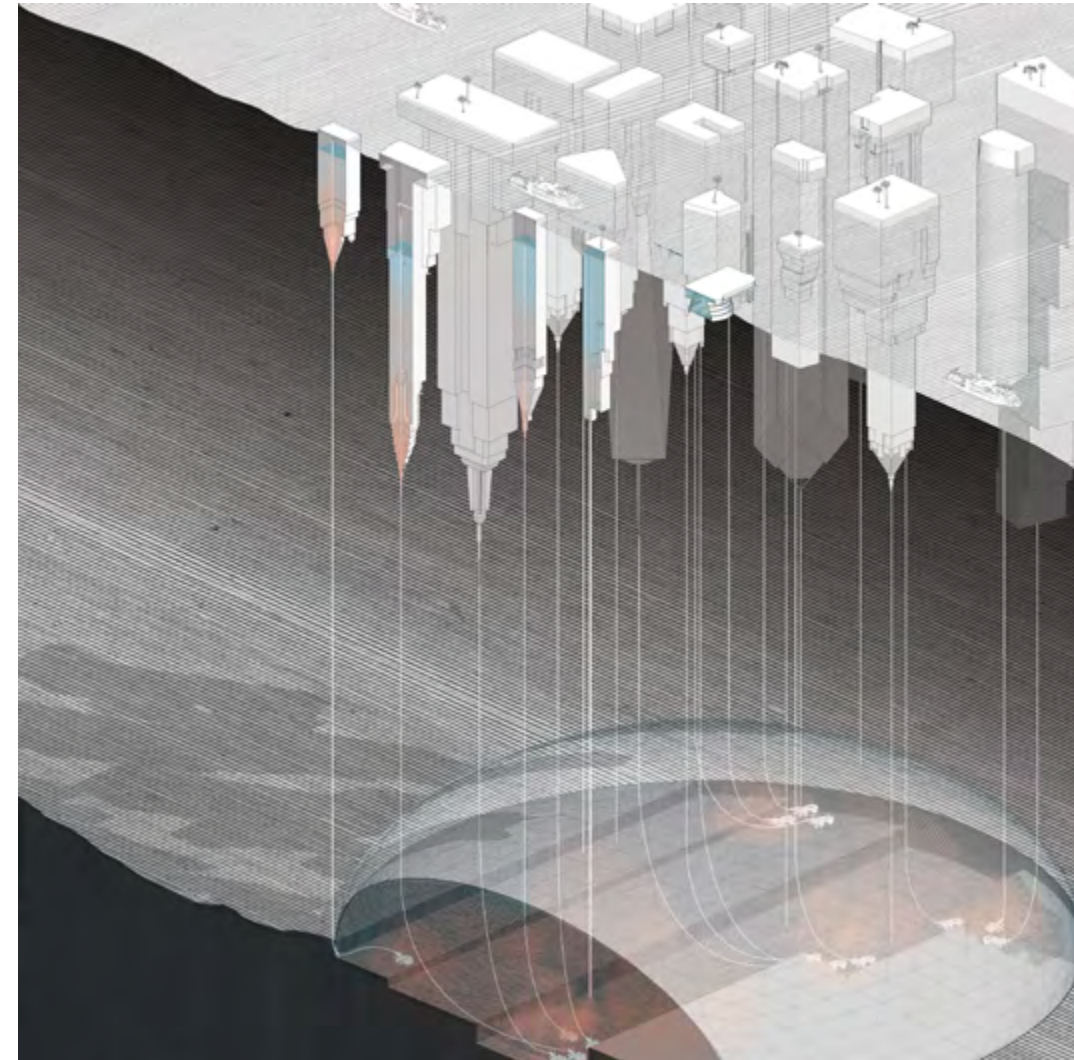

Opposite page: OVERMINING

The International Seabed Authority mandates the conservation of the flora and fauna in the mining area of the Clipperton fault. A terra-forming infrastructure relocates transects of substrate samples to a suspended ecological reserve. Over a decade, the infrastructure incubates a benthic ecosystem that will be grafted onto the depleted seabed.

Top: BELOW THE WATER TOWERS

A catchment dome caps mining activities occurring on the ocean floor to contain localized sediment plume. Polluted water is separated from surrounding water and transported into a series of inverted water towers just below the surface for processing. Purified water is gradually released back to the ocean.

MARINE LANDFILLS

Large-scale landfills capture floating waste, oil, fuel and detergents from the Pacific Gyres. Seawater cascades into a landfill to be filtered by a one-way membrane surface. When a marine landfill site is filled, the inverted pyramid is sealed and becomes a floating island in the sea.

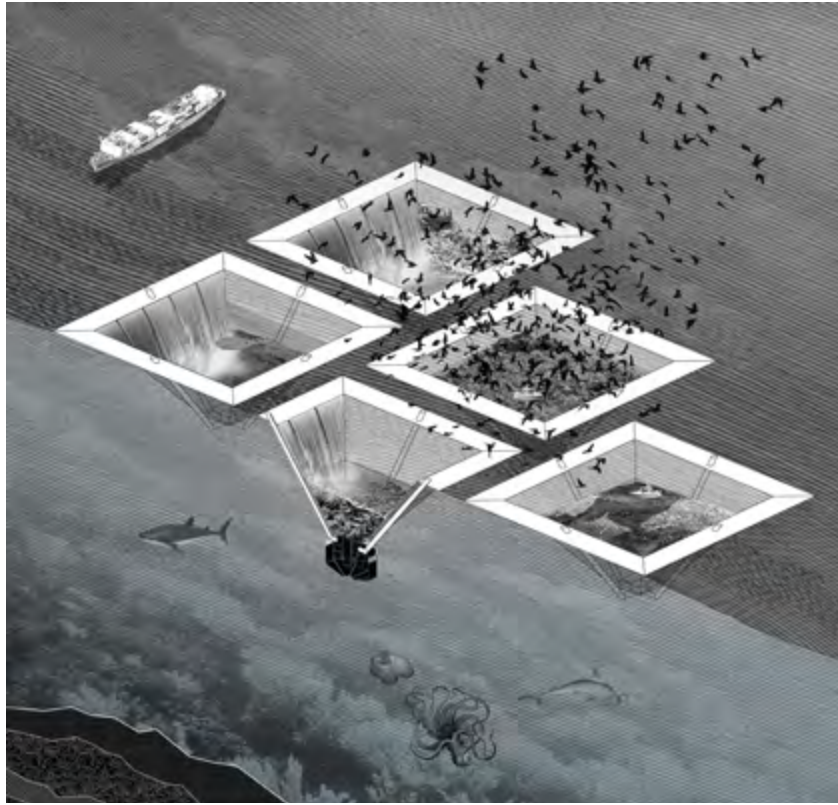

IRON TOWERS

Suggested as solution to ocean acidification, iron fertilization stimulates photosynthesis in plankton converting dissolved carbon dioxide into carbohydrates and oxygen. The vertical tensile structure, which contains high iron concentrations of water, extends the habitat of phytoplankton to the deep ocean attracting corals and other sea creatures to the structure.

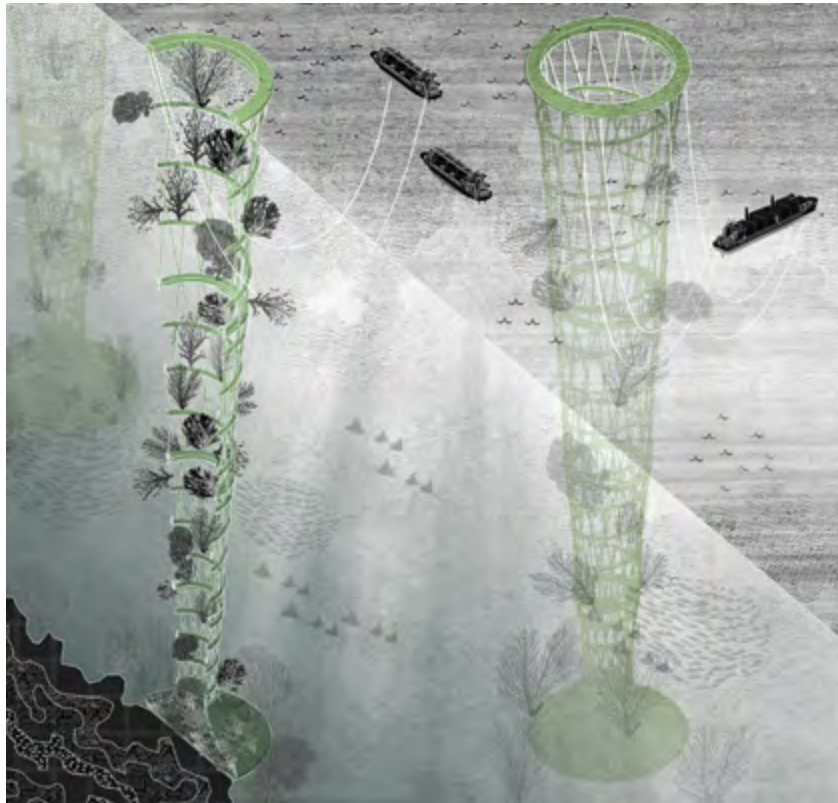

MEDUSA MAZE

Climate change opens a niche for the rapid proliferation of jellyfish. The submerged maze is a jellyfish Pac-Man, populated with planktons and sea turtles. The Pac-Medusa is a jellyfish husbandry for an emerging cosmetic industry. It is also a *Damnatio ad bestias*, an Anthropocene arena that pits the gelatinous beasts against their predators in a luminescent aquarium.

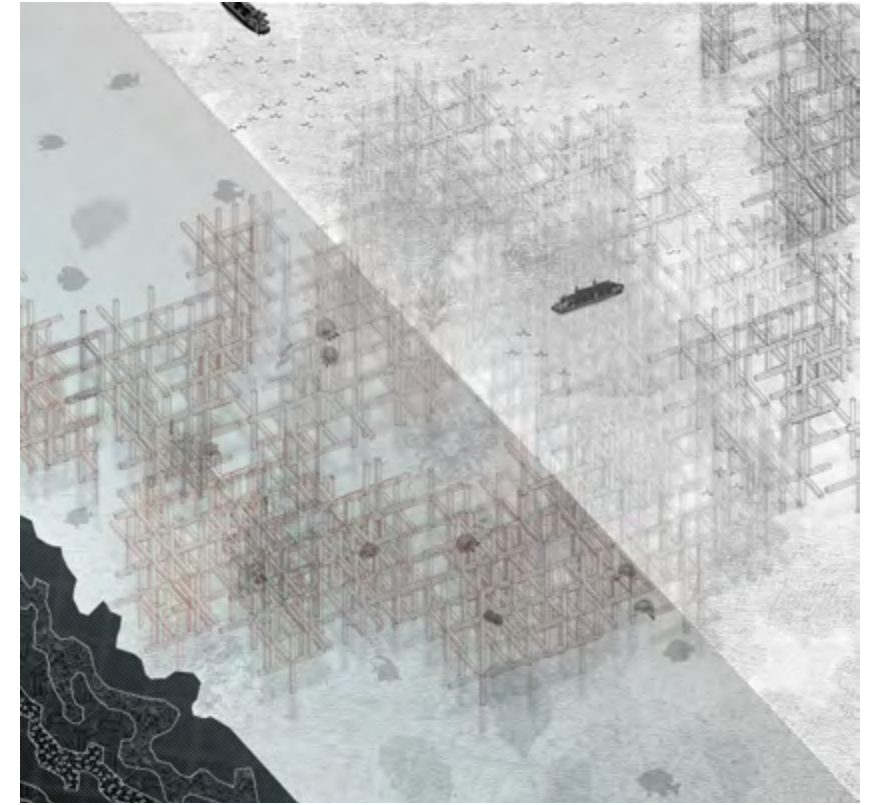

PARLIAMENT OF REFUGEES

The Parliament of Refugees is an assembly of Anthropocene things, such as sea turtles, plastic bags, CO₂ molecules, scallops, bleached corals, drowning wetlands, hammerhead sharks, algae, Homo sapiens, *Brighamia rockii*, Nihoa finch. The Assembly is organized around a hollow pillar that connects it to the center of the Earth through a submerged volcano.

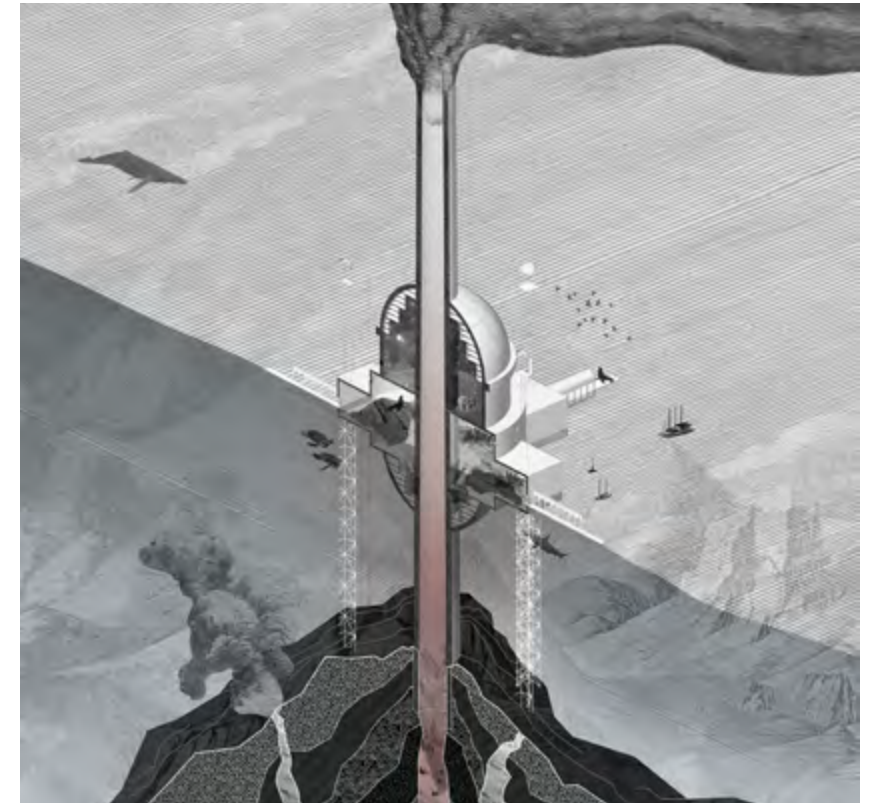

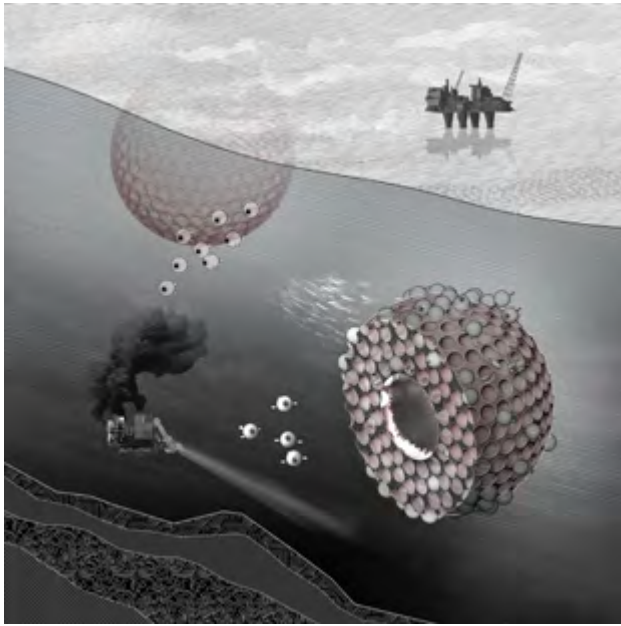

ROBOT FISH COLONY

Deep-sea mining produces plumes that smother near-bottom species away from their habitats. A school of cyborg fish restores such habitats by collecting the plumes into a massive spherical sponge-like nest where the toxic particles are solidified and processed into energy. The fish subsequently decompose into organic sustenance for the returning species.

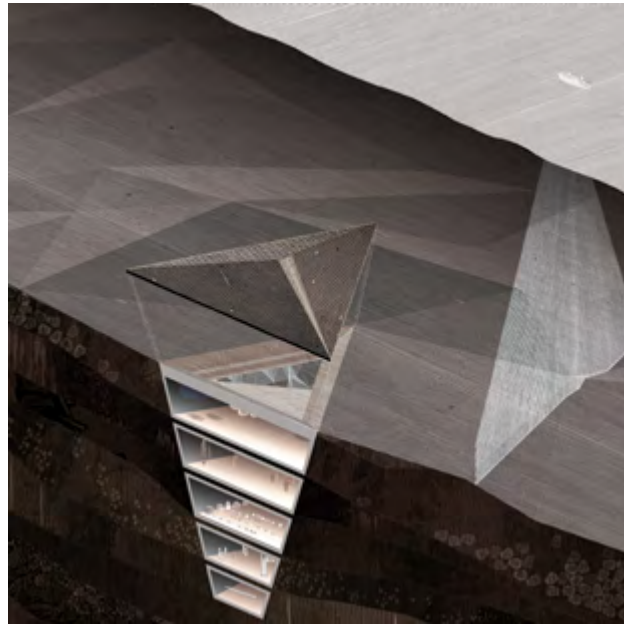

CLASSIFIED SEDIMENTS

An artificial landform camouflages the entrance to a sequence of vaults that extend deep into the Earth's crust to house security and intelligence records on the deep sea. This icon of secrecy dissimulates itself by mimicking the cartographic resolution of the trigonometric projection of the deep sea. The territory hides in the map.

CLIMATE SANCTUARIES

The submerged building tells the story of the first five submerged Pacific islands of Vanuatu, Marshalls, Fiji, Tuvalu and Kiribati through their cultural landscapes: volcanic mountains, coastlines, highlands villages, cliffs and water territories.



GEOGRAPHIC LEVIATHAN

The nine didactic projects assemble into a Geographic Leviathan that exquisitely juggles the oikos of eco-nomy and eco-logy. Leviathan is put to work to prowl the ocean in search of mineral resources. It has no equal, a creature without fear. The sea monster, which seems the very embodiment of nature's (or humanity's) ferocity, is figured also as the means to escape this state of nature. It is a machinic assemblage that remediates the very same environmental externalities it produces. The Leviathan is also the desire for a planetary sovereign that brings order to the Parliament of Refugees, giving formal order to a political contract that assembles all species displaced.

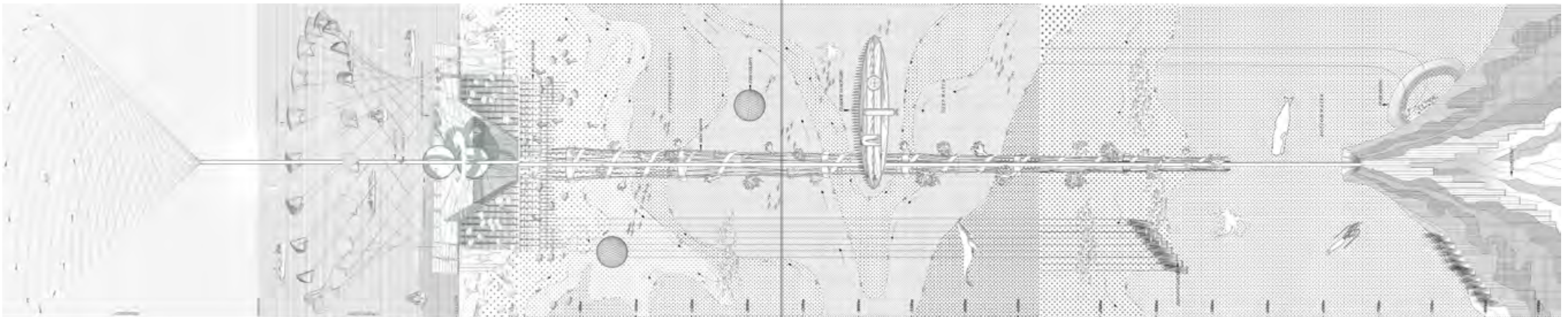



Cathryn Dwyre & Chris Perry



The elusive presence of global warming – rendered visible only at the very local effects of climate change such as in the case of coastal flooding – serves as a harbinger of *tomorrow's* world; it foreshadows a displacement of Western civilization's anthropocentric orientation in both experiential and philosophical terms. If our previous concept of 'world' was premised on the assumption that humans exist outside of 'nature,' today's understanding of *tomorrow's* 'world' renders such distinctions between human and nonhuman space transitional and thus inherently ambiguous.

Transitional Environments brings together the work of Cathryn Dwyre and Chris Perry, their interdisciplinary design practice *pneumastudio*, as well as their academic design research conducted at Pratt Institute and Rensselaer Polytechnic Institute, respectively. Viewed as a larger body of design research, the work explores the simultaneous proximity of and separation between human and nonhuman space by producing *transitional* material, formal, spatial, and programmatic conditions. Irreducible to one state or the other, these *transitional environments* are inherently 'post-natural'; rather than seek a resolution to the nature-culture conflict that characterizes our contemporary moment, they instead seek to reveal new forms of critical awareness and creative potential by embracing it.

Project team:
Cathryn Dwyre and Chris Perry (pneumastudio projects);
Cathryn Dwyre and Richard Sarrach with Gabriela Fiorentino, Yara Kavar, Dariusz Kulinski, Skye Ruoizzi (Academic research at Pratt School of Architecture);
Chris Perry with Jacob Wigton, Hailey Beyer (Academic research at Rensselaer School of Architecture)

Fig. 1.

- a. Polyconite operculée
- b. Anax imperator
- c. Portus hominum
- d. Taenia intestinalis
- e. Asplenium ceterach
- f. Lichen cinereus
- g. Vanessa virginiensis
- h. Parmelia parietina
- i. Aconitum hiemale
- j. Terra sigillata



Fig. 2.

- a. Lichen cinereus
- b. Mons et tubis
- c. Corallium rubrum
- d. Aura judicae
- e. Cladonia fimbriata
- f. Polyconite operculée
- g. Humana et animalis tubis
- h. Homo non-portus
- i. Ascidia aphrodite

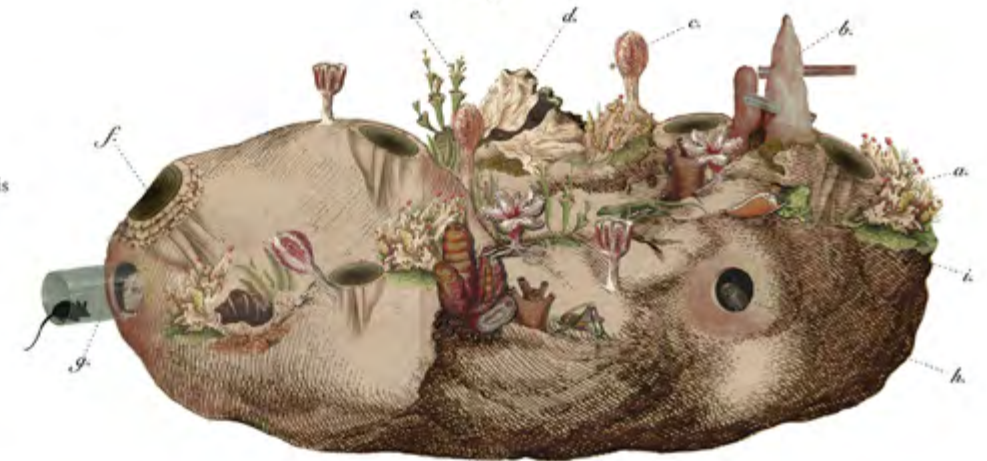

Opposite page: pneumastudio (Cathryn Dwyre and Chris Perry), *Anthropocene Folly*, 2015.

Current page: pneumastudio (Cathryn Dwyre and Chris Perry), *A Curious Cabinet*, 2017, Drawing by Cathryn Dwyre.

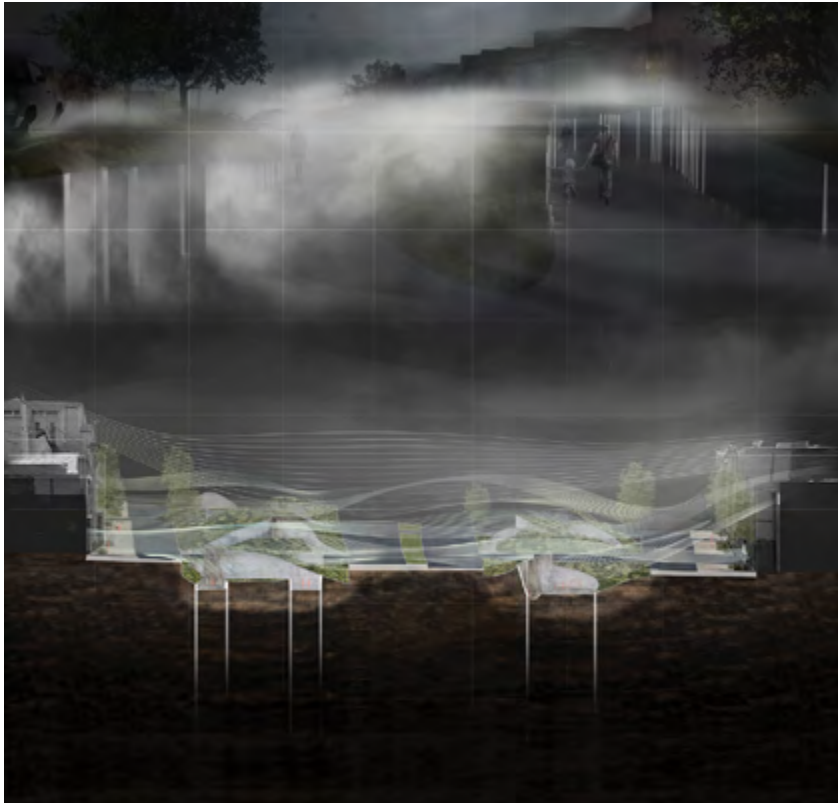
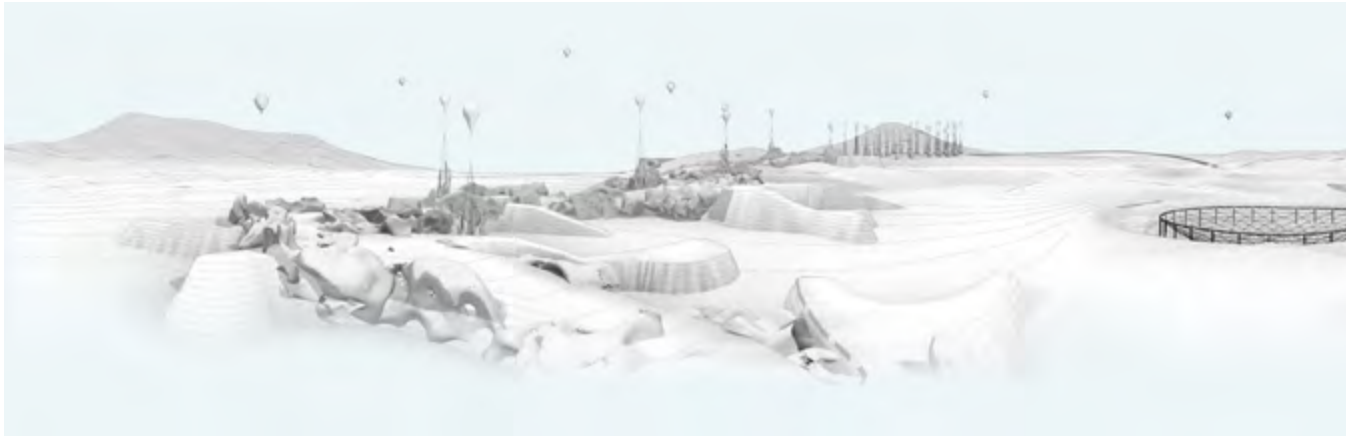

Top: Dariusz Kulinski and Skye Ruozzi (thesis students), Cathryn Dwyre and Richard Sarrach (studio critics), *Scar City*, Pratt School of Architecture, 2016.

Bottom: Gabriela Fiorentino and Yara Kawar (thesis students), Cathryn Dwyre and Richard Sarrach (studio critics), *Into the Fog*, Pratt School of Architecture, 2016.



Top: Jacob Wigton (thesis student), Chris Perry (studio critic), *Disfigured Landscapes*, Rensselaer School of Architecture, 2016.

Bottom: Hailey Beyer (thesis student), Chris Perry (studio critic), *Transgenic Environments*, Rensselaer School of Architecture, 2016.

Postnatural Architectures: Design in the Anthropocene

— Cathryn Dwyre & Chris Perry

“Frankenstein” is an ecological novel precisely not because it compels us to care for a preexisting notion of nature, but because it questions the very idea of nature. Ecological politics must constantly and ruthlessly reframe our view of the ecological: what was ‘outside’ yesterday will be ‘inside’ today. We identify with the monstrous thing. We ourselves are ‘tackily’ made of bits and pieces of stuff. The most ethical act is to love the other precisely in their artificiality, rather than seeking to prove their naturalness and authenticity.

— Timothy Morton, *Ecology Without Nature: Rethinking Environmental Aesthetics*

In its unsettling of the entrenched binaries of modernity (nature and culture; object and subject), and its provocative alienation of familiar anthropocentric scales and times, the Anthropocene opens up rather than foreclosing progressive thought. What Christophe Bonneuil calls the ‘shock of the Anthropocene’ is generating new political arguments, new modes of behaviour, new narratives, new languages and new creative forms.

— Robert Macfarlane, *Generation Anthropocene: How humans have altered the planet for ever*

Part I: The Anthropocene

The rapid technological advancements of the Industrial Revolution, beginning with the invention of the steam engine in 1784, brought with it a modern age characterized by optimistic themes of progress. Within the discipline of architecture during the first and second waves of modernism, Le Corbusier’s carefully cultivated industrial “machine aesthetic” and Alison and Peter Smithson’s prototype for a mass-produced plastic “House of the Future” personified such themes.¹

Arguably, it wasn’t until the late 1960s that concerns regarding the collateral effects of industrialization on both human and environmental health entered the mainstream. In 1970, the same year that Richard Nixon signed the National Environmental Policy Act, which resulted in the formation of the Environmental Protection Agency later that year, Robert Smithson completed *Spiral Jetty*. This rugged landform installation composed of mud, rock, and salt was sited within a “natural” setting in fact shaped by decades of industrial activity in the Great Salt Lake of Utah. Arguably the most important and influential work to emerge from the Land Art movement, this large-scale earthwork personified skepticism among a new generation of artists for the rhetoric of progress associated with industrialization.

62

¹ For more on Le Corbusier’s “machine aesthetic,” characteristic of his work prior to World War II, see Reyner Banham, “The Machine Aesthetic,” *Architectural Review* (April 1955). For more on the aesthetic of mass consumption and expendability characteristic of the postwar period, see Nigel Whitely, “Toward a Throw-Away Culture: Consumerism, Style Obsolescence, and Cultural Theory in the 1950s and 1960s,” *Oxford Art Journal* 10, no. 2, The ‘60s (1987).

We might understand our contemporary moment as having certain parallels with this period, given the extent to which art and design have begun to engage the increasingly alarming ecological crisis of global warming in philosophical and aesthetic, as well as practical, terms.² Defined by environmental theorist Timothy Morton as a “hyperobject,” given that it is “massively distributed in time and space relative to humans,”³ global warming, while impossible to represent in its totality, has unmistakable material effects at local scales. Whether in the form of coastal flooding, regional drought, or glacial retreat, it is the increasingly visible, albeit incremental, material manifestation of global warming that induces active reflection about a world in transition. If human society’s previous conception of the world was premised on the assumption that humans exist outside of nature, then this assumption no longer seems tenable. Indeed, while it was the ambition of the Industrial Revolution to insulate humans from the often unpredictable and destructive forces of nature, it was the gradual impact of industrialization on the environment that has inadvertently reaffirmed our inescapable intimacy with nature, and in ways far more threatening than ever before. As a result, we find ourselves in the Anthropocene Age, or what Morton calls the “Asymmetric Phase,” whereby humans have finally altered the planet’s complex global ecology through centuries of technological intervention and as a result, “nonhumans have finally infiltrated human social, psychic and philosophical space,”⁴ compelling a dramatic philosophical realignment as it regards previously held concepts of nature. Rather, and as cultural theorist Steven Shaviro argues, the increasing threat of ecological catastrophe that characterizes the Anthropocene brings with it a seemingly obvious admission: “the fate of humanity is deeply intertwined with the fates of all sorts of other entities” and given “how closely related we are to all the other living things on this planet, we cannot continue to consider ourselves unique.”⁵ This mode of thought displaces the centrality of the human subject with an understanding of the world as a system of nonhierarchical, interrelated things in which no one thing is privileged over another. In other words, in this world, humans can no longer be viewed as central or unique to and thus *apart from* nonhumans, but rather, always and already a *part of* them.

Thus, one might ask: In an age where humans have been fundamentally displaced from their presumed place of privilege, philosophically as well as experientially, should architecture consider displacing itself as well, as a means of establishing new affiliations beyond the human, and by implication, beyond the constraints of anthropocentrism?

Part II: Postnatural Architectures

What we identify as new forms of *postnatural architecture*, as evidenced in work by contemporary design practices like *formlessfinder*, *New-Territories*, and *pneumastudio*, among others, seeks to establish such affiliations through an exploration of the simultaneous proximity of and separation between human and nonhuman space, and by extension, architecture and environment, by producing material, formal, spatial, and programmatic qualities

² Anthony Vidler suggests that questions related to ecology and environment initiated by McHale and Banham have only recently resurfaced in architecture discourse. See Anthony Vidler, “What Happened to Ecology? John McHale and the Bucky Fuller Revival,” *Architectural Design* 80 (2010): 24–33.

³ *Ibid.*

⁴ *Ibid.*, 133.

⁵ Steven Shaviro, *The Universe of Things: On Speculative Realism* (Minneapolis: University of Minnesota, 2014), 1.

63

and conditions situated between the two and thus inherently ambiguous. Irreducible to either the artificial or the natural in this way, *postnatural architecture* seeks instead to displace such distinctions by producing a built environment imbued with qualities and conditions more akin to what architectural theorist David Gissen calls “postnaturalism,” whereby a work of architecture engages the “disciplinary tensions that produce concepts of nature and architecture simultaneously.”⁶ In this way, postnatural architecture resists a resolution to what Gissen calls the “historical crisis” of nature-culture distinctions, such that the inherent tension and conflict between the two is neither ignored nor resolved, but rather, revealed and acknowledged. For Morton, such ambiguity produces qualities and conditions of ambience or uncanniness in which artificial and natural phenomena previously thought to be separate and distinct from one another “fold and redouble and entangle and cross over themselves,”⁷ producing neither total integration nor total separation, but rather a suspended and thus unresolved state somewhere in-between. Architectural theorist Christopher Hight refers to such ambiguity as a “framework of mediation and assemblage” in which conventional oppositions such as “Nature vs. Society, or Science vs. Culture, determinism vs. autonomy” are displaced.⁸ And it is precisely this condition of displacement characteristic of an architecture of “postnaturalism” that one could argue characterizes the Anthropocene itself, whereby nature and culture have engaged in processes of mutual displacement.

In some cases, the aforementioned qualities and conditions of ambiguity are achieved principally at a programmatic scale through the proximity of human and nonhuman use. If the history of architecture, at least until the present moment, has been concerned principally, if not exclusively, with the design of buildings and environments by and for humans, the incorporation of nonhuman programming into contemporary works of architecture necessarily challenges such architectural anthropocentrism. By introducing nonhuman forms of use into the traditional space of human inhabitation, such as the provision of occupation opportunities for plant life, animal and insect life, and even weather, buildings evolve into sites for human-non-human co-habitation. In other cases, the aforementioned qualities and conditions of ambiguity are engendered principally at material, formal, and spatial scales by producing aesthetic effects that blur conventional distinctions between natural form and artificial form. As architectural theorist David Salomon notes, this conception of aesthetics, whereby “physical sensations and intellectual reflection are reconciled via our imagination,” refers to philosopher Jacques Rancière’s definition of aesthetics as “an inclusive and expansive logic” through which we make sense of the world.⁹ As such, aesthetics take on a performative value as a form of visual communication, whereby new ideas and concepts are generated through the analysis of sensation. For example, landscape historians Elizabeth Meyer and Jennifer Peeples each explore the aesthetics of toxicity as a means of producing new concepts about landscape and our relationship to it.¹⁰ In the case of Peeples, it is photographer Edward Burtynsky’s work which demonstrates

the capacity of art to communicate “the horror of the toxic sublime,” which in turn “calls to question the personal, social and environmental ethics that allows these places of contamination to exist.”¹¹ And as Peeples goes on to argue, far from leaving the viewer suspended in a state of paralysis, the “compositional choices” made by Burtynsky produce “images fraught with tensions that require thought and contemplation,” which in turn “provide the impetus necessary for attitudinal change.”¹² This is achieved in part by producing simultaneous conditions of beauty and disgust, a dissonant and thus ambiguous condition that promotes active reflection similar to Immanuel Kant’s concept of “negative pleasure,” whereby the viewer is at once repelled and attracted, arguably an experience of aesthetic and philosophical displacement not unlike that of the postnatural condition itself.¹³

As one example of postnatural architecture, *formlessfinder* provides a deceptively simple description of these and other forms of programmatic and aesthetic ambiguity when they state the following: “We embrace the raw, the unprocessed, the unstable, the ephemeral, and the degradable... Our spaces are challenging, lacking clear boundaries or legible hierarchies, and so fundamentally demand interaction and engagement.”¹⁴ This statement, provocative as it might be as a means of describing a different kind of architecture, also serves as an apt, albeit unsettling, description of a different kind of world, that which has been fundamentally altered by the haunting effects of global warming. Indeed, the qualities of displacement associated with the Anthropocene are also endemic to their chosen term “formless,” borrowed from Georges Bataille’s “informe” to describe qualities of “slippage” between form and content in a work of art, which in turn serves to destabilize meaning itself.¹⁵ In the exhibition *The Formless: Instructions for Use*, co-curated by Yve-Alain Bois and Rosalind Krauss for the Centre Pompidou in 1996, Bataille’s concept of “informe” or “formless” is deployed as a means of rethinking received notions of modernism, specifically as inherited by the formal classifications of Clement Greenberg, with Robert Smithson’s *Asphalt Rundown* serving as an exemplar of formlessness and the exhibition’s first featured work. As such, Smithson’s work challenges not only the formal disciplinary barriers between art and landscape, but the physical as well as philosophical barriers between nature and culture. Similarly, *formlessfinder* challenges received definitions of architectural form and by extension formal definitions of architecture itself, to the extent that the history of architectural form is principally a history of formalizing the identity of architecture as distinct from other identities, including the surrounding landscape. Thus, as one would expect, projects like *Load Test* deploy formal and material strategies that serve to undermine such distinctions.

With the *Anthropocene Folly* proposal, *pneumastudio*, which brings together the disciplines of landscape architecture and architecture, explores similar ambiguities by revisiting questions of use and meaning particular to the history of the architectural folly.¹⁶ Designed for OMI International Arts Center in Ghent, New York, and situated within their sculpture grounds,

⁶ David Gissen, “Nature’s Historical Crises,” *Journal of Architectural Education* 69, no. 1 (March 2015): 5.

⁷ Timothy Morton, *Ecology Without Nature: Rethinking Environmental Aesthetics* (Cambridge MA: Harvard, 2007), 178.

⁸ Christopher Hight, “Designing Ecologies,” in *Projective Ecologies*, eds. Chris Reed and Nina-Marie Lister (New York: Actar, 2014), 93.

⁹ David Salomon, “Towards a New Infrastructure: Aesthetic Thinking, Synthetic Sensibilities,” *Journal of Landscape Architecture* 11, no. 2 (Spring 2016): 55.

¹⁰ For more on “toxic beauty,” see Elizabeth K. Meyer, “Sustaining Beauty: The Performance of Appearance, A Manifesto in Three Parts,” *Journal of Landscape Architecture* 3, no. 1 (Spring 2008): 6–23. For more on the “toxic sublime,” see Jennifer Peeples, “Toxic Sublime: Imaging Contaminated Landscapes,” *Environmental Communication: A Journal of Nature and Culture* 5, no. 4 (December 2011): 373–392.

¹¹ Jennifer Peeples, “Toxic Sublime: Imaging Contaminated Landscapes,” *Environmental Communication: A Journal of Nature and Culture* 5, no. 4 (December 2011): 380.

¹² *Ibid.*

¹³ *Ibid.*

¹⁴ Excerpts from *formlessfinder*’s pedagogical statement: <http://www.formlessfinder.com/statement>.

¹⁵ Yve-Alain Bois and Rosalind E. Krauss, *Formless: A User’s Guide* (New York: Zone Books, 1997), 15.

¹⁶ For more on the architectural folly as “useless architecture,” see Bernard Tschumi, “Broadway Follies,” in *Follies: Architecture for the Late-Twentieth-Century Landscape*, eds. B.J. Archer and Anthony Vidler (New York: Rizzoli, 1983), 42.

¹⁷ For more on the concept of “subnature,” see David Gissen, *Subnature: Architecture’s Other Environments* (New York: Princeton Architectural Press, 2009).

¹⁸ Timothy Morton, “Architecture without Nature,” in *Tarp Architecture Manual: Not Nature*, eds. Sarah Ruel-Bergerton and Hannibal Newsom (New York: Pratt Institute School of Architecture, 2012), 20–25.

¹⁹ David Gissen, “Introduction: Architecture Beyond Environment,” *Architectural Design (AD), Territory: Architecture Beyond Environment* (Wiley-Academy, 2010): 13.

²⁰ *Ibid.*, 8–13.

humans are allowed access to this folly but in a way that is intentionally uncomfortable, claustrophobic, and displaced from any point of assumed privilege. Taking the form of a series of crevice-like spaces, the folly’s interior forces the human body to bend, duck, and slither, suggesting to human occupants that these spaces, while physically accessible, were not necessarily designed for them. Furthermore, the materiality and atmosphere of the folly’s interior confronts the occupant with a quality of nature that is typically kept at a more comfortable distance, a quality akin to Gissen’s concept of “subnature.”¹⁷ As such, the folly’s interior produces material and atmospheric qualities characterized by dampness and lack of daylight; a dark, musty *underground* environment conducive to the proliferation of moss, slugs, and spider webs. All the while, the more familiar forms of nature—the plants, trees, butterflies, and birds inhabiting the top of the folly—are intentionally lifted away from the human and thus remain physically, and to some extent, visually inaccessible. In this way, the human’s conventional orientation to nature can be understood as displaced: No longer safely above ground, the human moves into and, in effect, *underground*, thus occupying a simultaneous interior/exterior condition, philosophically as well as experientially, whereby human–nonhuman distinctions are rendered ambiguous.

In a similar way, *Dusty Relief* by New-Territories, a speculative proposal that, while serving to remove toxins from the air through an electromagnetic building envelope, simultaneously reimagines the aesthetics of architecture as well as environment, challenges conventional distinctions between function and aesthetic, nature and culture, architecture and environment by rendering such distinctions entirely ambiguous. As Morton notes, *Dusty Relief* exemplifies architectural design “in a dark ecological way, admitting our coexistence with toxic substances we have created and exploited.”¹⁸

Hence, *postnatural architecture* is conceived neither as an autonomous cultural object nor an instrumentalized extension of its external environment, the subject of which has made for a polarizing debate within the discipline since at least the 1960s, but rather, what Gissen calls architecture as “material and theoretical ‘genesis device’ – a machine that makes environments but also ideas about nature and environments.”¹⁹ In this way, architecture mediates a recalcitrant divide within the discipline between those who conceive architecture as an extension of its broader social, technological, and natural environment, what Gissen terms an “environment-architecture,”²⁰ and those who define architecture as an autonomous or solipsistic practice concerned principally, if not exclusively, with an internalized discourse of abstract concepts and aesthetics indifferent to the outside world. Resisting such dichotomies, *postnatural architecture* works at instrumental and discursive levels simultaneously; it engages problems and challenges facing architecture and the environment while simultaneously producing new concepts about architecture and the environment.

SHELLS & CO-HABITATS

68

Shells, cells, shelters, habitats, and buildings. Words whose meaning changes according to new conditions and needs. The home becomes 'smart' thanks to infrastructures and systems that capture and study the habits of its users; former bunkers are used to house the data centers of the connected worlds; controlled ecosystems are used to save and maintain disappearing plants. *What do these concurrent developments mean for the future of the urban and the natural environment?*

The exhibition examines several types of shells addressing, respectively, the human, nature, and information. Different proposals take into consideration the increasing role of technology as well as the possibilities and needs of different geophysical environments and topographies. Scenarios include references to spaces of continuous mediation and surveillance, units of future network infrastructures, techno-natural shelters as well as proposals for exoskeletons made for animals. The features of tomorrow's possible shells and places are highlighted while looking into the potential of new ways of co-existence between human and non-human elements.



Aristide Antonas, *Cave for an Unknown Traveler*, 2014–ongoing.



APNTANIAN
13

ΕΙΣΑΓ
THE
REDS

ΓΚΥ2Η
13

ARUKI

Zissis Kotionis, Hot_Camp: A Trans Urban block, 2017.





Liam Young, *Tomorrow's Storeys*, 2017.

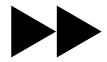

Aristide Antonas

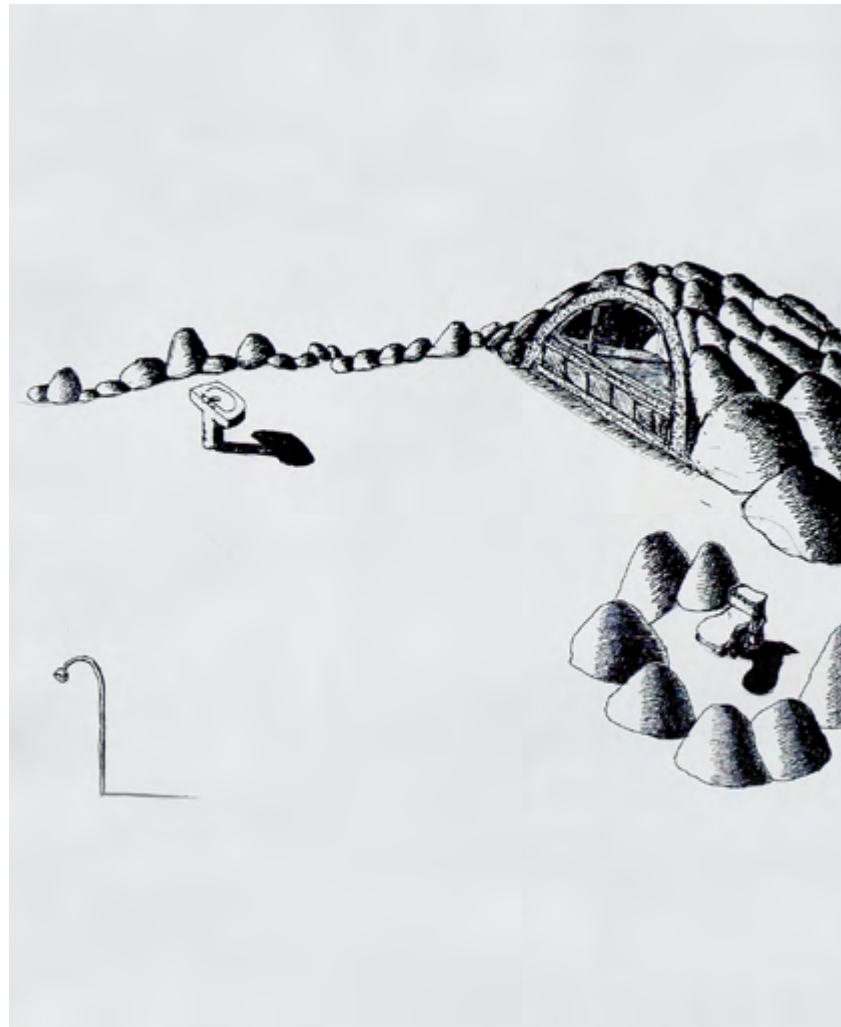

The *Cave for an Unknown Traveler* is an installation composed as a scenario for a ‘fake archaic cave,’ which is nevertheless equipped with the infra-structural luxury of a modern hotel room. It is organized with a tartan floor in the color of the ground, an open-air sink, toilet and shower, a diligently hidden infrastructure, an elementary space for storage, and a simple bed lying under a concrete vault. The setting brings some of the accessories of a hotel room to the natural environment of a deserted island. A system of such distant caves creates a complex equivalent to a ‘natural hotel.’ The natural hotel is completed with a system of invisible services. There are plenty of them, yet all meticulously veiled. The *Cave for an Unknown Traveler* gives the possibility of a supposedly isolated stay in a deserted island, while this is only supported as a scenographic condition.

Project team:
Aristide Antonas with
Katerina Grigoropoulou,
Katerina Koutsogianni,
Yannikos Vassiloulis

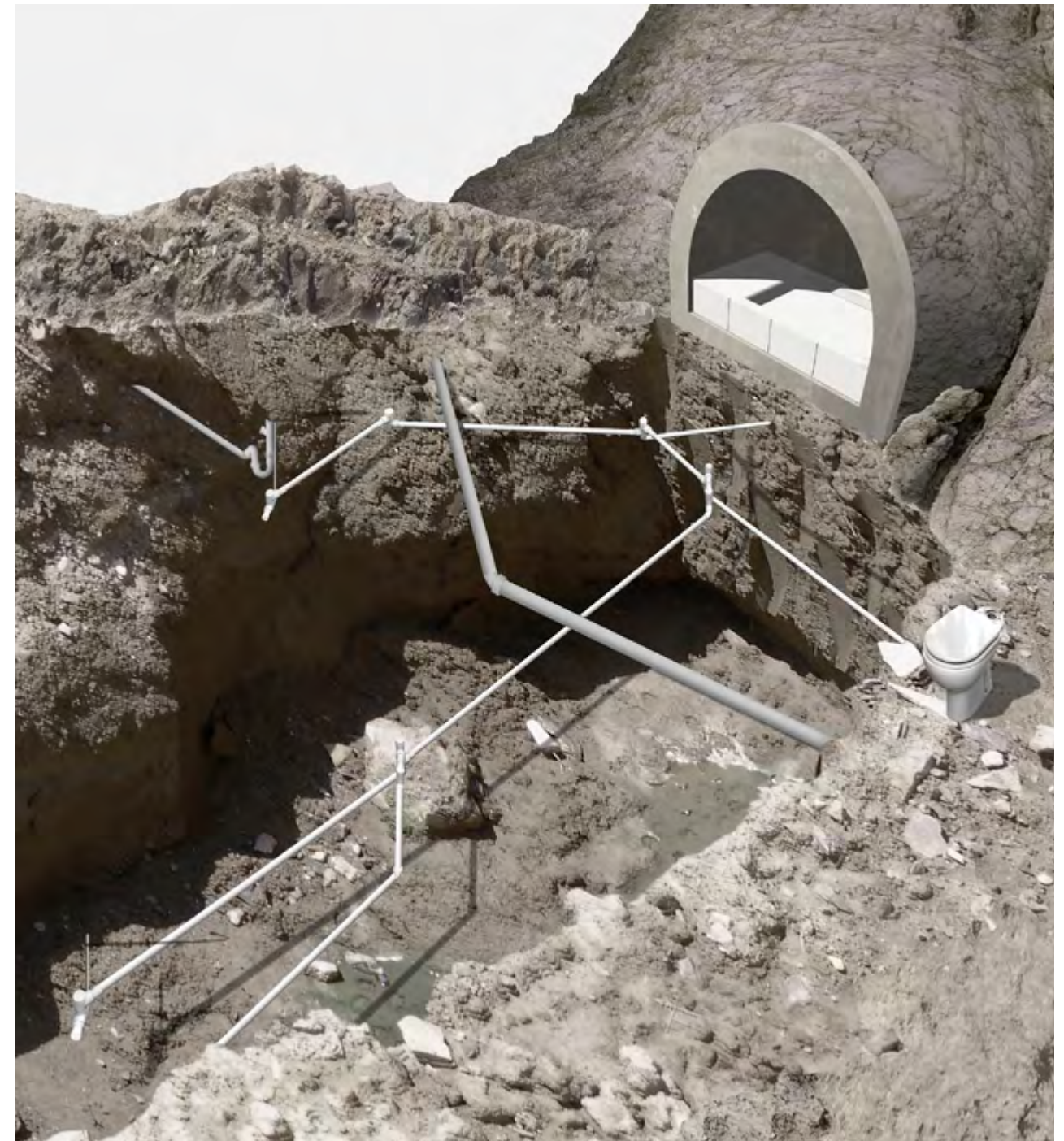

Opposite page: Disposition of inhabited desert.
Above: Infrastructure buried to be invisible.

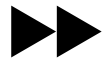

**Hot_Camp:
A Trans Urban block**

2017

Zissis Kotionis

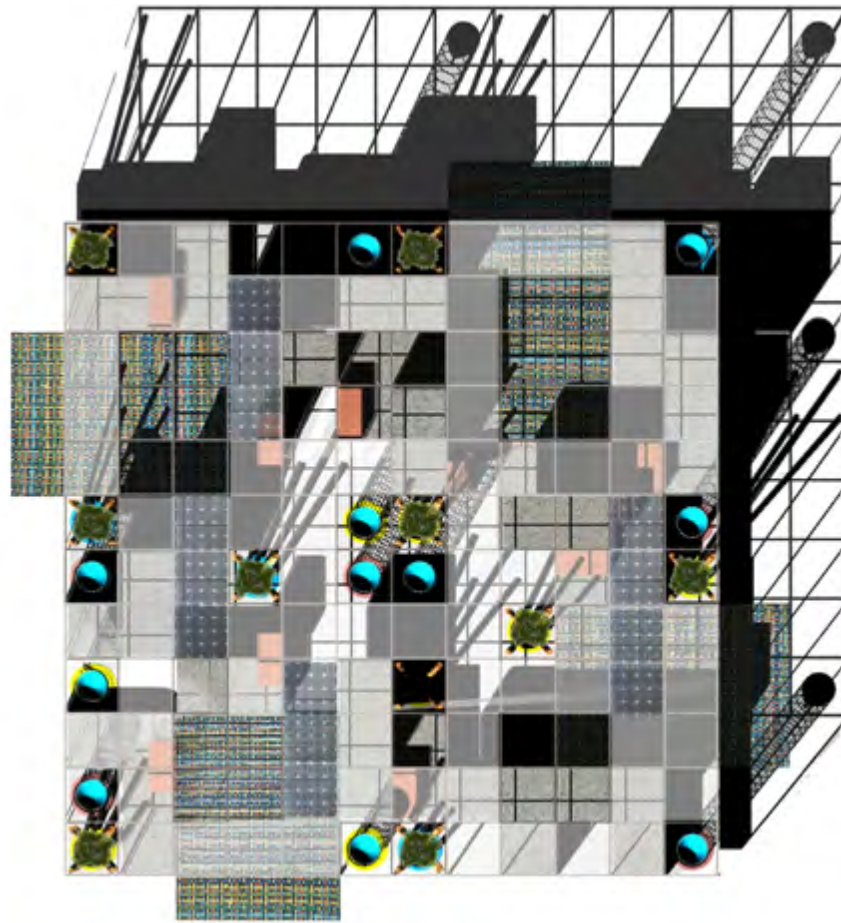

A Hothouse is a techno-natural apparatus providing a controlled, warm environment for cultivating plants. On the other hand, a Concentration Camp is a gated settlement for people excepted from law protection, usually under the condition of obligatory labour. Connecting the two terms and programs in a hybrid one, *Hot_Camp* is introduced as an apparatus for collective living and working in the margins or in-between cities. It intends to provide a spatial and performative condition under which metropolitan life melts into rural life and vice versa. Life for moving people in a state of emergency is challenged to form an open community. The assemblage of people with controversial identities reflects in an architectural assemblage of various living spaces, objects and organic apparatuses. All these form an alternative urban block, generic, awaiting to be grounded anywhere, as a colony between the city and the land. This trans-urban block refers to the precarious conditions of tomorrow's life, in relevance to the South, under the Mediterranean climatic, anthropological and political horizon.

Project team:
Zissis Kotionis with
Efthymia Dimitrakopoulou





Zenovia Toloudi /
Studio Z

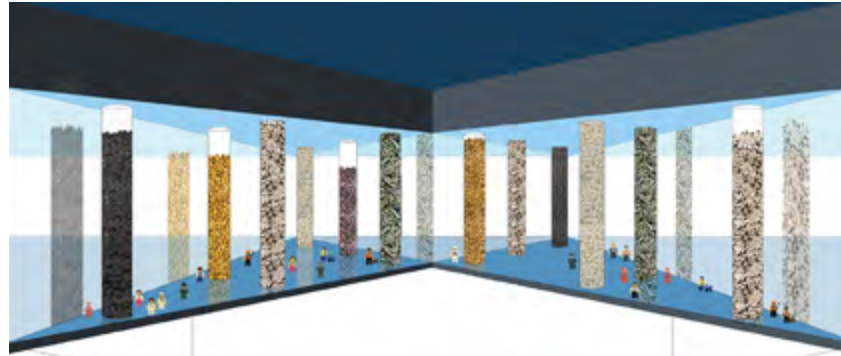

16.05.2017, 20:20
 ...spearmint, fennel, thyme, oregano – check
 ...grapes, peaches, cherries, melons – check
 ...olives, sesame, figs – check
 ...wheat, barley, almonds, walnuts – check

collecting, sorting, drying, depositing, freezing,
 sealing, exchanging – transactions completed

16.05.2017, 20:20
 The spectator stoops slowly, inserts
 themselves in the inspection hole, observes
 the silos-displays, surveils the activities
 of community workers, experiences
 the architecture, is being lost in space.

Silo(e)scapes envisions a hybrid of a seed bank, a sharing economy and a museum for Mediterranean plant species that may disappear. In *Silo(e)scapes* techno-utopia, the threatened native seeds are stored in transparent silos/museum displays which are also the columns of a communal architecture. *Silo(e)scapes* provides to community workers the preservation of local seeds biodiversity and the protection of Mediterranean tastes, flavors, nutrients, and medicinal capacities threatened by environmental catastrophes as well as the increasing demand for control and standardization. *Silo(e)scapes* does not belong to private corporations. The members of *Silo(e)scapes* share the contents of the deposits. Autarky is a priority. And so is freedom and security.

Is the future of Mediterranean food a ruined landscape? *Silo(e)scapes* art installation transforms the anxiety of such dystopia into the experience of a futuristic architecture. In *Silo(e)scapes* spectators surveil a doll-house metaphor of a futuristic microcosmos through a panopticon structure that expands in infinity. *Silo(e)scapes* functions as a wearable room, a portal between reality and fantasy: Spectators insert their head into a hole to observe the threatened species, the seed bank museum, and the sharing economy of Lilliputian citizens. The seed-columns of the infinite space, the kaleidoscope of mirrors and agrarian sounds construct a perceptible space, which is neither real, nor a replica; it is rather artificial and illusive. *Silo(e)scapes* is both threatening and seductive. The theatrical and voyeuristic experience of *Silo(e)scapes* forms an apparatus that awakens memories, but also empowers spectators to disrupt the sequence of events causing the disappearance of these species.

Project team:
 Zenovia Toloudi with
 George Toloudis &
 Panagiotis Stamboulidis Shop

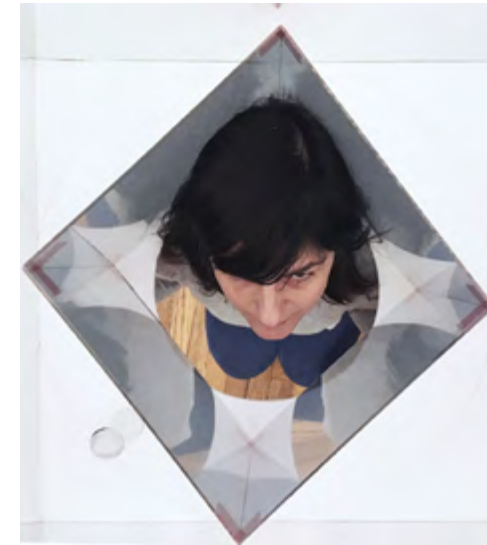

Opposite page: Detail drawing.
 Current page top: Prototype.
 Bottom: Installation drawing.



Installation detail. Photo by Mariana Bisti.



Right top: Silos Detail (Thrace).
Photo by Maria Toloudi.

Center & bottom: Mediterranean Seeds (Thrace).
Photo by Maria Toloudi.

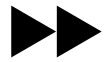

Emma Charles



White Mountain is a 16mm docu-fiction film set primarily in the Pionen data center, which is located 30 meters under the granite rocks of Vita Bergen Park in Stockholm. The site used to be a former Cold War-era civil defense bunker and was redesigned in 2008 by architect Albert France-Lanord as a data center to house servers for clients – among which were also WikiLeaks and the Pirate Bay. Starting by surveying the rough topography of the surrounding Södermalm landscape, the film gradually pushes beneath the surface and illuminates the ordinarily concealed network infrastructure. As the camera idles on the florescent-lit server stacks, issues of privacy, surveillance and digital sovereignty inevitably emanate. The hydrogen bomb proof subterranean hub has been, interestingly, constructed with direct references to science fiction films such as *Silent Running*, and the classic Ken Adam's set design. Playing on the sci-fi aesthetic and with a poetic narration written by Jussi Parikka, *White Mountain* uncovers the varying forms of temporality captured in data space and geology. Gathering vibrational and electromagnetic sound from the rock above as well as from deep inside the server room itself, the work reveals and processes the reverberations of the hidden environment.



Video stills.





Liam Young



In *Tomorrow's Storeys* we drift from room to room, eavesdropping in on the overheard conversations of the occupants of a near future Athenian apartment block. Beginning two months prior to the opening of the *Tomorrows* exhibition architect Liam Young organized a public think tank consisting of a group of science fiction authors, visual artists, directors, photographers and architects, aiming to produce a series of critical fictions about the future of Athens. Through discussions, illustrations and speculations, the working group authored a series of short stories set within the walls of a single imaginary apartment block, collectively constructing narratives of the future life of Athenian citizens. Evolved from the traditional form of the *Polykatoikia*, the building they designed is a continuous urban mass where each Athenian is not given a minimum basic income but rather a minimum basic floor area, a percentage of the volume of a building but not a fixed location. The block is a portrayal of a new form of urban organization where a building is reformatted like a Facebook page and a diverse group of occupants are collapsed together in radical juxtapositions as they roam across the floors, following functions that are shifting by the hour. This is just one temporary moment in a block of endless configurations, a window into a speculative building, the city that surrounds it and the lives it contains.

Project team:
Liam Young with Leigh Alexander, Ioanna Bourazopoulou, James Bridle, Panos Dragonas, Marina Gioti and Bruce Sterling (texts); Alexey Marfin (VFX Supervisor); Paul Krist, Aman Sheth, Sara Segura, Kiran Nayak (animation team); Coti K. (soundtrack); Matthias Fritsch (technical support)

Video stills.



Video stills.

The Suspended City

— Bruce Sterling

Bald and bearded, Alekos was a bureaucrat on his pension, a flaneur, a man of the world. Panos, younger and sharper-dressed, would soon become a certified emergency medical technician.

These two men were relatives, and therefore two roommates in a complex and fluid Athenian dwelling arrangement. Their city had suffered a power failure and the urban software was down. Their apartment was temporarily uninhabitable. Being of an adventurous bent, they both fetched flashlights on a private quest for public trouble.

Events like this happened. All attempts to subject a great city to algorithms were eventually self-defeating. The conceptual soil of Greece was inherently unstable. Life was like that.

"Maybe you'll return to Athens," said Alekos kindly, "after your tour of duty in those less happy, more agitated areas."

"There can never be a shortage of trouble in this world," said Panos, "so I'm confident about my long-term employment."

A small crowd of Athenian locals shuffled by them in the blacked-out street, some of them bearing lit candles. Despite their city's near-complete infrastructural collapse, the citizens had luminous, self-aware expressions, like well-chosen extras for some cinematic remake of Euripides.

The flickering waxy lights made their faces masklike and poetic: Sudden recognition. Subdued fear. Distant emptiness. Veiled shame. All the children were having a sudden holiday from public order, so they were simply and childishly overjoyed.

Such self-possessed calm in a comprehensive public disaster plunged Alekos into a moralizing rant. "What's become of the wild Athenian crowds that I saw at your age?" he socratically demanded. "Those tattooed anarchist rioters, those furtive drug dealers, those skulking refugee illegals? All the cops of Athens lived in riot gear. There was crazily radical street art graffiti on every available surface."

"Some German tourists will show up for us," Panos predicted. "No doubt they'll be frothing and panicking like wild Bacchic maenads."

A garbage container had somehow toppled into the street.

The two men stared at this sudden impromptu monument to a feral dirt and disorder. Since robots meticulously gathered every scrap of the trash of Athens, this was a rare proof that the city's tensile suspension by algorithms had truly snapped.

Alekos and Panos wafted their flashlights over the little puddle of urban chaos. It was the scattering of somebody's seafood feast: crab shells, shrimp tails, chopped bits of fancy octopus salad.

Their flashlights also lit the luminous eyeballs of a small, wandering kitten, which couldn't believe its luck within this cornucopia of generous entropy.

"Hey, wait," said Alekos, rooted to the spot. "I'm having a profound moment of *déjà vu* here."

Attracted by their flashing lights, a female stranger emerged from the gloom. Her sequinned party dress gleamed just like the cat's eyeballs.

"Madame, this moment holds some deeper meaning for me," Alekos told her politely. "It was a radical artwork that I saw once, I think. An ironic happening? Relational aesthetics? Was it performance art? It's terrible to be an old man with memory issues. This suspense is killing me."

"Well, I'm an artist," offered the painted woman in her party dress. "I sing *rembetiko* songs. Because people can have such a lovely time with the saddest songs in the world."

"You're that pretty girl who lives upstairs," said Panos. "The one who busks for social media."

"Sometimes, yes." She talked agreeably, but looked taut and somehow frail. "I own the property rights to eighty square meters inside our *polykatoikia*," she proclaimed. "But since I own access to space rather than any actual walls and floors, I always move every week on Tuesdays."

"My uncle here is a man of tradition," said Panos. "We have much the same legal spatial arrangement that you do, but he insists we should stay rooted to the ground floor."

"We bounce around inside those concrete blockhouses like pinballs," said the randomized nightclub singer. "But we never get to meet except during some little public ruckus."

"And on my very last night in Athens, too," Panos told her.

She offered him the vulnerable smile of an older woman confronting a college student. "Then it must be fate."

"Now I remember it!" said Alekos suddenly. "It's 'The Unswept Floor' by Sosos of Pergamon! That famous ancient mosaic made from Mediterranean seafood garbage. It's mentioned in Book 36 of Pliny's *Natural History*."

"My uncle always complains about his memory," Panos explained, "but just imagine recalling a detail like that without even asking a search engine."

"Our city's lost its memory tonight," said the singer. "Our *polykatoikia* is as dead as stone."

"Oh, come now," said Panos kindly, "even though it's made of concrete, it's sure to reboot somehow."

"I feel like we're three lost people marooned in the 20th century. With all that poverty, pain, police oppression, prison, unrequited love, betrayal and hashish."

Alekos nodded. “That was the primal era for *rembetiko* songs. A soulful woman can live in those old songs just like she lives in an old twentieth-century building.”

“Oh, I know, I know, that’s so true! I don’t even need any music software! I promise, I could play you boys some beautiful analog chords from the strings of my *bouzouki*.”

Panos plucked an empty wine bottle from the garbage. He dropped it precisely onto the edge of the gutter. The glass bottle shattered musically, scattering sharp shards.

“What was that about?” said the singer.

“It’s a little trick they teach us in emergency medical rescue,” said Panos. “Shattered glass always gets the top priority in the urban response algorithms.”

A soft robot oozed soundlessly from the gutter. The urban maintenance device was black, sticky, and had no mechanical parts. Amoeba-like, it surrounded the jagged particles of glass and slowly hauled them back within its native sewer-pipe.

“Well, that proves the town’s low-level software is ticking over,” said Panos, rubbing his pale hands in satisfaction. “All dirt is merely matter-out-of-place.”

“I never saw one of those dreadful soft machines before,” said the singer, blinking at him. “You called it up from the underworld.”

“All the old sewers abound with soft robots. They’re a cheap public health measure, dreamed up by lateral-thinking artificial intelligences,” said Panos. “Superbly efficient, but, yes, a bit creepy. So, us pros don’t often let on about them.”

“What else do you know, that you don’t let on about?” said the singer.

“Oh! Huge, dark Greek tragedies,” Panos teased. “Earthquakes. Volcanoes. Landslides and wildfires. Even when human life seems safe, controlled, and solid, we’re all like Vlassis Kaniaris’ chickenwire mannequins in our hats and empty suits.”

The singer was properly impressed by this erudite art reference. “So. Would you like to come up to my place, and see if you can break in my electronic automated door? A nice guy as well-educated as you can probably hack right through that.”

They walked past many looming ferroconcrete apartment blocks. These omnipresent Athenian *polykatoikia* blocks had been built hastily, with cheap materials and a profiteer’s cheerful contempt for any high architectural quality. But these were the very qualities that made them so robo-mappable and so radically reconfigurable.

“Tonight, you see what our life looks like,” said Alekos, “when fate strips modern urban culture from the old twentieth-century grid. These old polyblocks rose from small, jealously owned little plots of land, to shelter an industrial work force. But we’ve imposed an amorphous and formless soft robotics, and machine-vision mapping. Our modern Athens is like an octopus inhabiting a sunken car.”

“When poverty was filthy,” said the singer, “everyone could see it. Your grime proved you had no one to take care of you. People were matter out of place, like the garbage. A street-singer could see, just from the way that the café-chairs had rudely invaded the street, that the restaurant owner had bribed the cops. That meant you could eat. You could busk and sing and shake down rich tourists for money. The dirt was a kind of permission.”

“We still live inside these concrete blocks,” said Alekos, “although they’re nothing more than heritage sheds for a form of daily life that’s utterly transformed. But Athens might have been truly different. I mean physically different.”

Panos gave the singer a silent, communicative look. The two of them turned to Alekos, determined to politely humor him.

“We might have lived in an Athens devoid of concrete. An insubstantial, Space Age Athens, made entirely of pylons and wires. A suspended city above the rugged earth of Greece, made of rods, cables, glass, and electronic media. I mean, of course, the famous, visionary, Suspended City of... Oh wait a minute... now I can’t remember the guy’s name.”

“When did the architect live?” prompted Alekos.

“In the 1960s, of course! That’s when modern Athens was built. The golden age of the great Greek urban boom! See, instead of this city of cheap cement with media stuffed inside it, we would have had an expensive, aerial city made of media, with just some ancient bits of stone, way up there on the Acropolis.... Oh, what was his name, that forgotten genius?”

“Was he smoking a lot of hashish?” said the singer, skidding on a slight imperfection in the machine-polished sidewalk. She took the arm of Panos.

“No, no, he was a perfectly sober and honest architectural urban reformer, and he died bitterly and tragically, of course,” said Alekos, touching his bald and wrinkled forehead. “His name started with a P, or a T, I think, I’ve almost got it...”

The lights of Athens flashed on, street by street, in a vast progressive wave.

“Oh well, never mind, that’s finished it,” said Alekos, straightening. “It’s done now. Let’s all go home.”

NETWORKS & INFRASTRUCTURES

96

The networks' role has always been decisive for future-oriented scenarios. In the 60s, the city of tomorrow was imagined as a continuously evolving network which, thanks to the up-and-coming systems of communication, information, and transportation, would significantly improve the everyday life. New immaterial architectures would serve the inhabitants with respect to the environment. Nowadays, the electronic networks are at the same time nowhere to be seen and omnipresent. *How do our expectations change in an era of 'clouds,' 'applications,' and 'platforms'? How did the past 'futures' come to life?*

Several works of the exhibition comment on the changes brought by the current condition of constant connectivity, and tackle the sovereignty of today's networks. They address the changes that the networks brought to work and daily life, but also highlight issues of access and ownership of one's data. They expose the infrastructures of today's immaterial networks, underlining their physicality as well as the interdependence of economy, ecology, and technology. They make hypotheses about new network topologies and speculations about their management and control.





Kyriaki Goni, *The Aegean Datahaven: A collaborative platform in the archipelago*, 2017.



Michael Young & the Yale School of Architecture Advanced Studio, *The Icelandic Infrastructure 2036–2056*, 2016.



Victoria University of Wellington, *Birthright*, 2016.
Ava Aghakouchak & Maria Paneta, *Sarotis Wearable Futures*, 2016.

Adam Harvey, *Stealth Wear*, 2013.
New Affiliates & Farzin Farzin, *Time Fears the Pyramids*, 2017.



Takis Ch. Zenetos



Electronic Urbanism is a research project that was in progress for more than 20 years. The first research stage started during Zenetos’ studies in Paris and concluded with the first presentation of the project at the Modern Housing Organization’s exhibition in Athens in 1962. The final project for the “City and the House of the Future” was presented at the 1st Building Exhibition at Zappeion in 1971. In this project, Zenetos adapted his design for an all-purpose furniture that had been distinguished in the “Interdesign 2000” competition (1967).

Zenetos’ project for the city of the future was the outcome of systematic research on the development of applications in electronics. Studying articles in scientific journals of the time, Zenetos defined accurately the forthcoming applications of ‘tele-management,’ ‘tele-work’ and ‘tele-services.’ Taking into consideration the accelerating changes of living elements in the cities of the future, he proposed flexible systems for both building and infrastructures. He believed that the structure of the city and the house of tomorrow would have to be ephemeral and, as much as possible, immaterial. For this reason, he designed a system of light three-dimensional supporting cable-structures, like a spider’s web, containing vertical garden-cities and dense networks of improved telecommunications media. The ground, which was left almost free, was an uninterrupted natural space as the city would expand over forests, lakes, rivers, and seas.

This space structure can receive any type of infill elements, but the most important one is that of the moveable tele-processing cell. An anthropomorphic all-purpose furniture controls the tele-activities, the audiovisual contacts, and the environmental conditions. The adjustment of the furniture’s various parts is mechanical through keys, but Zenetos had already forecasted that in the future this would be controlled directly by the user’s brain, with the help of a hyper-sensitive electro-brain waves receiver.

Project team:
T.Ch. Zenetos with
T. Exarchopoulos, M. Marmaras,
E.G. Biris, A.N. Papanastasiou,
P. Poursanidou-Athanassiadou,
M. Tzougas (architects) and
S. Angelidis, D. Bairaktaris
(consultant engineers)

All publication material belongs to the Takis Ch. Zenetos archive.

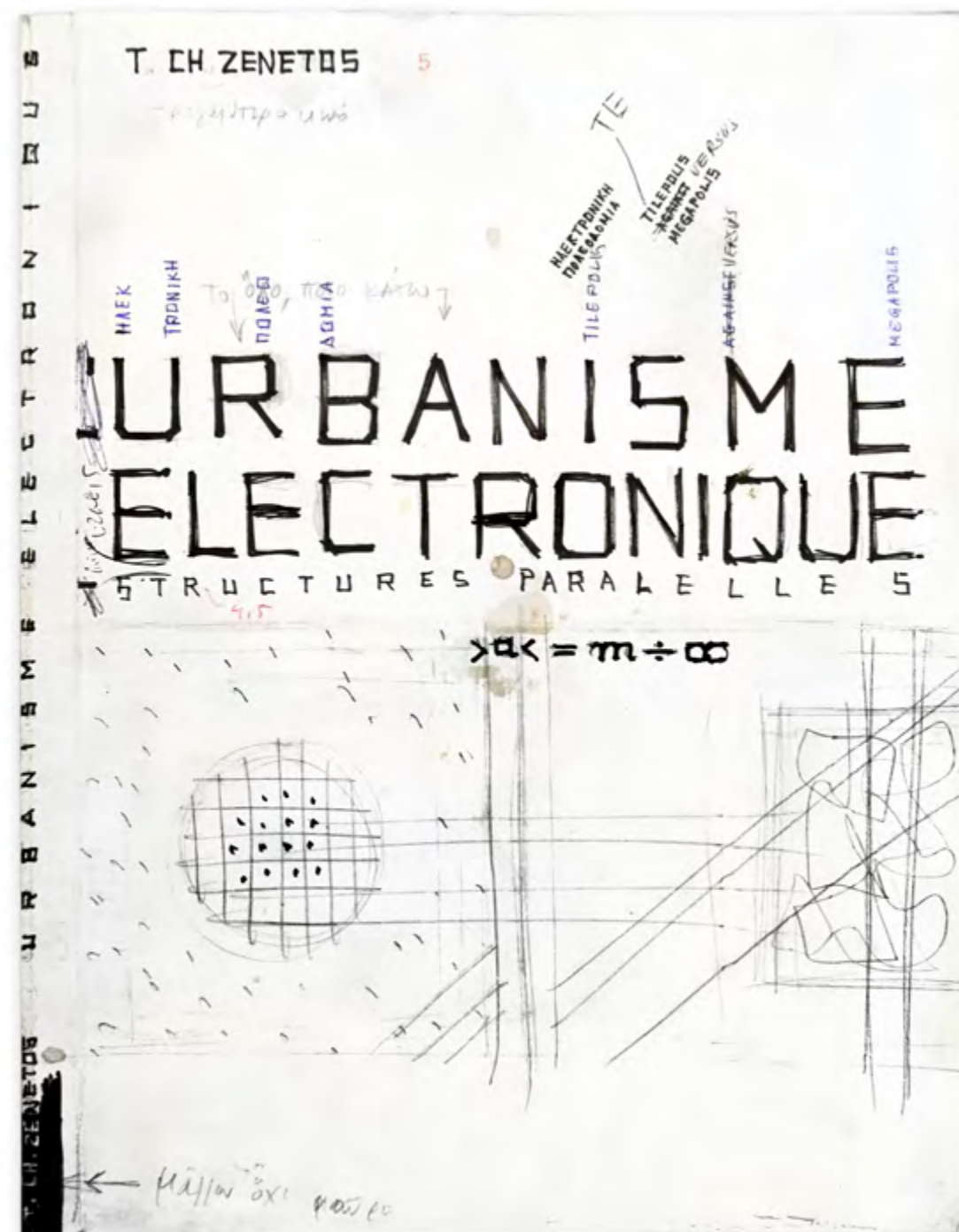

Opposite page: City and the house of the future. Model (1971). Dwelling area for four people.
Current page: Cover layout sketch for the book *Urbanisme électronique: structures parallèles*.

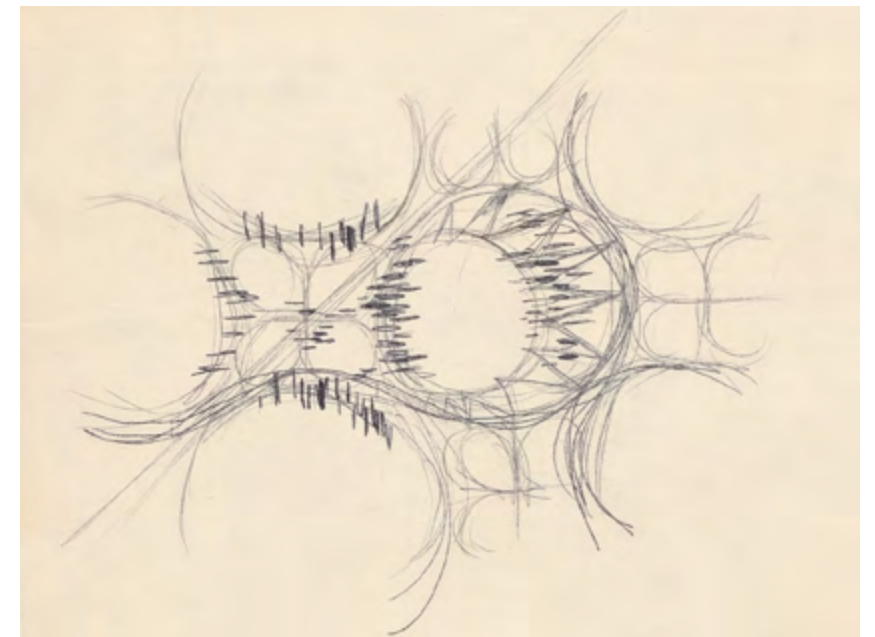
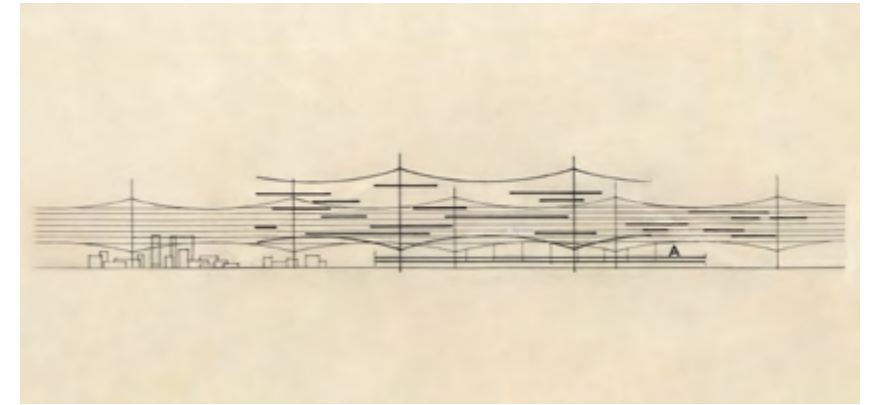
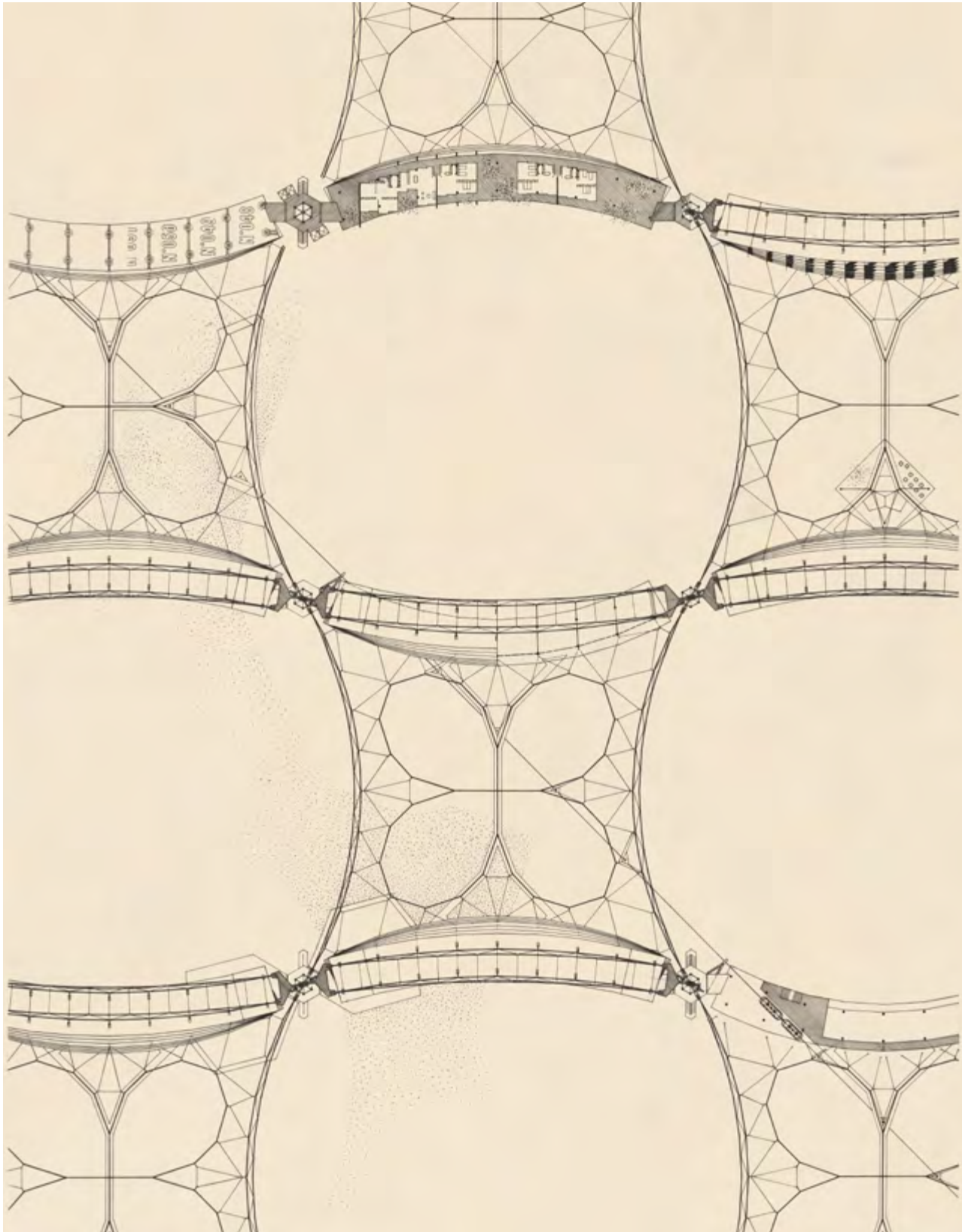

Opposite page: Plan of the urban grid (1962).
Current page
Top: Section (1962).
Center: Plan (1962). Variations in form and density.
Bottom: Sketch (1962).

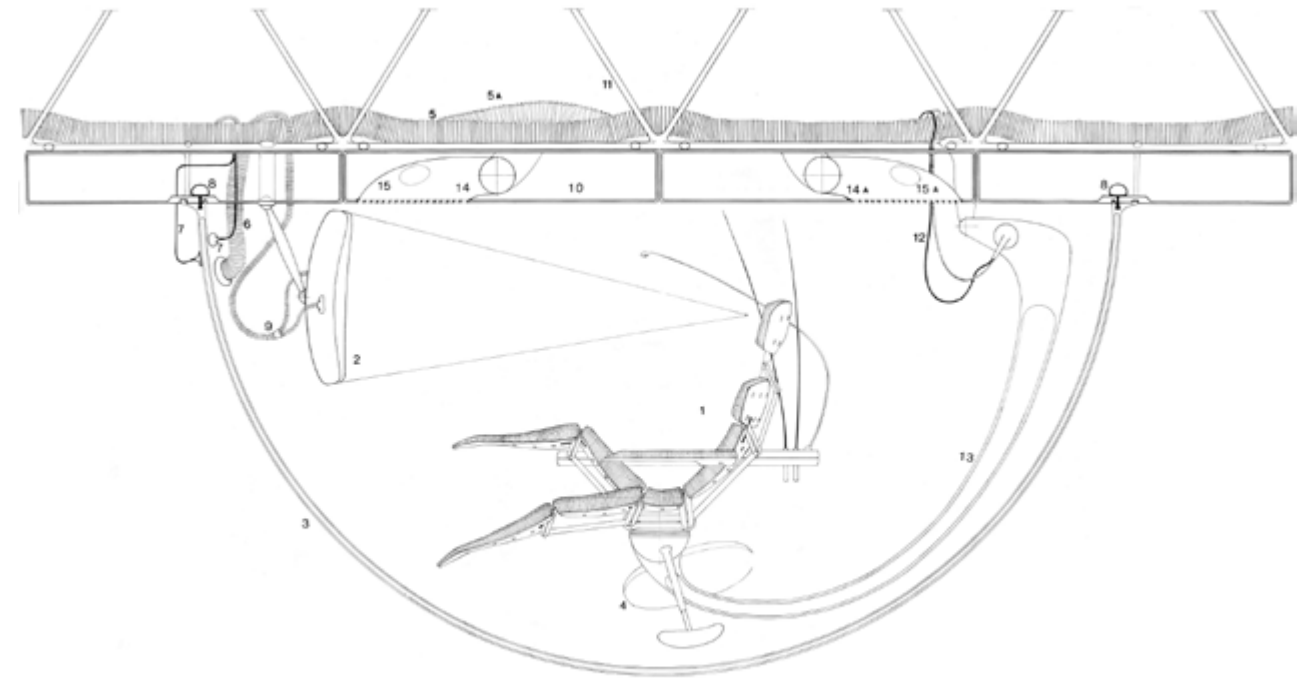
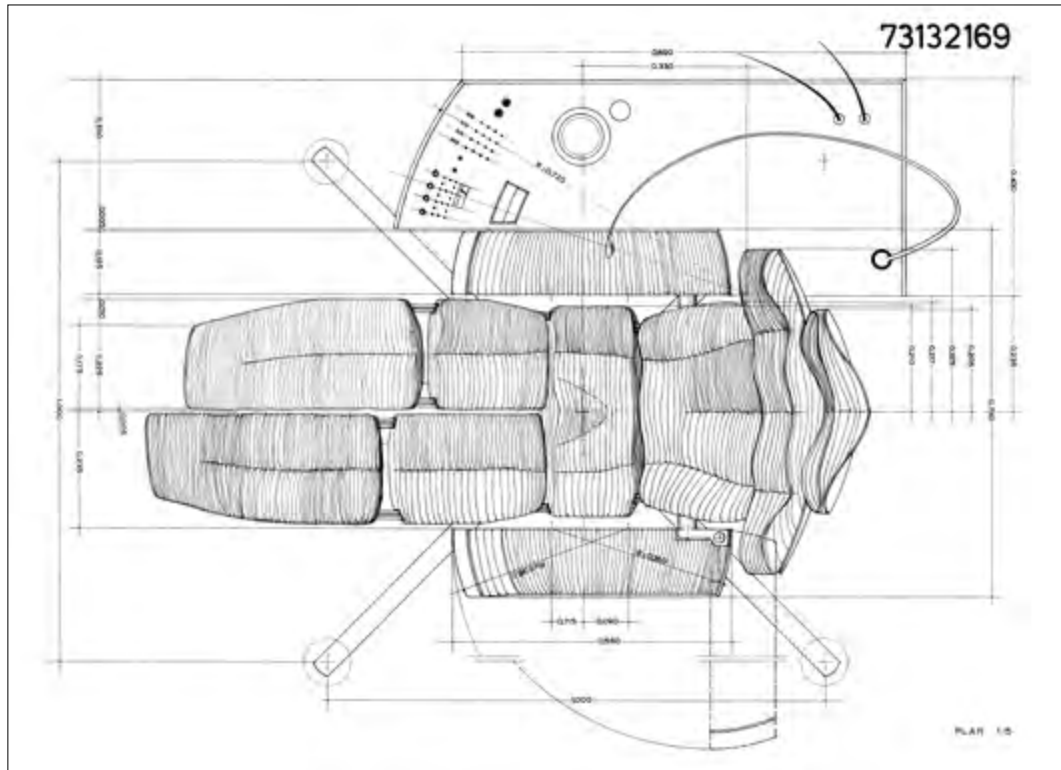
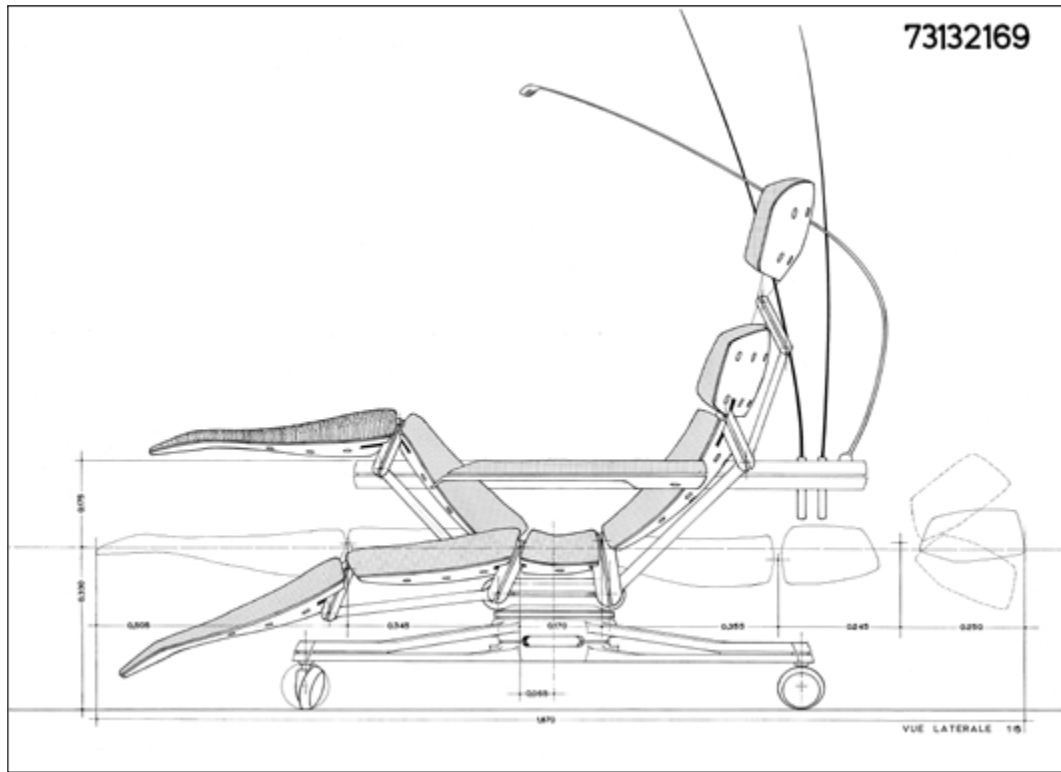

Opposite page
 Top: Participation in the "Interdesign 2000" design competition. Section (1967).
 Bottom: Participation in the "Interdesign 2000" design competition. Plan (1967).
 Current page
 Top: City and the house of the future. Section detail (1971).
 Tele-processing cell: 1. Mobile jointed 'body-carrier' of multiple use, and tele-operations keyboard / 2. Tele-activities screen / 3. Double transparent cell membrane / 4. Entrance opening for vertical transportation by fork-lift / 5. Air-conditioning duct-supply / 5A. Air-conditioning duct-section / 6. Supply of transparency regulating liquid between the skins of the double membrane / 7. Power supply to activate phosphorising particles, used for illuminating the cell interior or the exterior environment / 8. Ring fastening for the cell / 9. Tele-contact screen outlets and monitors / 10. Roofing elements / 11. 'Carrier' grid of synthetic material / 12. Outlets of the jointed 'body-carrier' - tele-activities keyboard unit / 13. Suspension arm of the 'body-carrier' / 14. & 14A. Air-conditioning muzzle, supply-suction / 15. & 15A. Spray cleaning and drying of the cell during the 'operator's' absence; suction of dust/dirt particles.
 Bottom: Sketch (1971).

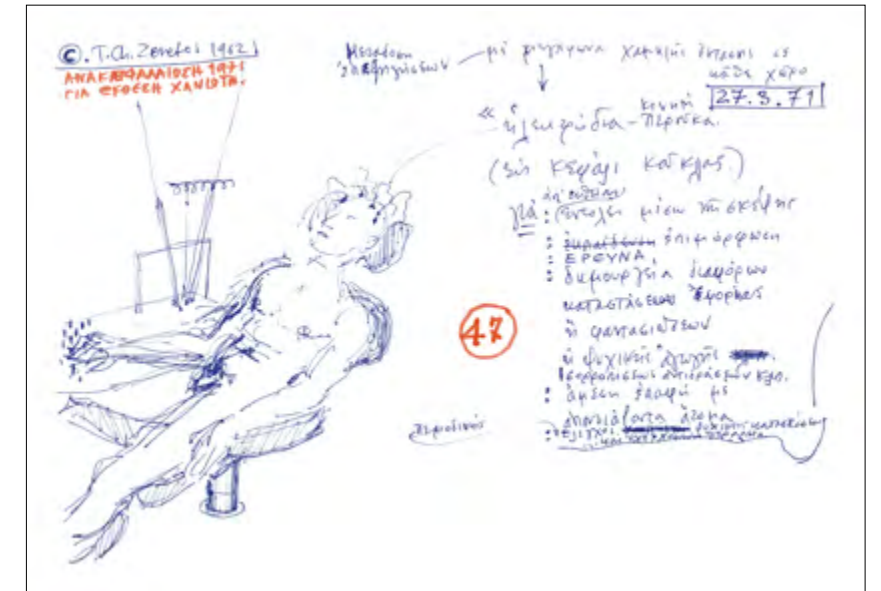

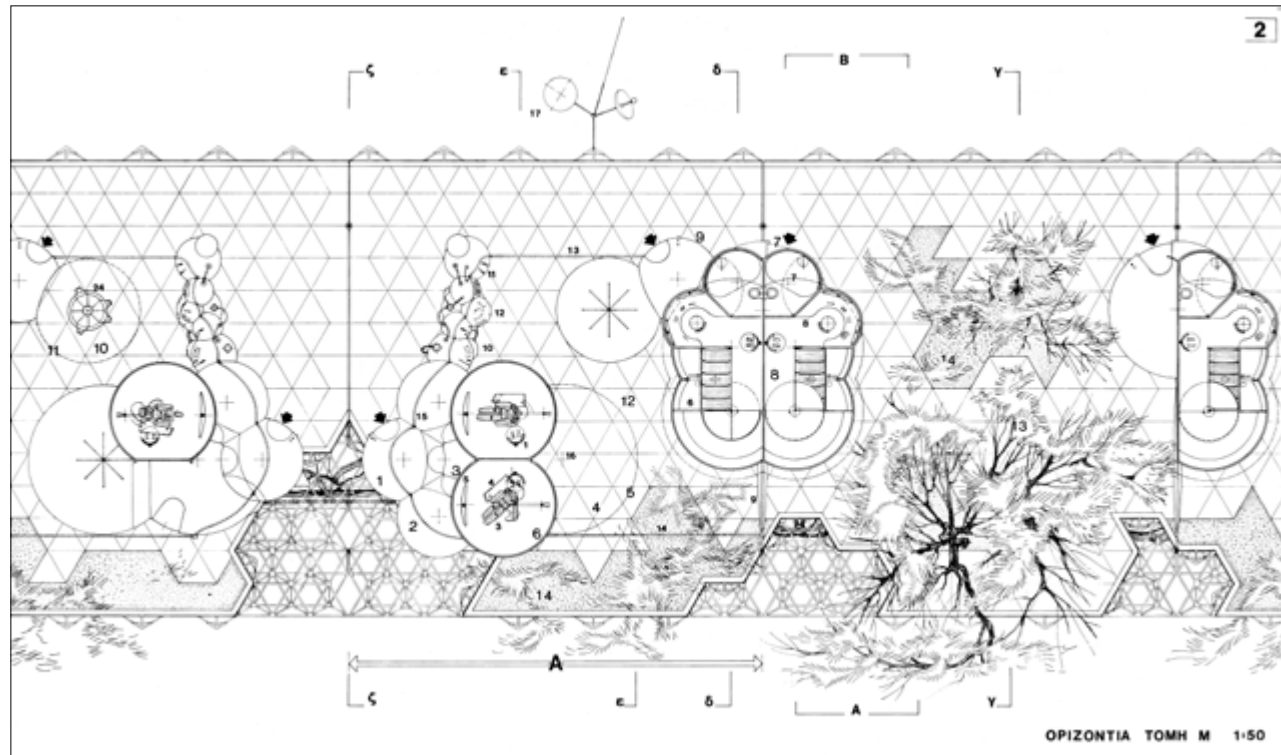

City and the house of the future. Horizontal section at roof level (1971).

A. Dwelling space for four people. (Large numbers)

Group of elements for a couple: 1. Private entrance cell; transitional element from the outdoors to the climatically controlled space / 2. Private hygiene cell ('catholic shower,' spraying etc.) / 3. Connecting cell / 4. Space for the couple's contacts, rest, 'instant' sleep / 5. Folding isolation skin / 6. Individual tele-activity cell (upper level; elements 1 to 5 are on the lower level).

Group of elements for children: 7. Entrance cell, games room (lower level) / 8. Individual element (upper level).

Other elements: 9. Visitors' entrance cell / 10. Space for contacts, meals, discussions of the subgroup / 11. Folding isolation skin / 12. Large-group and small-group contact area, of multiple space and use potential / 13. Public piazza / 14. Garden.

(Small numbers)

1. Fork-lift for vertical connections / 3. Multiple-purpose mobile jointed 'body carrier' / 4. Tele-activities switchboard / 5. Tele-contact screens / 6. Sleeping-isolation cell (child's element) / 7. Hygiene cell / 8. Tele-education cell / 9. Screen wall for contacting people, environments, spectacles etc. / 10. Tele-operating and tele-monitoring switch connecting different locations in the area / 11. Terminal / 12. Laboratory for the composition (and decomposition) of consumer goods (closed circuits) with water and basic substances supply installation / 13. Screen of varying transparency grades and varying height / 14. Air-screen of controlled density through refraction particles (of various radiation groups) / 15. Air-screen supply tube (as 14.), in this instance elastic to adjust to cell curvatures / 16. Flexible floor surface / 17. Sunrays collection system / 24. Food-supply element.

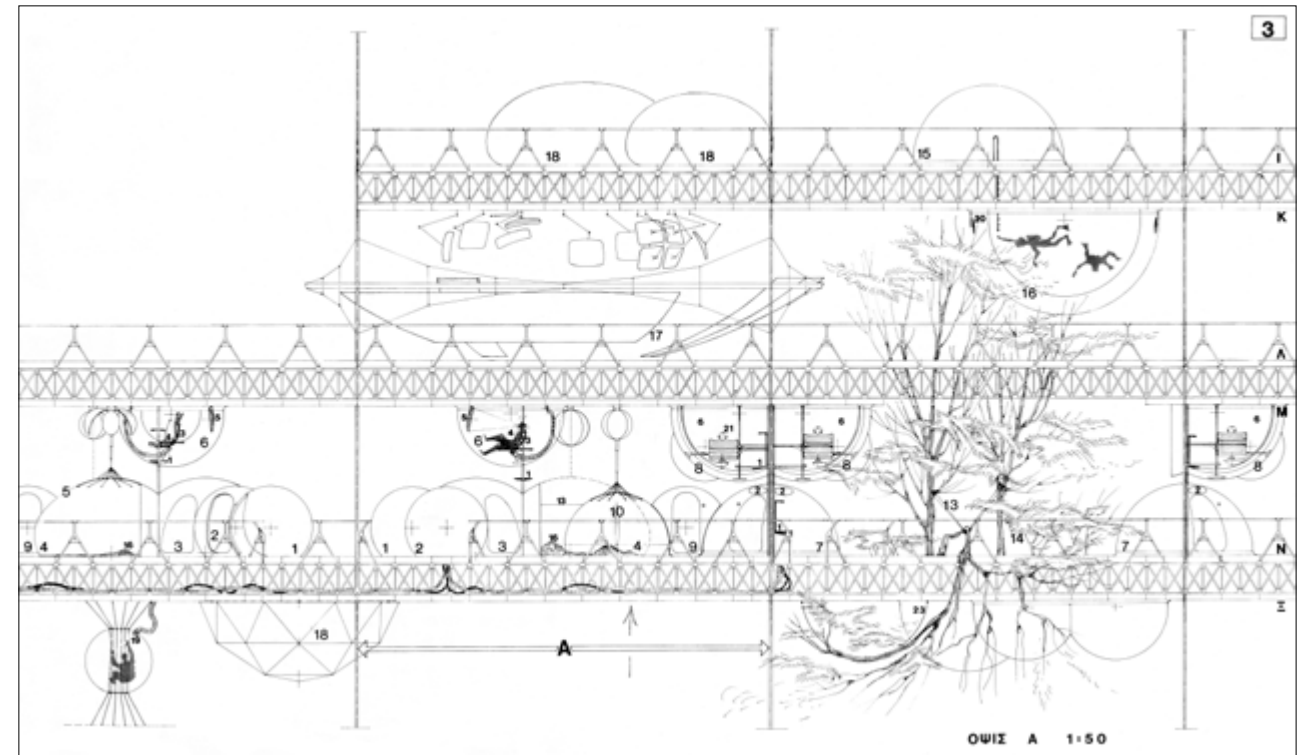

City and the house of the future. Elevation. Partial view of the urban space grid (1971).

A. Dwelling space for four people. (Large numbers)

Group of elements for a couple: 1. Private entrance cell; transitional element from the outdoors to the climatically controlled space / 2. Private hygiene cell ('catholic shower,' spraying etc.) / 3. Connecting cell / 4. Space for the couple's contacts, rest, 'instant' sleep / 5. Folding isolation skin / 6. Individual tele-activity cell.

Group of elements for children: 7. Entrance cell, games room / 8. Individual element. Other elements: 9. Visitors' entrance cell / 10. Space for contacts, meals, discussions of the subgroup / 13. Public piazza / 14. Garden / 15. Entrance cell to element / 16. Cell for suspension experiences, space viewing etc.

(transparent swimming-pool cell) / 17. Social activities area, situations simulation, 'instant' theatre etc. / 18. Elements available on the market.

(Small numbers)

1. Fork-lift for vertical connections / 2. Entrance opening to cell / 3. Multi-purpose mobile jointed 'body carrier' / 4. Tele-activities switchboard / 5. Tele-contact screens / 6. Sleeping-isolation cell (child's element) / 13. Screen of varying transparency grades and varying height / 16. Flexible floor surface (static situation: flat surface / dynamic situation: relief surface following the contours of the body in each consecutive posture) / 19. Gym equipment for bodily exercise / 20. Hydromegaphones for 'music' broadcasting / 21. Acoustic isolation earphones / 23. Support for plant climbers.



Opposite page:
City and the house of the future. Model (1971).
Current page
Top: "Interdesign 2000" design competition.
Model (1967).
Bottom: City and the house of the future.
Model (1971).
Photos by Mariana Bisti.



**The Aegean Datahaven:
A collaborative platform in
the archipelago**

2017

Kyriaki Goni



The Mediterranean Sea, in the sidelined European South, has been the stage of major tensions and urgencies due to its geographical particularity and cultural diversity: climate change, population movements, financial crisis, military and political conflicts, tourist exploitation. Part of the Mediterranean Sea, the Aegean archipelago connects but also divides two continents being therefore of crucial importance for many centuries in this area. Having opposed numerous gentrification attempts and investment plans during the last decades, the archipelago is found to accommodate in the future a decentralized network of small, fully sustainable, climate-controlled data centers, constructed on the islands or floating on the water, which enables people to safely and privately store and share their digital information and memory without relying on any kind of corporate cloud. This network of data centers managed by the islanders brings into form a kind of local traditional platform cooperativism. The islanders' community consists of people who abandoned the urban centers of Europe, former refugees and indigenous islanders. In the face of the harsh and erratic regional conditions, the *Aegean Datahaven* connects the islands with each other creating new topologies and questioning at the same time the established forms of sovereignty, identity, geography and power. An extended archive of the data centers can be found in the *Aegean Datahaven* collection. The data centers are depicted on a series of drawings by an unknown traveler.

Project team:
**Kyriaki Goni with
Thanos Eleftherakos**

aegeandatahaven.com



Opposite Page: *The Antiparos Databunker in 2091*. Drawing by an unknown traveler.

Current Page: *The Schinoussa Datacenter in 2085*. Drawing by an unknown traveler.

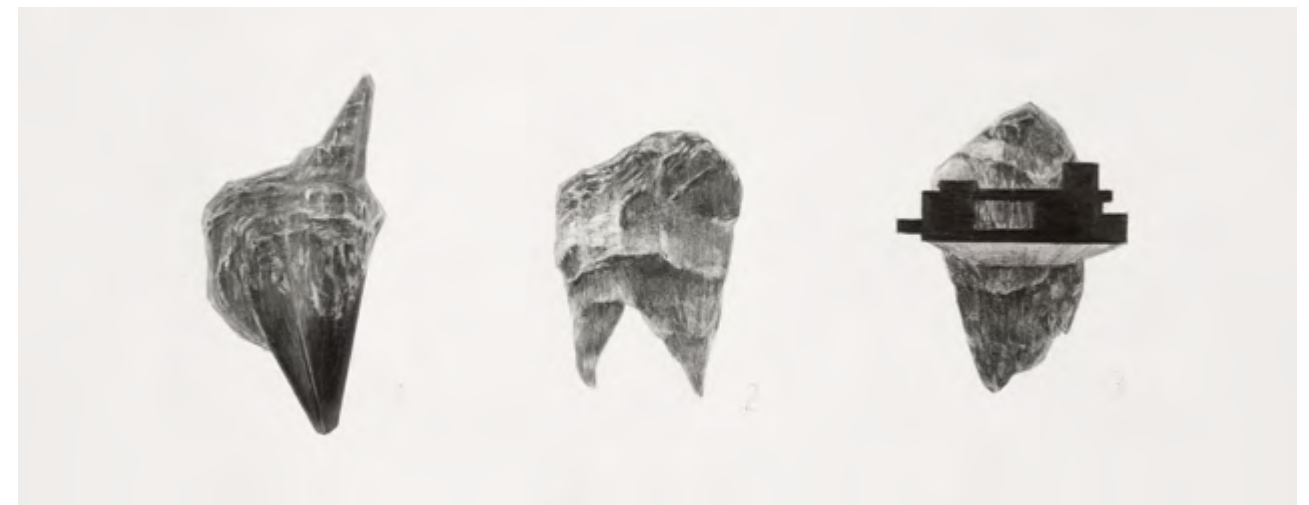
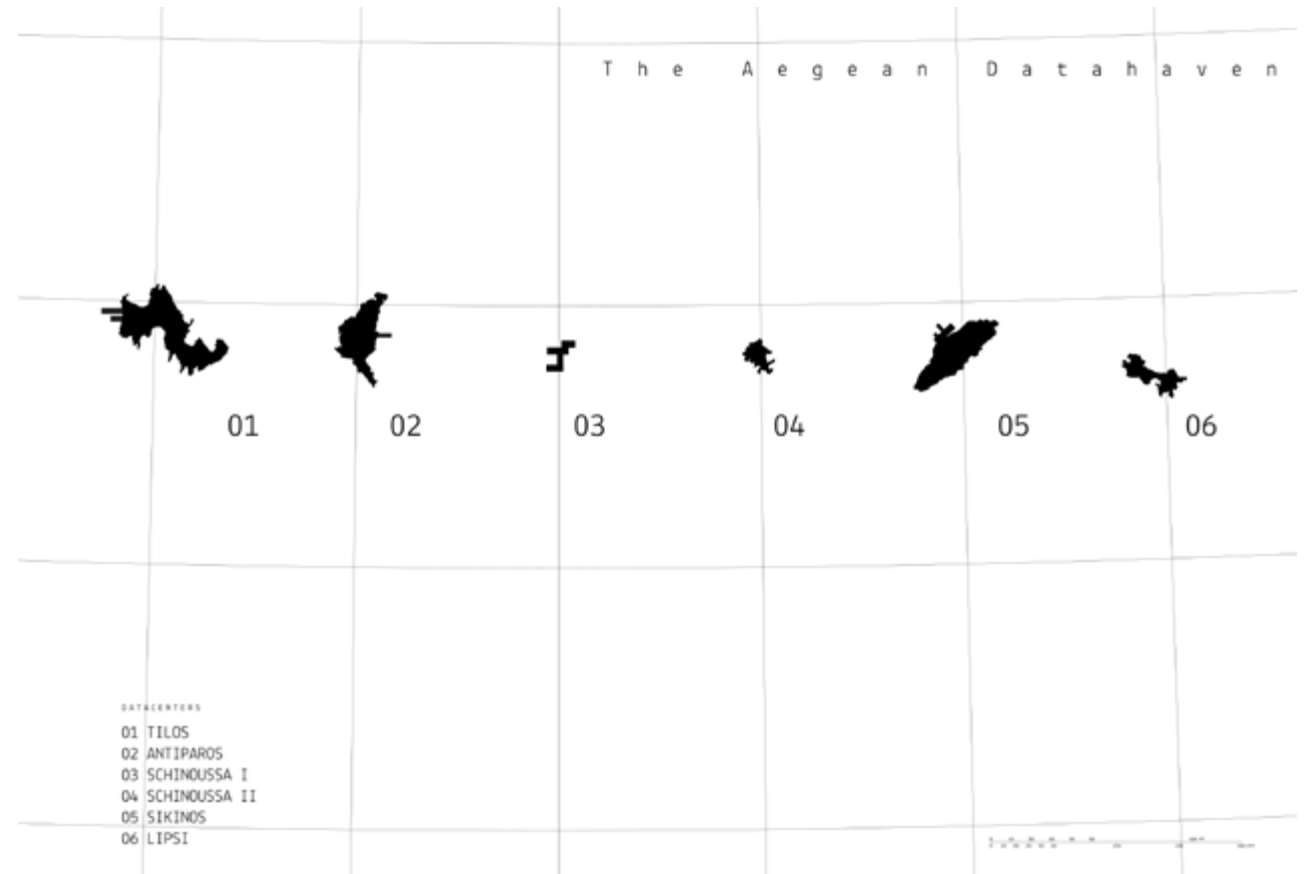

Oposite Page:
*The Aegean archipelago. The sea of data
 in 2085. Drawing by an unknown traveler.*

Current Page
 Top: *Interactive map.*
 Bottom: *Aegean archipelago. Databunkers in
 2089. Drawing by an unknown traveler.*

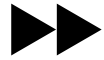

**Michael Young &
the Yale School
of Architecture
Advanced Studio**

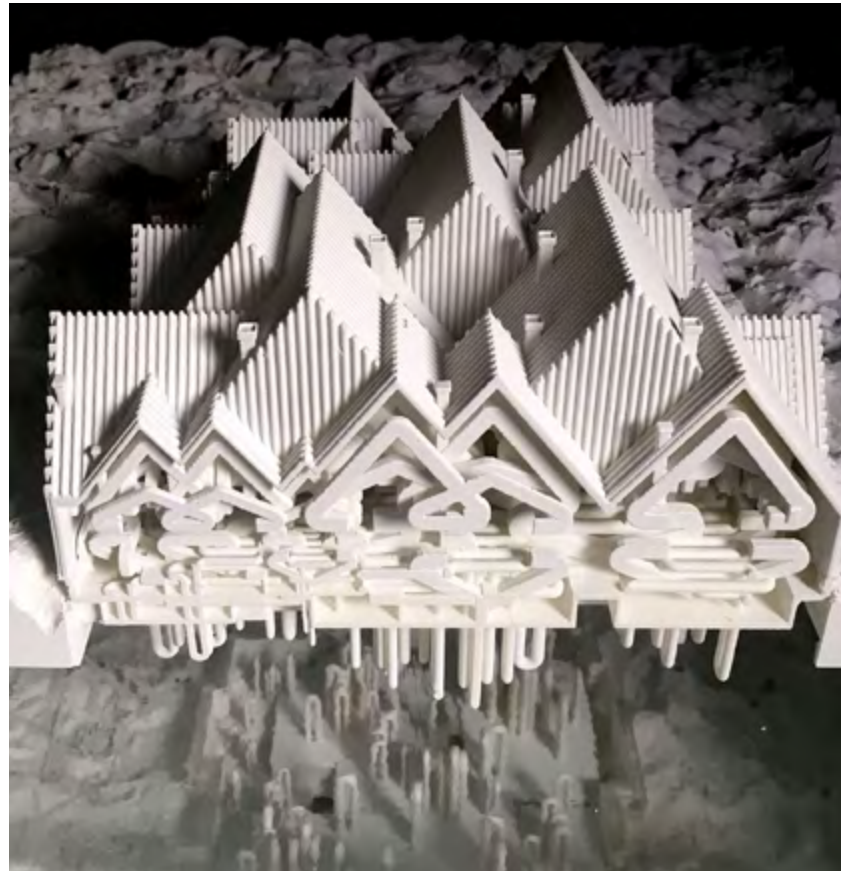

In the fall of 2016, nine students at the Yale University School of Architecture documented the future infrastructure of Iceland over a 20-year period from 2036 to 2056. This was a speculative archival project 20 years in the past of 40 years from now. The infrastructure was rethought in light of contemporary developments in ecology, technology, and economics; these three issues effect the cultural relations of the built environment at such an accelerating pace that is difficult for a discipline such as architecture to grapple with. The question that the studio dealt with is not the fantasy that architecture can solve these problems, but that architecture is responsible for imagining the aesthetics that the interrelations of these three would provoke in the near future. The participants explored how these accelerated changes redistribute sensible information, and therefore involve politics. The projects presented range in scale and issues addressed. Three general categories were developed, although each project crossed over into the others: *Energy Extraction*, *Distribution Systems*, and *Information Storage*. Each project is documented through 9 images, 1 model, a brief text, and a presentation of research documenting the future media.

Project team:
**Michael Young with
Heather Bizon, Matthew Bohne,
Pauline Caubel, Cathryn Garcia-
Menoca, Paul Lorenz, Aymar
Marino-Maza, Steven McNamara,
Maggie Tsang, Rob Yoos**

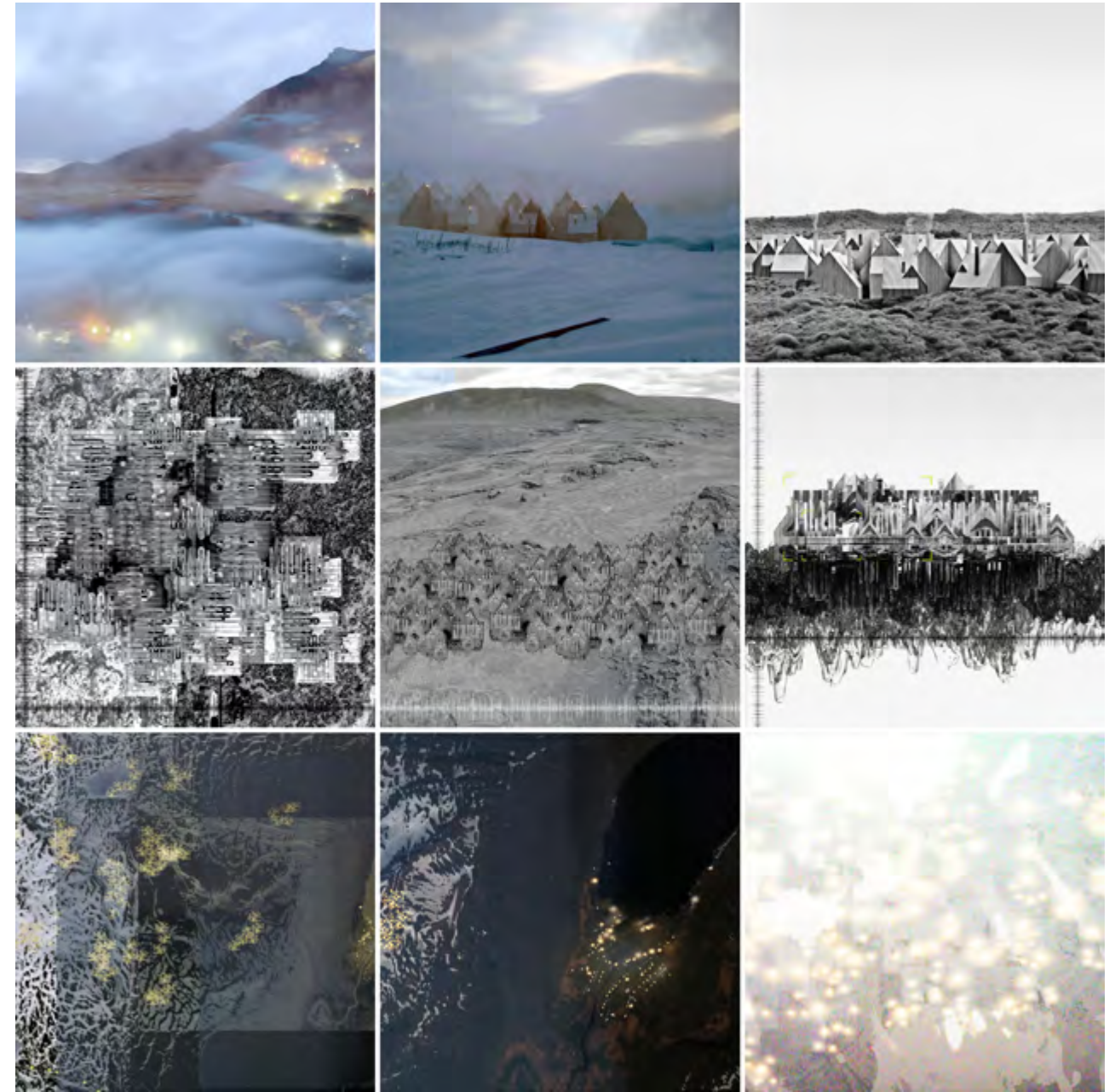

Heather Bizon, *In Plain Sight*, 2016.
In the late 2030s, the shed company, Hexal, began distributing prefabricated systems. The entire infrastructure is kind-of hidden. Mines, power generators, processing plants, coders, hackers, satellites, undersea cables, transmission towers, etc. What appeared to be some of the most prosaic and banal structures in the modern Icelandic landscape are part of a global infrastructure. These structures seemingly stand as isolated towns. Off the grid from larger support systems working in an extreme localized system. Hyper insulated, exhausted, heated and cooled. Off the grid.

Matthew Bohne, *Iceland Resolution: The View from Nowhere*, 2016.

Iceland is one of the most geologically active sites on the planet; providing vast and variegated energy-rich geologic ecologies. As commercial energy development accelerates so does the encounter with new dissolved solids, toxic metals and corrosive gases. In order to meet the demand for energy production, Networkx developed roving regulating and ventilation chambers that are able to be repositioned over ongoing drilling operations. The roving chambers, in their design, have left trails of sulfuric rock deposits, from the granular to the monolithic. The “beasts” or *dýrið*, as they are referred to by locals, have become the center of argument between conservation and industrialization.



Pauline Caubel, *Tesla Redoux - Iceland Probe System Report*, 2016.

As global warming accelerated, the exploitation of Icelandic glacial crevasses for wireless power transmission escalated. Cables puncturing the most central glacier, Hofsjökyl, from all directions harvest the kinetic energy from the shifting landscape. A system of stations planted across the natural crevasses facilitates wireless transmissions across Iceland. As global warming further impacted the cracking of glaciers, the Icelandic Probe System expanded exponentially. What was once a sustainable infrastructural program became an exploitation of Iceland's landscape. The growth in numbers of these probes led to a lack of maintenance, causing many to collapse into the crevasses.



Cathryn Garcia-Menoca, *The Glacial Genome: Looking Back at the Mid-Atlantic Mediation Project*, 2016.

The pioneering Mid-Atlantic Mediation Project (MAMP) was one of the most important data infrastructure projects of the 21st century. Using a network of IASP self-boring probes, each fed by a fleet of UAV's (Unmanned Air Vehicles), the glacier was translated into an ever-changing cloud of information and therefore able to be surveilled and altered. The previously impervious mega-structure of the glacier was converted to a responsive data set. Much in the way that galaxies, governments and genomes are meticulously mapped, the MAMP produced incredible infrastructural architectures and an intimate understanding of our terrestrial home.



Paul J. Lorenz, *InfoState Infrastructure*, 2016.

In tracing the digital activity of InfoState NCE33 (Nevvy Oktyabr), we have followed the group's obsession with the legendary 'Beowulf Cluster.' Our research team assumed that the Beowulf Cluster was simply shorthand for any large, high throughput slaved botnet. Late in 2055, our network forensics collaborators in Charlottesville came to the shocking understanding that Nevvy Oktyabr's concentrated decryption attacks seen in 2049-50 originated from a single geo-located point. Here, we will describe our discoveries from the physical Beowulf Cluster site. While the hardware is already a few years into obsolescence, it may begin to explain the belligerent use of contemporary (possibly geo-located) computation clusters.

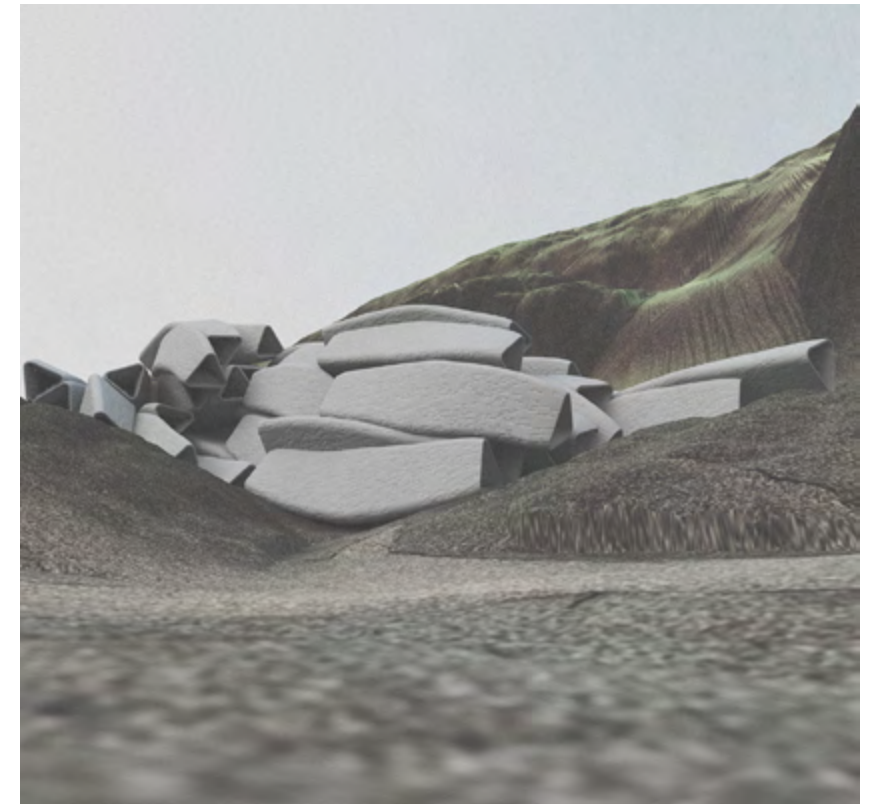

Aymar Marino-Maza, *From BIM to Garage Bands: The Rise of Energy Hacking*, 2016. *The Mat* was a geologically-modified nano-structure that dispensed energy across vast distances with minimal losses. Leading this venture was Matrix Corp. Their Matrix House, a BIM-generated fully-controlled building system, harnessed energy through the floor and containing it through the roof. It was hailed the experimental green building of the decade. Yet, with fame came worldwide criticism. *The Mat* served to monitor and exploit its inhabitants for consumer driven intentions. The public hadn't just entered into our home through our devices, but our homes themselves had become the forms of control, and people were alarmed. The project was abandoned. But some of these houses remain, left as remnants of the utopian dream of universal shared energy.

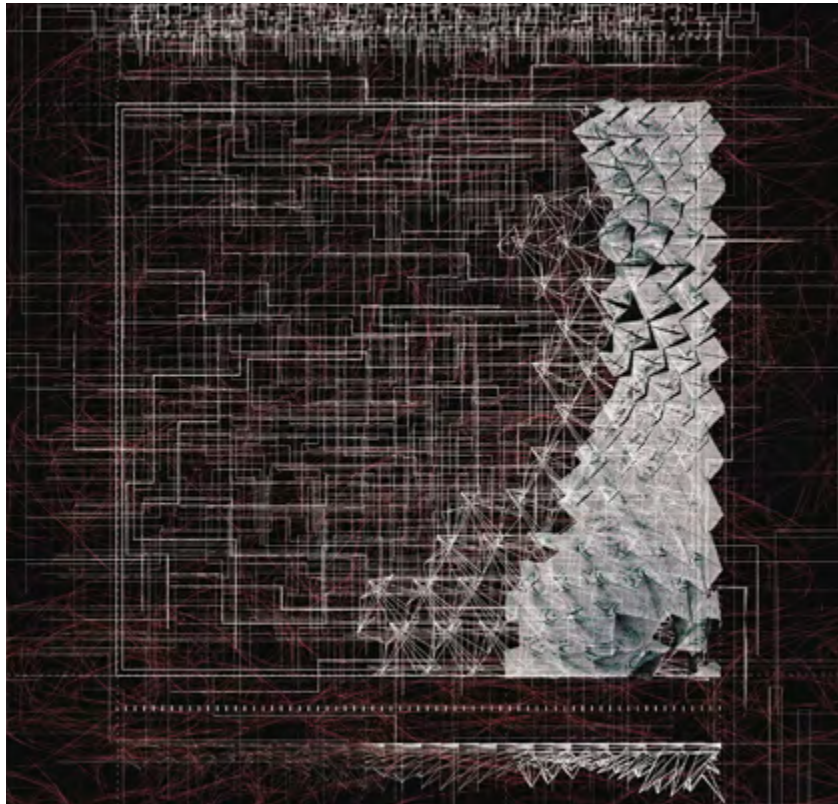

Steven McNamara, *The Hive: The Distribution of the Many*, 2016. The tourist, yearning for an adventure, purchases a package for the Icelandic Wilderness Park. Advertised as everyone's ideal form of touring, the trip will drop them into the remoteness of Iceland, with a guarantee that they will not encounter another. Robotic in its motions, the building is tuned to sort and package users for isolation from the moment they land. The pod's arm is extended and angled based on the trajectory of travel to the pre-determined location. Compressed air traveling from the pneumatic plant at the base is released into the pod's mechanics and pop. Surprised on their return to find the lift does not open into their pod as expected. Instead, the tourist is centered in a microcosm suspended inside the drum. It's a party.

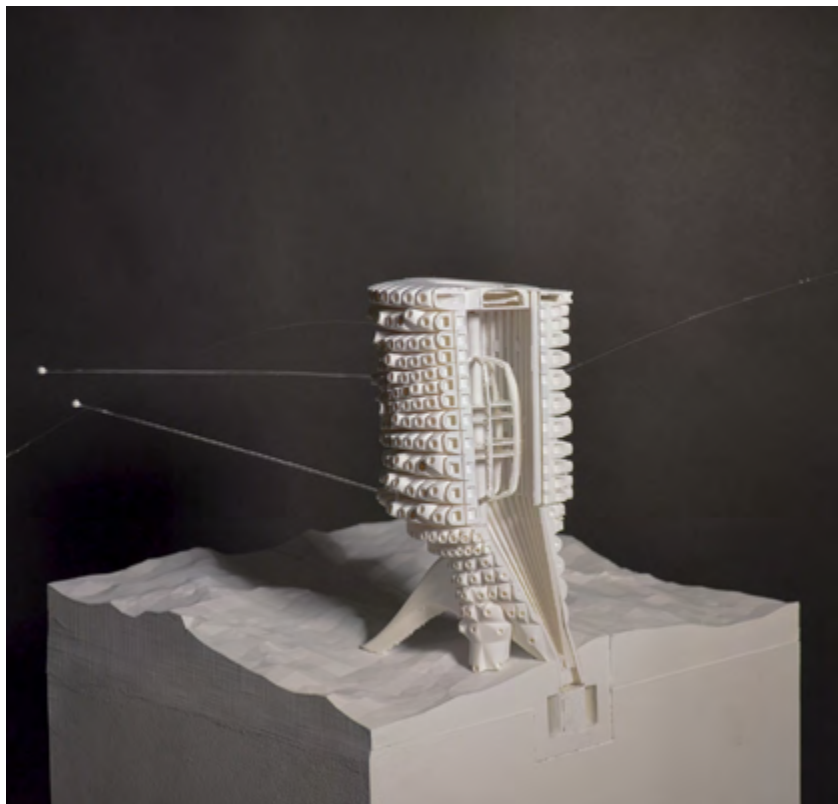

Maggie Tsang, *Data Landscaping: The Highland Dermis*, 2016.

A forest of slender poles forms the neural surface of an extensive infrastructure of data harvesting and storage, hidden from the tourist's gaze, that was constructed in 2036. This hinterland back-of-house is home to the nation's densest, and fastest growing, collection of server columns. Here, the earth's crust is made of rare metals. This mechanical interface replaces the cell tower and bulky data center; and instead it collapses the hardwares of data and heat transfer into one compact system that disperses signal and mechanical loads across thousands of small nodes that blanket delineated swathes of land.

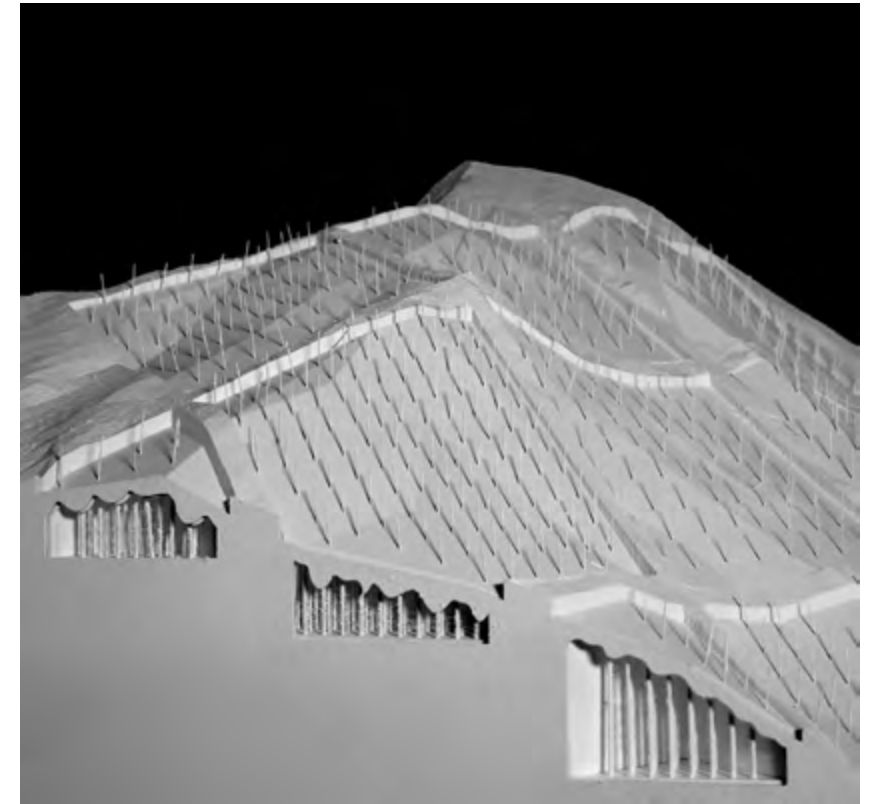

Rob Yoos, *Razor Mining: Refueling the Cloud*, 2016.

In 2024, the Icelandic government commissioned the Icelandic Mining Technology Initiative to develop a system for extracting Phreatomagmite. The committee called for an economical mining operation that could handle waste in a manner that would not drastically disrupt the appearance of the landscape. The world's first razor mining operation has been fully operational since 2036, but has become increasingly embroiled in controversy over mounting ecological concerns surrounding its terraformed byproduct. The future of the project remains uncertain as the geopolitical implications grow increasingly contentious with each additional scar on the land.

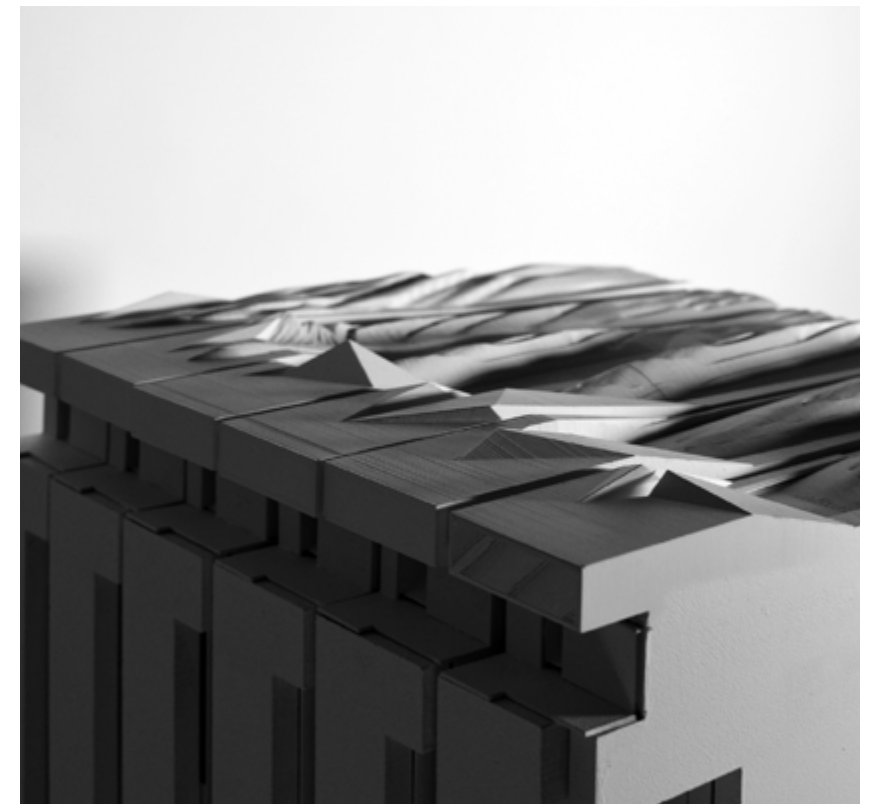

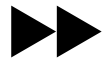

New Affiliates & Farzin Farzin

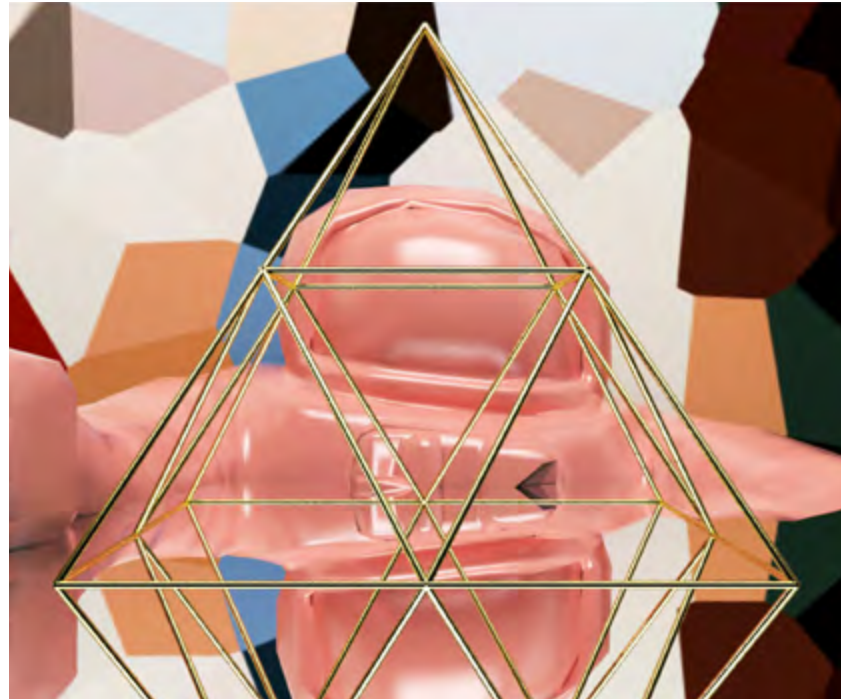

We largely conflate technology with speed, imagining near futures that are dystopian and accelerated, efficient and lifeless. Technology is exclusively considered fast, dynamic, frenetic. The future is closer than it may appear – maybe just an invention away. It moves at the speed of a signal, transforms instantly, and displaces generations in ever-shorter cycles. But technology can move as slow as it does fast. *What if we considered how it might resist progress, counter efficiency and derail optimization?*

Man fears time; time fears the pyramids, warns a 12th century Arab proverb. We understand the pyramid as the most enduring form of resistance: weathering the storms of humanity and cultural change. Pyramids allure us with myth, with scale, and with the impossibility of their construction. They seduce us with their platonic clarity, elemental materiality and ambiguous use. They withstand. They are a bit ridiculous.

For *Tomorrows*, the New Affiliates have produced a pyramid generator: a black box process that samples from the digital universe to produce new kinds of pyramids every four minutes. Whatever is plugged into the generator will read the pyramids: bring a printer, and you'll soon find a stack of post-cards; plug in your phone, and they'll pop up on screen; attach a speaker and you'll hear them described. Yet no matter your engagement, no matter the state of technological progress, and no matter time, the generator will continue forever; producing an infinite set of relations, networks and data all reduced to a platonic that only knows to resist.

Project team:
Ivi Diamantopoulou, Jaffer Kolb,
Farzin Lotfi-Jam, James Turle

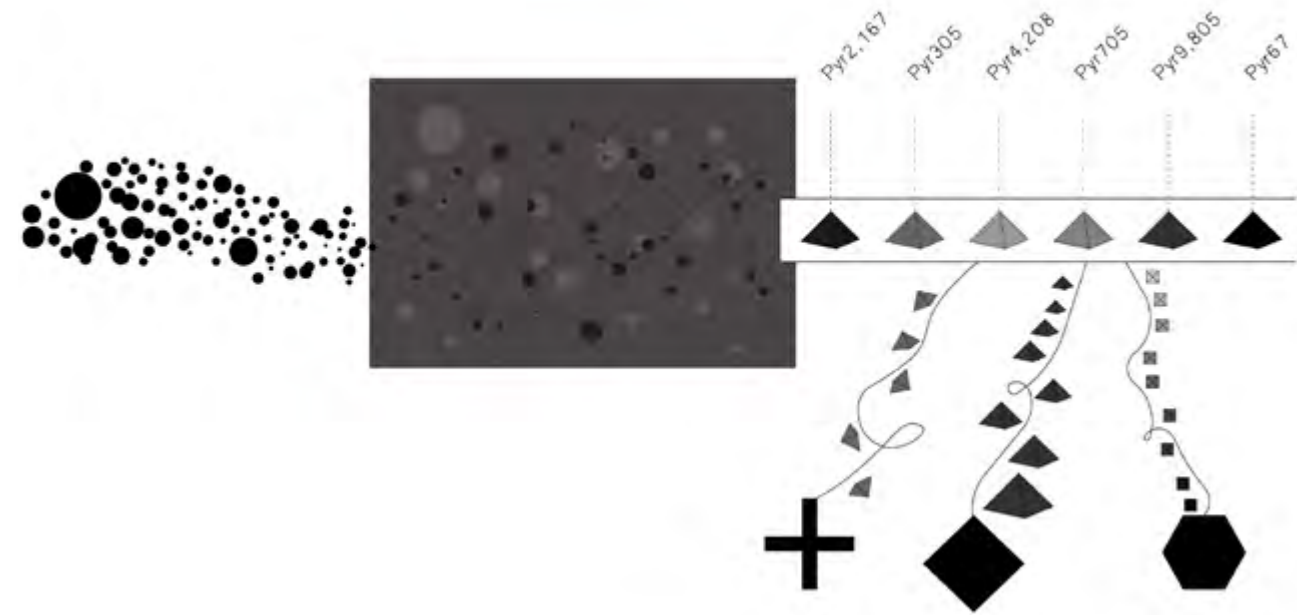

Oposite Page:
Output 64.403: an HP Deskjet 1112 plugged into the Pyramid Generator printed out this pyramid, drawn from a random data aggregator that led to an article about the MTV cartoon *Daria*. The same pyramid simultaneously flashed on a television monitor, overlaid the home screen of an iPad, scrolled across a storefront LED sign, and interrupted a live recording on a local radio station. Thirty seconds later, it disappeared. Four minutes later, a new pyramid was generated.

Current Page
Top: A black-box process scours the world through local and global networks, arbitrarily finding data to translate into novel pyramids. As an aggregator, it disregards types of information and might sample from any source; as a generator, we know not how it translates the data, but only that its manifestation is determined by the plug-ins. The generator is independently operating, requiring neither new information nor human intervention. It will keep operating indefinitely.

Bottom: Data is processed into pyramids of many kinds, depending on what you plug in to the generator. For the exhibition: monitors, printers, a speaker, a LED sign.



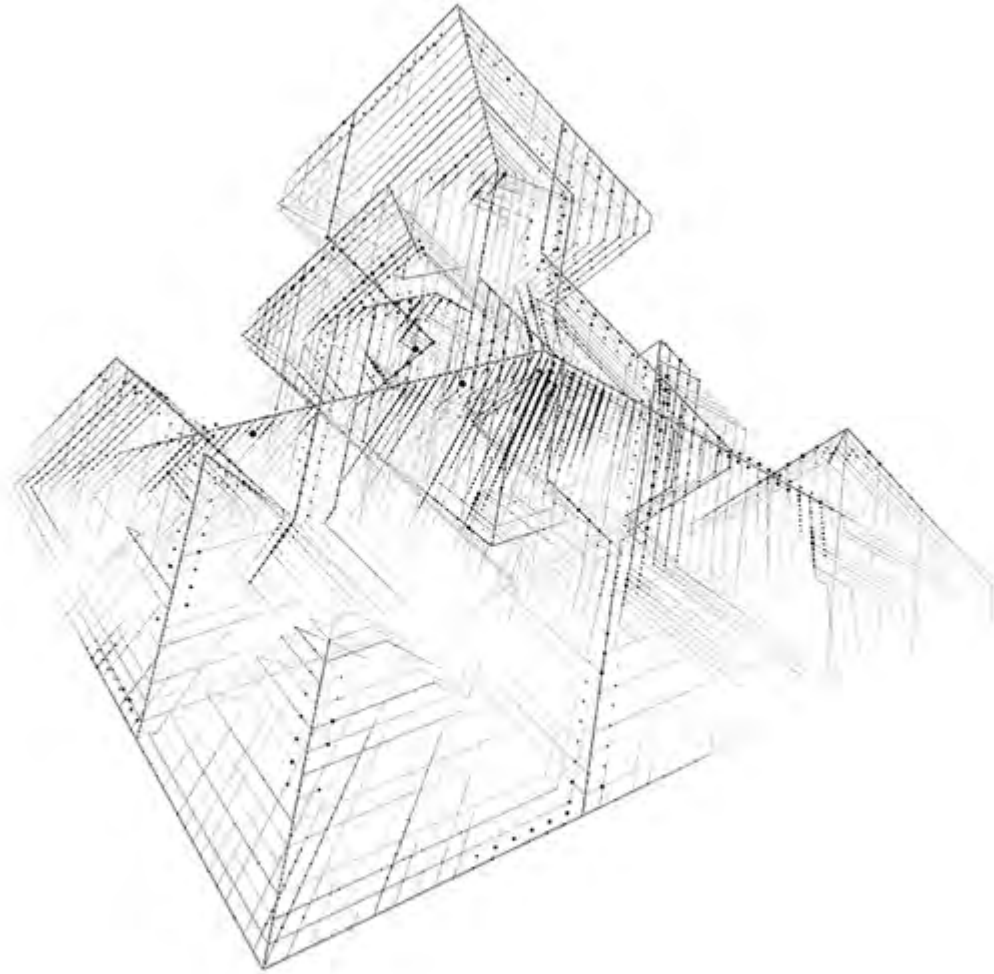

Above: Pyramid, animation still.
 Opposite Page: 8 of the first 250 pyramids
 produced at Tomorrows.

Pyramid wage increase: will it really hurt the economy?



Keyword: Microsoft Outlook Theme: business

From La La Pyramid to Wag: the best of film and TV streaming is available in Pyramid



Keyword: Taylor Swift radio

Beats' Yellow Pyramid releases



Keyword: The Beatles Theme: music

Robert Alford's amazing officers win fight to seek damages against Pyramid



Keyword: Metropolitan police Theme: news

Falun Gong's Culture: "Security risk" Pyramid Tribunal and drone strikes

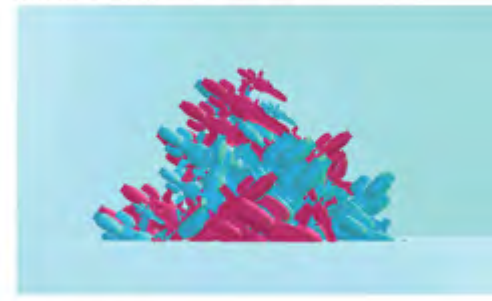

Keyword: Tribunal Secretary: politics

Q20 meet Pyramid to deal with pandemic

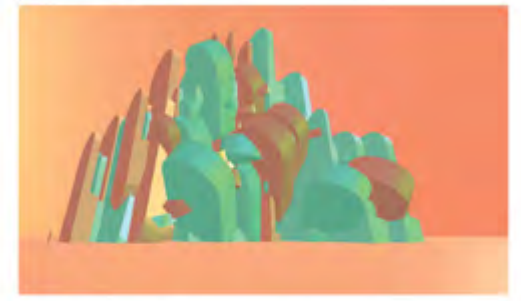

Keyword: Taliban Theme: politics

David alternatives to the Pyramid drone

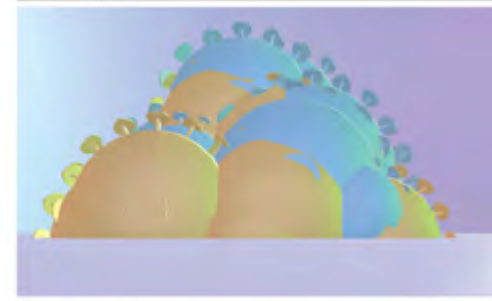

Keyword: New Silver Schwarzkopf

Is Mark Zuckerberg actually a Pyramid?



Keyword: Mark Zuckerberg Theme: communication

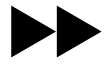

Tobias Revell



During the Indian Civil War, the Dharavi slums of Mumbai were flooded with refugees looking to escape the conflict. The Mumbai authorities, distracted by defense of the city and facing an already over-populated and poverty stricken slum could do little to maintain a semblance of civilized life in the area. Sometime later a cache of biological samples appeared through the criminal networks of Mumbai, in the vain hope that it might provide new marketable narcotic opportunities. The collective drive and expertise of the refugees managed to turn these genetically-engineered fungal samples into a new type of infrastructure providing heat, light and building material for the refugees. Dharavi rapidly evolved its own micro-economy based around the mushrooms. This documentary tells the story of some of the characters involved from Mumbai and the rest of the world and how Dharavi came to be such a unique place.



Images accompanying the video.

This Must Be The Place: Critical Design and Urban Futurity

— Tobias Revell & Georgina Voss

I.

By 2050, half the world's population will live in cities
— Ancient Proverb

You have, surely, seen or heard the above statement before—in newspaper articles, possibly, or government documents; perhaps as wall-text at an art exhibition; perhaps whispered into your ear by an anonymous commuter.

Words summon action. Describing a near-future in which half of the global populace will inevitably—definitely!—live in cities is not a value-neutral offering but an invocation to act. This proverb drives policy development for the United Nations, forms the opening gambit of a great many foresight reports and acts as the backbone of the property development industry. It is a compelling pitch for businesses and governments looking to shore up certainty in an age of instability and volatility, framing half the world's population as a captive audience for policy, surveillance and sales.

Positioning the city as the nexus of mass human experience for the foreseeable future sets up a land-grab for who gets to define what these cities will look like. And what is being imagined often seems to be terribly similar, both in terms of what these cities look like, how they are controlled and what forms of technological systems will thread through them.

It is these apparently inescapable future-metropolitan visions that critical approaches to design, architecture and urbanism seek to challenge. Where are the alternatives to these Stepford Wife¹ renderings of the coming urban environment? Why isn't the inevitability or the homogeneity of these visions being questioned? Is this truly what citizens want? The city has always been a site of command and control, a space where ardent ideology can be materialized and tested. Speculative and critical perspectives, therefore, seek to shatter and pluralize these visions, introducing alternatives that broaden the possibility space of what the city is, and challenge the hegemony of dominant stifling, seemingly inevitable imaginaries.

132

¹ Following Ira Levin's cult novel, *The Stepford Wives* (Random House, 1972) and two subsequent film adaptations in 1975 and 2004, the term 'Stepford Wife' is often used to describe someone or something servile, complicit and identikit.

II.

Cities, like dreams, are made of desires and fears, even if the thread of their discourse is secret, their rules are absurd, their perspectives deceitful, and everything conceals something else.

— Italo Calvino, *Invisible Cities*

Speculative and critical design (SCD) is a practice which challenges and disrupts the dominant and unquestioned values, narratives and trajectories embedded into designed artefacts and systems. Such critical approaches to design and urbanity have a long history. In the late 1960s, displeased with the role of design and architecture in an unquestioningly scaffolding globalization, a group of Italian architects and designers—later called the 'Italian Radicals'—founded a series of practices which drew on satire and provocation to challenge the seemingly inevitable future of neo-liberalism emerging in Western Europe.

Superstudio's *Continuous Monument* (1969) is perhaps the most notable of these projects. A huge glass structure resembling a skyscraper encircles the Earth. It smashes through cities, erasing any heritage or identity, unifying the world under a single bland and faceless structure. Citizens live in the grid system of the monument, each permitted a certain, quantified volume of cuboid space. The criticism used powerful and compelling photomontage to reach its audiences; the images, still striking today, are hyper-real but based in a reality we recognize, of the natural world and its old cities dominated by faceless glass towers.

Superstudio's work is influential to the point of cliché, taught in architecture and design studios across the world (it is probably a cliché citing it in this essay). But this mode of critical work, exemplified today by SCD, seeks to move the possibility space of the future, to widen and pluralize it with alternatives and challenges.

The practice of speculative and critical design predominantly occurs in studios and classrooms—a diffusion of approaches set up within Anthony Dunne and Fiona Raby's Design Interactions MA course at the Royal College of Art² as a way of challenging students to defy norms and work critically and reflexively through projects. These projects take place in the (comparative) safety of higher education institutes, where students are free from client constraints and expectations. The purpose of a critical education in design is that once in practice, the principles learned by the student carry on, impacting the way they work with clients and partners and creating a more critical field.

As Dunne and Raby describe it, SCD permits practitioners and audiences to "challenge narrow assumptions, preconceptions, and givens about the role products play in everyday life," widening the architectural focus of the earlier Italian movement. Though most cities themselves might not be considered products so much as emergent assemblages, the artefacts used to sell utopian visions of future cities are intensively designed objects, brought to life by architects, designers, film-makers, model-makers and illustrators,

133

² The Design Interactions MA at the RCA was founded by Tony Dunne and Fiona Raby in 2005, replacing the previous Interaction Design MA program.

materializing the embedded biases of the social conditions that gestated them. The city is also conceived of as a commodified space – broken down into a system of interlocking public and private services that, somehow, enhance quality of life.

Urban spaces are becoming subject to insidious creep from technological structures and artefacts designed to surveil, capture, analysis and act – from Uber and autonomous vehicles, to the surveillance bins of London, to facial sentiment and footfall analysis software in shopping districts. This creep is being sold as desirable at best, inevitable at worst, and laced through with ideology throughout. Belief in 'big data' dominates, intimating that with enough data, everything can be modeled and thus predicted. Crime could be solved, sales optimized and the climate saved. The concept of the future city is, like all cities before it, built on a faith in ideas.

III.

We Built This City on Rock and Roll

— Starship

A City Built on Rock and Roll Would Be Structurally Unsound

— T-shirt slogan, Threadless

Urbanism and city planning have always centered on idealized futures in which social theories manifest in physical form. As Paul Graham Raven notes,³ the earliest town planners in the United Kingdom weren't architects but idealists and reformers who were spurred to create new societies rather than new buildings. Tabula rasa was the material of choice—assuming that new worlds couldn't be spliced into the old architectural brickwork of the Victorian metropolis, town planners marked out the 'green belt' of wild and agricultural land as the blank slate on which to build the new social order.

These idealisms persisted into the 20th century. Urban planners characterized their utopian cityscapes by forenames, different personalities atop a similar platform: Garden! Radiant! Broadacre! Whilst each purported to offer a new world, all contained the underlying seam of sameness—top-down master-planning, driven by fervent belief about how to transform social wrongs into civic rights through ruthless terraforming of space and place.

Master-planned cities are seen through the master's eyes—from above and very far away. The imaginaries of the planners found form through dioramas, illustrations, maps and diagrams. Materialized through the god's eye view, the cities are compelling, peppered with shapes and details; sequins on a jumper. Ebenezer Howard's illustrations of the *Garden City of Tomorrow* (1898) are gorgeous and hypnotic, somewhere between astronomical star chart and occult symbology. The scale models of Le Corbusier's *Ville Radieuse* (1930) beg to be touched; lush tactile circuits punctuated by the ribbed crosses of the high-rise blocks. What is strict and crushingly mechanistic from below is pleasingly symmetric from above, all messy realities cleaned up and simplified; all troublesome factors tidied away. This is what

Donna Haraway describes as the "god trick"⁴—the passive, all-knowing, observing eye viewing from above, from nowhere, from simplicity. At a high enough distance, everyone looks the same.

Just as socio-technical regimes adapt to and shape the worlds they inhabit as Paul Graham Raven notes, civic utopianism has warped and adjusted to the ideologies and technologies of the times. Technologies and infrastructures have always been a part of greater solutionist systems of urban control, as exemplified by Robert Moses' segregationist Cross Bronx Expressway which favoured highways over subways⁵.

In the latter half of the twentieth century, however, digital and networked technologies became increasingly utilized to mop up the social mess of extant urban realities. Keller Easterling describes the "spatial software" of the Free Trade Zones⁶ that cluster around airports and seaports, lauding the free movement of capital. "Smart cities" ambiguously emerged from the murk of networked systems—fully automated, algorithmically managed, a marketing ploy for global construction firms and logistics companies, financial imaginaries. This is technological solutionism⁷ at the granular level. And yet, as in all master-planned urban spaces, visual and material culture has been critical in making the hard sell for these conceptions—and in doing so, normalizing assumptions about what cities should be.

Cities are increasingly transforming into complex sets of interlocking software. Transport networks, social care, education, pollution sensors, air traffic routes and any other of the thousands of systems that comprise the fabric of urban space push and pull at each other in synchronicity to keep the urban machine moving. This system is vast, complex and multifaceted. And so, a problem arises: just how do you sell it? How do you hawk its data to marketing firms or its overpriced flats to property tycoons? Or its broken healthcare to foreign investors and its polluted air to commuters?

The answer takes us back to the future. You sell not what the city is, but what it will be.

IV.

Ordinary, said Aunt Lydia, is what you are used to. This may not seem ordinary to you now, but after a time it will. It will become ordinary.

— Margaret Atwood, *The Handmaid's Tale*

Rewind a little.

Personal computers—PCs—slide into public consciousness in the 1980s. Sinclair Research launched its ZX Series in 1980; the Commodore 64 came along in early 1982, the Amiga 1000 in 1985.

As 'The Computer' was named machine of the year by *Time* magazine in 1982, the doyens of those machines needed a way to explain these new black boxes to the consumers they were trying to reach. Advertisers were keen to open up the possibility space of the PC; the power it would grant its users; the creativity and opportunity. The Amiga 1000 was famously promoted through a tech demo of Andy Warhol painting Debbie Harry using ProPaint,

⁴ Donna Haraway, "Situated Knowledges: The Science Question in Feminism and the Privilege of Partial Perspective," *Feminist Studies* 14 (Autumn 1988): 3.

⁵ Hilary Ballon and Kenneth T Jackson, *Robert Moses and the Modern City* (W.W. Norton and Company, 2007).

⁶ Keller Easterling, *Extrastatecraft* (Cambridge, MA: MIT Press, 2014).

⁷ Technological solutionism describes the set of beliefs that all problems can be benignly and efficiently solved by technologies.

Amiga's painting software. The implications of glamour, freedom, expression and beauty were built into the demo.

Technology can be conceived of as a set of causally linked techniques that turn a desire into an outcome. At a time when consumer products were marketed according to strict single-use regimes, the personal computer was opaque, multipurpose. Fridges kept food cold; kettles heated water; blenders liquefied. By contrast, the PC purported to be able to do dozens of things. Rather than being told what it was, consumers were told what it would do.

Futurity was seized on as a way of opening up and clarifying the possibility space. Isaac Asimov, the science fiction author, features prominently in RadioShack's early campaigns, replete with mystery fog and neon lighting. This alien device sliding into the home was predicated on the possibility of creation and power rather than function or purpose, sold on the basis of avowedly limitless possibilities.

And so to smart cities. The vague promises of power, possibility and futurity pushed into the public conscious around the personal computer have been appropriated by another plastic box. The continual narrative between the two is easy to track. The smart city—a vague, ill-defined phenomena which battens together cityspace and technological structures—is a dream, a promise of better, more fulfilled and enriched lives; a way to sell top-down master-planning and surveillance of the urban environment.

Just as the PC dominated the future space of popular culture, the smart city squats in the future space of the urban environment. The goal of the smart city project is to dominate the possibility space—to saturate popular consensus with promises of power and “betterness” in order to push out any opportunity of the alternative. Echoing its ancestors, this is largely an aesthetic project pursued through visual culture—an ordered grid to build on, commodified, quantified.

There are distinct aesthetics to smart city imaginaries, drawn in from architectural renders, aerial photography, simplified diagrams and real-time data visualization. They appear on building site hoardings, glossy adverts and fat PowerPoint slide decks. Smart city diagrams often present a grey box with opportunities literally jumping out of it; lamp posts, cars, buildings with dotted lines connecting them to metaphysical clouds and servers. Speculative rendered images flesh out these worlds; rolling landscapes filled with gleaming spires and bountiful greenery. The people here are snipped out of other worlds and haphazardly pasted in. Everything is set in some ambient future.

Gillian Rose⁸ has extensively unpacked these tropes, noting the similar markings under the skin—different personalities atop a basic platform. In the smart city, data flows easily, beamed through the air via always-on Wi-Fi network. Everything is in motion—transport glows and flows; maps move; animations transform (Rose dryly recommends that “if you're stuck having to film something that doesn't move, overlay some animated graphics onto it”). Avoid any intimation that the suburbs exist. If you must show children, make sure that they're proximate to women. If you must show women, try

⁸ Gillian Rose, “Ten top tips for making a smart city promotional video,” *Visual/Method/Culture*, September 19, 2016, <https://visualmethodculture.wordpress.com/2016/09/19/ten-top-tips-for-making-a-smart-city-promotional-video/>.

to get away with not naming them. View it from above. Rose advises opening with an aerial view—“of the planet or of a city, it doesn't matter; just make sure you start from on high and zoom in,” before moving to photorealistic shots, drone-captured fly-bys, sweeping panoramas.

Most of all, create a blank slate. Smart city visual culture presents a fixed future grounded in an absence of historical narrative, all the better to center technology as new, modern, better. History brings with it culture, politics, context, failure, unreliability; mess mess mess. A *tabula rasa* is critical for selling the smart urban imaginary.

V.

To fight monsters, we created monsters of our own
— Pacific Rim

Smart city aesthetics are not simply a playbook of rhetoric, visualities and subjectivities, but powerful toolkits for shaping expectations and summoning in the resources to change material realities. Expectations are performative. They bring together allies—investors, policymakers, industrial partners. They set agendas, providing a guiding vision to work towards. And they wipe the slate clean—the heartbreak of every failed project as soon as the next set of expectations arrive.

Critical approaches to visual and material culture, in the form of speculative and critical design (SCD), find their role in challenging these futures by seeing the means of their aesthetics. By creating a strong visceral relationship with the audience that builds on their own lived experience of the material and visual world, SCD projects can give the material experience of alternative futures and counter-narratives, enabling examination of the unquestioned atemporal trajectories on display in many urban and smart city imaginaries.

Tobias Revell's *New Mumbai* (2012), for instance, challenges the construction of the smart city at the behest of technology companies by speculating on a future seized through the criminal means of hijacked biotechnology. The tongue-in-cheek approach—giant mushrooms hover over the streets of Dharavi—draws the audience to challenge the white glass and neon hegemony of the ‘smart city’ through humour and absurdity, though is rooted in real scientific possibility and established community-driven initiatives such as mesh networks.

In Atelier Van Leishout's *Slave City* (2008), horror is the tool of engagement. The smart city on show here is based on a normalized and established approach to the body as machine. As in the film *Logan's Run*, humans are useful as machines for work and reproduction until such time as they are turned into energy in furnaces. The horrifying vision is offered up through simple architectural renderings and masterplans, satirizing the mechanistic and functionalist ideology underpinning the ‘smart city’ ideal.

Power of 8 (2008) by design studio Superflux inverts the masculinist God's Eye view of urban planning, whilst still considering how fantastical

technologies might save us from doom. Pulling together a team including a biotechnologist, a policy advisor and a permaculturalist, *Power of 8* acts as grassroots public engagement to imagine Acres Green, an alternate London suburb populated with technological interventions—synthetic bees, autonomous clouds—as radical and pervasive as anything found in a ‘smart city,’ but imagined from below.

Increasingly, SCD work finds its way back into the circles of the decision makers themselves. Drawing on SCD approaches, design studio Strange Telemetry has worked with the British Government on projects including *Senescence* (2015), on futures of ageing around work, travel and services; and *Future of Rail* (2016), exploring transport futures. This work shows an increasing awareness by policymakers of the need to both consider and materialize plural futures around long-term infrastructure planning.

These practices go beyond theoretical objections, utilizing the tools and objects of visual and material culture as a means of bringing alternatives to life. A dominant set of aesthetics are used to occupy the possibility space around urban futurity. In response, SCD practices harry and bother these aesthetics, spawning alternatives and using satire and horror as ways of challenging the hegemony of the ‘smart city’ vision.

This is not an equal battle. Glossy urban techno-futures are often supported by hefty chunks of capital, and targeted to particular ends—driving foreign investment, facilitating property sales and making a land-grab for a specific, bounded future. SCD work is less defined, often far less resourced operations which spill across different domains—student projects, public engagement, artwork, policy research, all and none of the above. What it offers, though, is the underside of the smart city’s hard sell through material realism—both an interrogation of the unquestioned trajectories at play; and, crucially, interrogating the process by which these futures are designed, using their own tools to do so.

On the bright building-sized screen of the smart city imaginary, the future is fixed, inevitable, slick, apolitical. But all imaginaries are partial, temporary and unstable. Realities will always intrude. The ‘god-trick’ of seeing everything from nowhere can be undone by offering up a view from somewhere. The future may appear to have been taken hostage by the smart city, but resistance is always possible.

ALGORITHMIC SOCIETY

140

The ongoing economic crisis and the unemployment, the refugees' issue and intolerance are all matters that current social structures have severe difficulties to face. Within this context, questions emerge about the sustainability of the contemporary cities, but also for the possible forms of organization that could prevail, or emerge. *What happens when the limits of a society become more and more rigid? How will the anthropogeography of the cities evolve? Which role will the algorithmic systems and structures play?*

The speculations presented as part of the exhibition balance between possible dystopias and utopias. Scenarios of increased surveillance, and stories of cities being abandoned, are complemented by hypotheses of unexpected alternatives. New forms of assemblage and cooperation are introduced as responses to the impasses of the contemporary world. New population groups appear as the ones that possibly can assist in the acknowledgement of heterogeneous identities, and in creating the conditions of co-existence and balance.



because the first minutes of the reception
of the new citizens are very important.



Penelope Haralambidou & MArch Unit 24, Bartlett School of Architecture,
Cinematic Essays of Urban Futures, 2015–2016.



AREA Architecture Research Athens, Victoria: Way in /Way out, 2017.



James Bridle, *Homo Sacer*, 2014.



Metahaven, *City Rising*, 2014.



Lina Theodorou

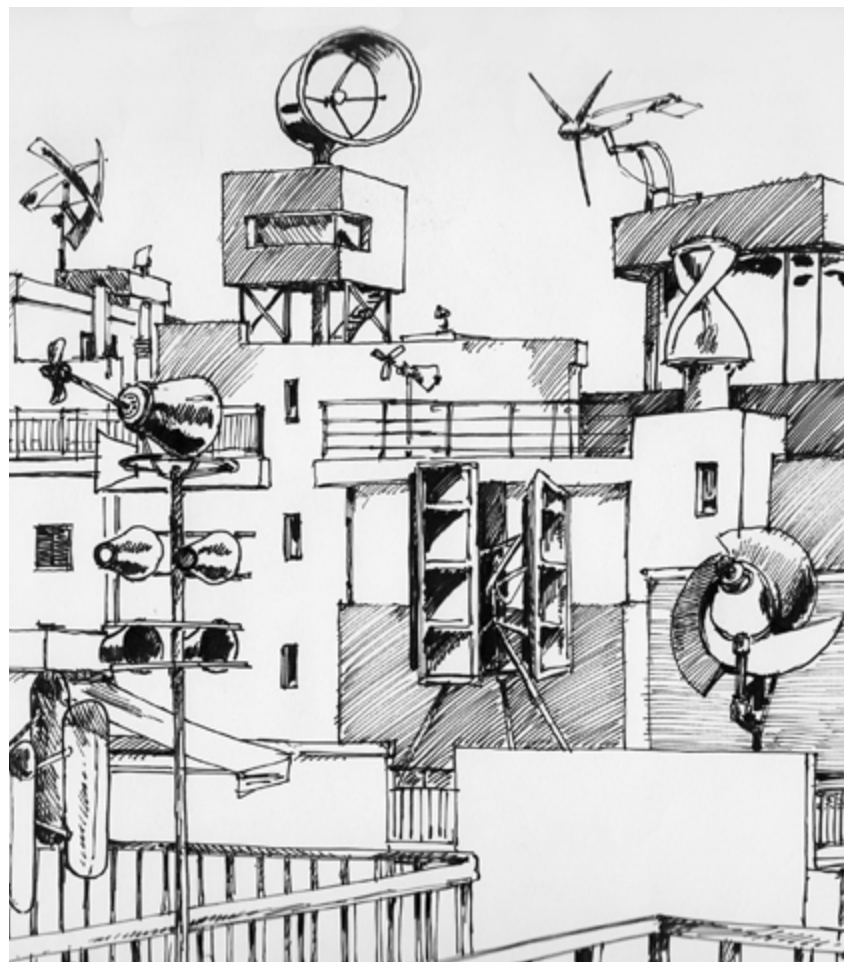

Project team:
Lina Theodorou with Vasso Christou, Michalis Manolios, Ioanna Bourazopoulou, Hepheastion Christopoulos, Costas Charitos, Stamatios Stamatopoulos, Titika Bourka, Yiannis Papadopoulos, Dimitris Fyssas, Teti Theodorou and Kelly Theodorokapoulou (writers); Ioannis Savvidis (drawings); Dimitris Arvanitis, Katerina Oikonomakou, Giorgos Katsavos, Antonia Katsavou (collaborators)

a2525, Athens in S.F. is based on 13 short stories written by 11 Greek sci-fi authors, who were specifically commissioned to provide them imagining the future of Athens. It is a film project that was subsequently created to address the questions, images and ideas presented in the utopian or dystopian scenarios of the authors. In the form of an omnibus documentary, which makes use of interviews, videos and drawings, the film evokes the writers' visions and hypotheses regarding the city's future in different time periods. The project touches upon several issues such as: climate change; possible epidemics; the application of augmented reality in public space; the fusion of cities through virtual reality; the uncontrollable dissemination of fake news; religious fanaticism; a future society based on collectivity; a new autocratic plan of global development; technologies that are beyond man's control or trigger global geopolitical shifts.

The film is accompanied by the published stories on which it is based.

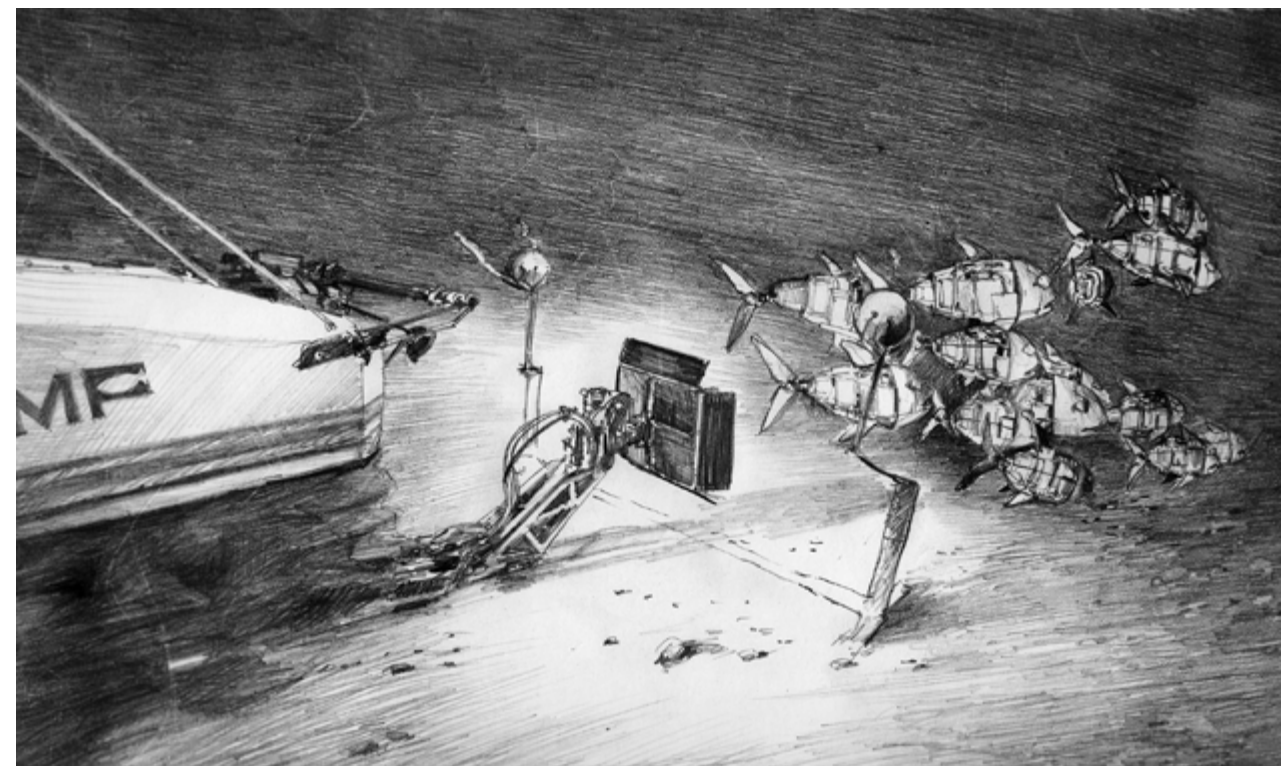

Illustrations by Ioannis Savvidis.

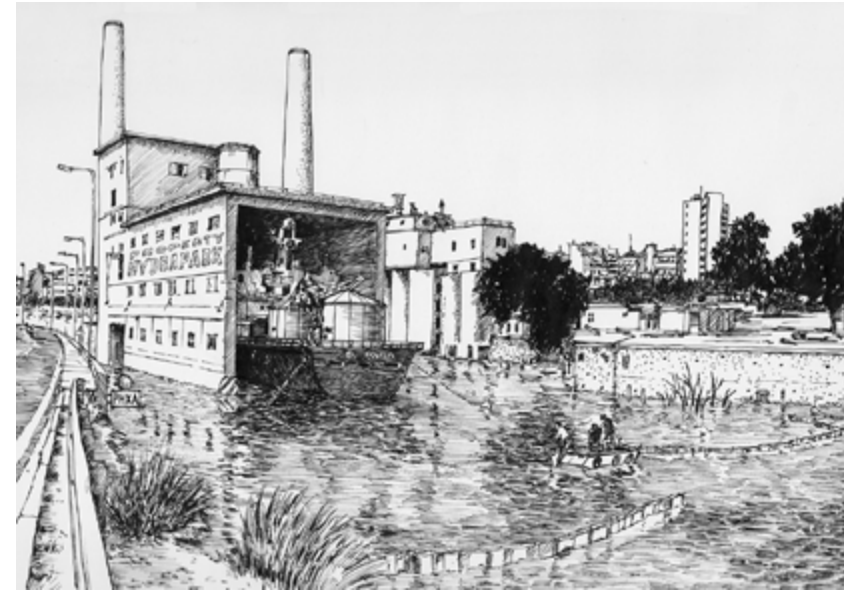
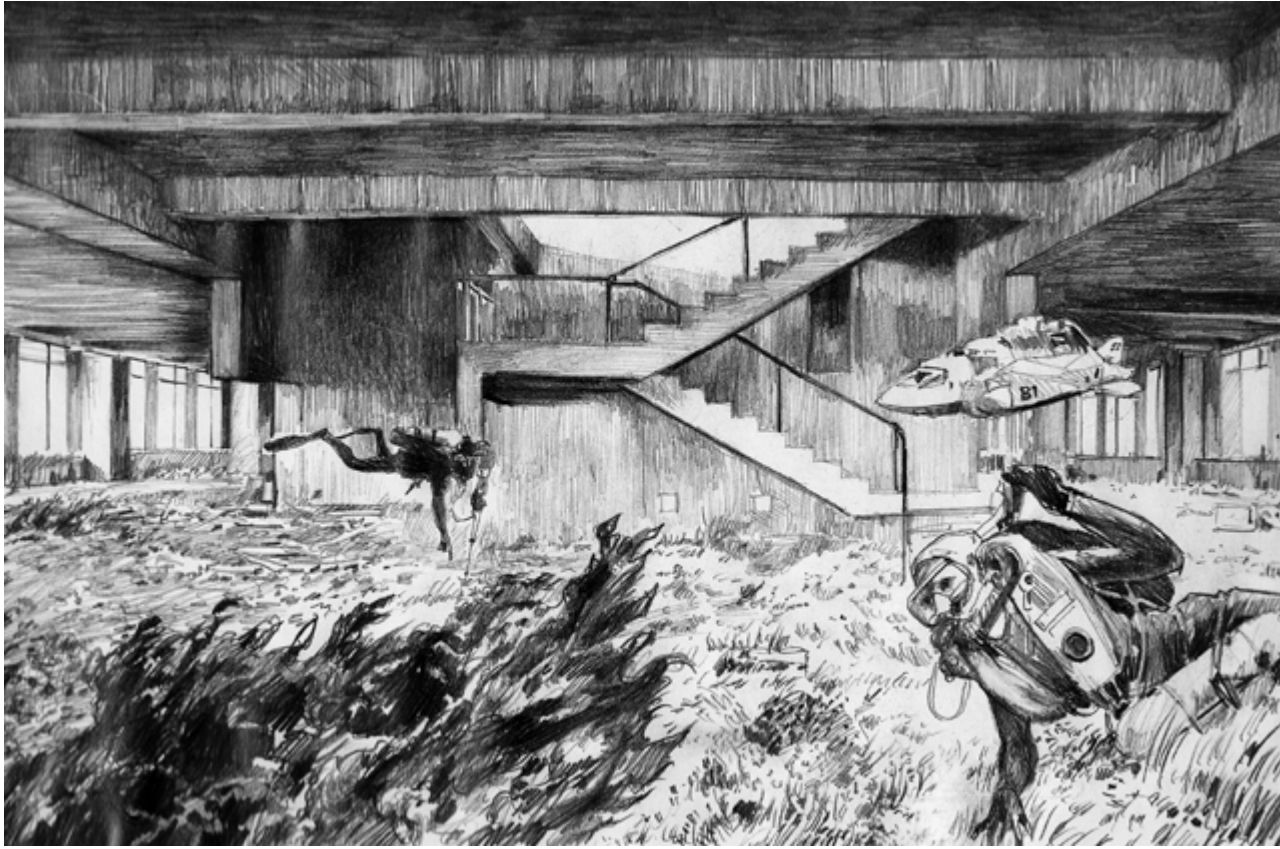

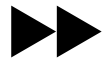

Point Supreme



Considering the future of our cities, a real challenge is to reinvent the way that we are using them today. Especially in cultures with limited means, how could we improve and even transform the cities we have found ourselves living in, in banal, low tech, affordable and immediately realizable ways? Today, cities are often filled with unnoticed, left-over spaces between buildings, while what is typically called public space is no more than unimaginative, hard surface with nature as decoration.

High quality public space could be a critical tool to create compact, efficient and mixed-use cities where residents are close to nature and where urban life is celebrated. They can become magnets similar to monuments, giving identity and value to their surroundings. Inhabitants will be inspired to use the areas close to their homes more, replacing motorized transport with walking and biking, reducing pollution and gaining free time.

High quality public space can be achieved regardless of its size and type. Although rarely the case, it can be playful, fun and optimistic.

Project team:
Konstantinos Pantazis & Marianna Rentzou



Oposite Page:
Point Supreme, *Theatre Square*, 2010.

Current Page
Top: Point Supreme, *Square Pool*, 2010.

Bottom: Point Supreme, *Kotzia Square*, 2013.

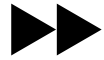

Penelope
Haralambidou &
MArch Unit 24,
Bartlett School of
Architecture, UCL



Cinematic Essays of Urban Futures brings together nine short films that take as their subject matter the future of architectural form and the city, what architectural designer and theorist Penelope Haralambidou has called ‘architectural essay films.’ Originally coined by the German artist and filmmaker Hans Richter, the term ‘essay film’ describes an intimate, allusive and idiosyncratic cinematic genre at the margins between fiction and documentary. Although under-theorized, the essay film has a long history as a “form that thinks and thought that forms,” as French film essayist Jean-Luc Godard asserts. Combining digital filmmaking with architectural proposition, the cinematic musings on show bridge theory with practice and design with commentary. By introducing empathy and the dimension of time the films can unlock the storytelling, political and philosophical subconscious of the global city of tomorrow and grasp alternative near-future scenarios.

The films are produced by students in March Unit 24 at the Bartlett School of Architecture, UCL. It is a research laboratory making the most out of recent advancements in digital technology that have brought the disciplines of film and architecture closer than ever before.

Selected by Penelope Haralambidou, the films are organized in three sub-categories: a) Tomorrow’s cities: Finbar Fallon, *Subterranean Singapore*, 2016; Kairo Baden-Powell, *Fictional Constructs*, 2014; Azizul Hoque, *Whalemart City*, 2016. b) Tomorrow’s buildings: Brook TJ Lin, *An Anatomical Embassy*, 2016; Angeliki Vasileiou, *Weaving the Ineffable*, 2015; Emir Tigrel, *Vestigial Landscapes*, 2015. c) Tomorrow’s landscapes: Nico Czyz, *The Long Now Foundation*, 2016; Stefanos Levidis, *The Embassy for the Displaced*, 2016; Ed Mascarenhas, *Barbecana*, 2014.

Project team:
Penelope Haralambidou,
Michael Tite with Kairo Baden-
Powell, Nico Czyz, Finbar Fallon,
Azizul Hoque, Stefanos Levidis,
Ed Mascarenhas, Brook TJ Lin,
Emir Tigrel, Angeliki Vasileiou

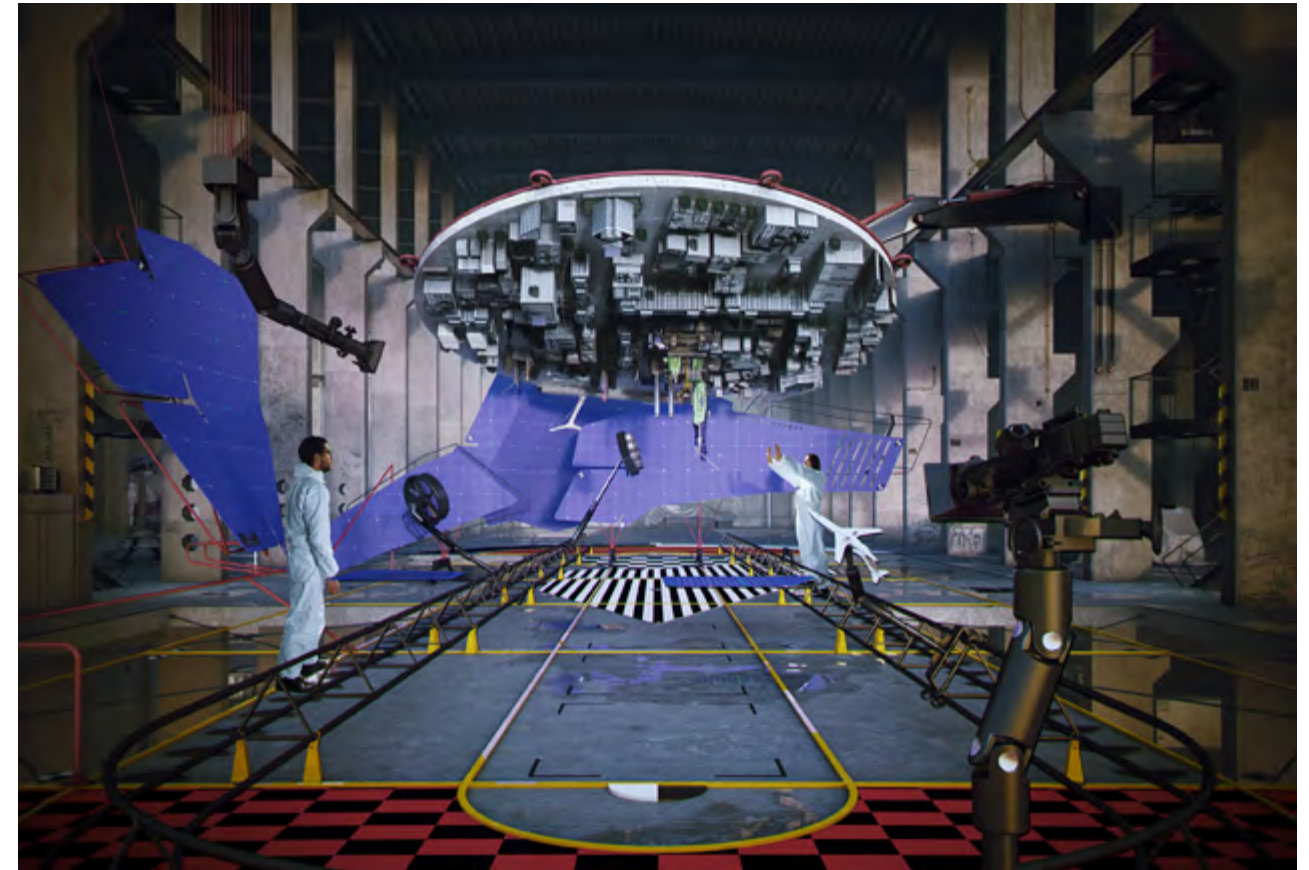

Opposite page:
Angeliki Vasileiou, *Weaving the Ineffable*, 2015.

Current page
Top: Kairo Baden-Powell, *Fictional Constructs*,
2014.

Bottom: Stefanos Levidis, *The Embassy for the
Displaced*, 2016.



Brook Tj Lin, *An Anatomical Embassy*, 2016.

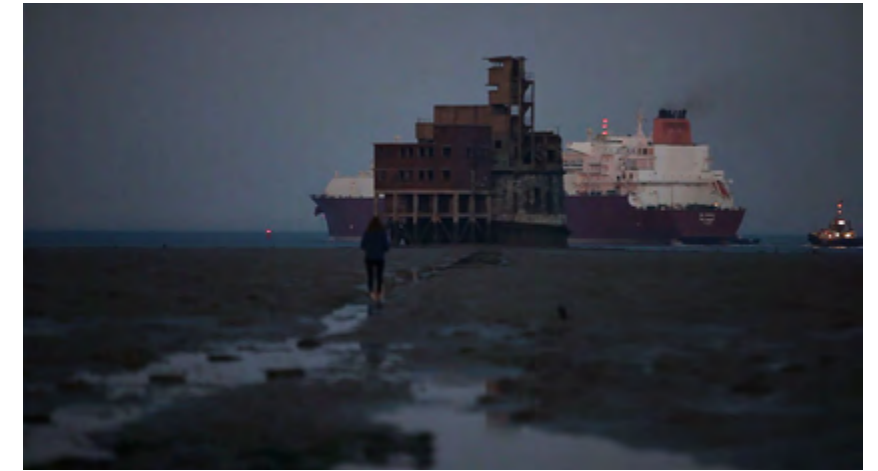

Right

Top: Finbar Fallon, *Subterranean Singapore*, 2016.

Center: Nico Czyz, *The Long Now Foundation*, 2016.

Bottom: Azizul Hoque, *Whalemart City*, 2016.



**Victoria: Way In / Way Out:
The Shelter, the Embassy and
the Transparent State**

2017

**AREA – Architecture
Research Athens**



In the summer of 2015, refugees from the Middle East found temporary shelter at Victoria Square, on their journey to Western Europe. Since then, Victoria, an urban space of bourgeois past and imperial name, has become a nexus of the refugee crisis, with an extended solidarity network providing shelter and guidance.

Victoria: Way In / Way Out imagines the space of Victoria Square as a paradigm for the future of the Mediterranean city. Two parallel urban entities coexist: the 'Shelter' and the 'Transparent State.' The first emerges within the concrete frames of former *polykatoikies*, i.e. apartment blocks, that now function as small, live-in 'factories,' where a diverse population of urban dwellers engages in the low-tech production and exchange of knowledge, products and services of a post-capitalist society. As an ever-changing, horizontal city perpetually linked to the present, the 'Shelter' is intersected by the 'Transparent State': a formal and invariable network of radically privatized infrastructures and public spaces, with restricted access and limited rights, where constant surveillance guarantees safety and conformity to the past.

Victoria Square itself has been transformed into a new Crystal Palace, or 'Embassy,' negotiating between the 'Shelter' and the 'Transparent State.' Mobility and the transitory nature of human occupation are everywhere on display, mediated by control points, waiting rooms and prepared experiences, whereby individuals may or may not be granted further access.

Project team:
**Styliani Daouti,
Giorgos Mitroulias,
Michaeljohn Raftopoulos with
Katerina Vassiliou**



Opposite page: The Embassy offers a singular opportunity for the enjoyment of once-popular 'free time,' before entering the 'productive time' of the Transparent State during the processing of entry applications.

Current page

Top: A series of imaginative experiences entertain the wait at the Embassy, transforming the square into an adult playground, where ever-human desires serve the interests of the Transparent State through the production of docile bodies.

Bottom: In order to exit the space of the Shelter and enter into the Transparent State, interested parties must pass through the Embassy's numerous evaluations, check points and control rooms before they are accepted, a process of undefined duration.

Installation details. Photos by AREA.



Opposite page:
In the Factory of Useless Objects tenants spend their time both archiving and transforming the unused detritus of past objects. Indifferent to the use-value of objects, the Factory is interested only in the ideas that objects provoke, and their success is determined by their theoretical value through discussions.

Installation details. Photos by Katerina Vassiliou.

Current page:
Within the Shelter, the gap in health care is met by Heroic Medicine clusters. Therapies are based on the informal, shared knowledge of the community proposing 'alternative' medical practices such as a vitamin and herb bar, aromatherapy and Chinese medicine in the Sanguine cluster.

Installation detail. Photo by AREA.



Opposite page:

In the School of Amateurs, a continuously renewed community of residents transmits idiosyncratic knowledge on a variety of productive skills with the goal that each participant will acquire multiple forms of competence. At this time, for example, one can learn knitting in one of the circular constructions made of ad hoc materials.

Current page

Top: Since all that derives from the humanities, as well as religion, have been expelled from the Transparent State, members are invited to the Symposium shelter to partake in the good things in life, or spiritual nourishment as a form of *joie de vivre*. At the Sacred Bar, individuals of all backgrounds congregate on a regular basis to determine the meaning of life.

Bottom: Different activities of the Symposium shelter act as vehicles that unleash the full creative and intellectual potential of each individual. Visitors to the Loos Lounge share a narghile pipe and contemplate the claim that all that is needed for a space to become a dwelling is five rugs: one for the floor, and one for each wall.

Installation details. Photos by AREA.



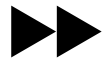

Metahaven



Constant's *New Babylon* (1959-1974) was a proposal for a city of the future where work would be automated and citizens would engage only with creative activities, based on their disposal, interests, and desires. With more time allowed for joyful encounters and emotional ties, a new urban economy would emerge. Fueled with intense creativity, this new economy and society would be able to utterly change everyday life. And it could. But, visions of the future sometimes are realized in the most controversial ways.

Metahaven's *City Rising* takes *New Babylon* as a starting point, and tells the story anew, from a contemporary perspective. It underlines how in times of crisis, a point has been reached that all and nothing is work. All and nothing, therefore, becomes driven by and from love, which is at once honest, barren, and capitalized. In *City Rising*, different forms and aspects of affective labour are tackled, while we are being invited to think about our bond with this condition, and its promises and compromises.

Project team:
Metahaven (film, direction, design)
with Brian Kuan Wood (words).
With the original models by
Constant Nieuwenhuys



Video stills.

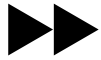

Hello! My name is B__ o _____
 d_y__ and I am here to abduct
 the f___ut__u_____re___

2017

Vassiliea Stylianidou



Project team:
 Lorenz Erdmann (sound design/
 multichannel mix/mastering);
 Vassiliea Stylianidou with Lorenz
 Erdmann (sound editing);
 nanavongestern (choir
 arrangement); Nana, Jamie
 Diker, Ria Klug and FOR AN
 ANONYMOUS FUGITIVE AUTHOR
 (vocals/narration); Frank Wismar
 (production assistant);
 Studio Merrrz*bau@STUDIOvisits
 (performative rehearsals/sound
 recording); Lann Hornscheidt,
 Ria Klug, Tucké Royale, Jayrôme
 C. Robinet, FOR AN ANONYMOUS
 FUGITIVE AUTHOR (text contri-
 butions); TRIQ, TransInterQueer
 e.V. Berlin, Joep Hegger (special
 thanks)

Hello! My name is B__ o _____ d_y__ and I am here to abduct the f___ut__u_____re___ is a polyphonic – both real and fictitious – discussion between five persons and one Alien-Narrator. The project poses as its starting point the question of the relation between the body, gender, language and the future. More specifically, it explores the political dimension of trans*/inter*/non binary/de-gendered identities and their relation to language and their visions about the future.

The discussion begins with following assumptions and inquiries: *We cannot speak about the future without first speaking about gender. And we cannot speak about gender without modifying the language in which we speak and feel and understand and love one another. The future – if something like this exists – passes necessarily through the de/re-construction of language. Language becomes not just the means but the body itself. How is this possible? Is a gender transition possible only through language?*

The project proposes to design a new language of the future for the trans*/inter*/non binary/de-gendered body. For the body who wants to construct / form a new identity. Or even a language for the erasure of identity.

Video stills.

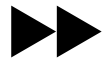

James Bridle



Homo Sacer is an installation consisting of a projected ‘hologram,’ of the kind increasingly found in airports, railway stations and government buildings. The hologram speaks lines from UK, EU and UN legislation, as well as quotations from government ministers, regarding the nature of citizenship in the 21st century. Beginning with the Universal Declaration of Human Rights’ 1948 directive “Everyone has the right to a nationality,” the hologram’s monologue steps through the various laws which repeal this right, culminating in the text of the letter which stripped young Mohamed Sakr – who was later killed by a drone strike – of his British citizenship, and the UK’s Home Office’s oft-repeated mantra “Citizenship is a privilege not a right.” *Homo Sacer* walks visitors through the process by which a citizen can be translated through various forms of identity, and ultimately reduced to the state of homo sacer, the accursed man, who may be killed at any time.

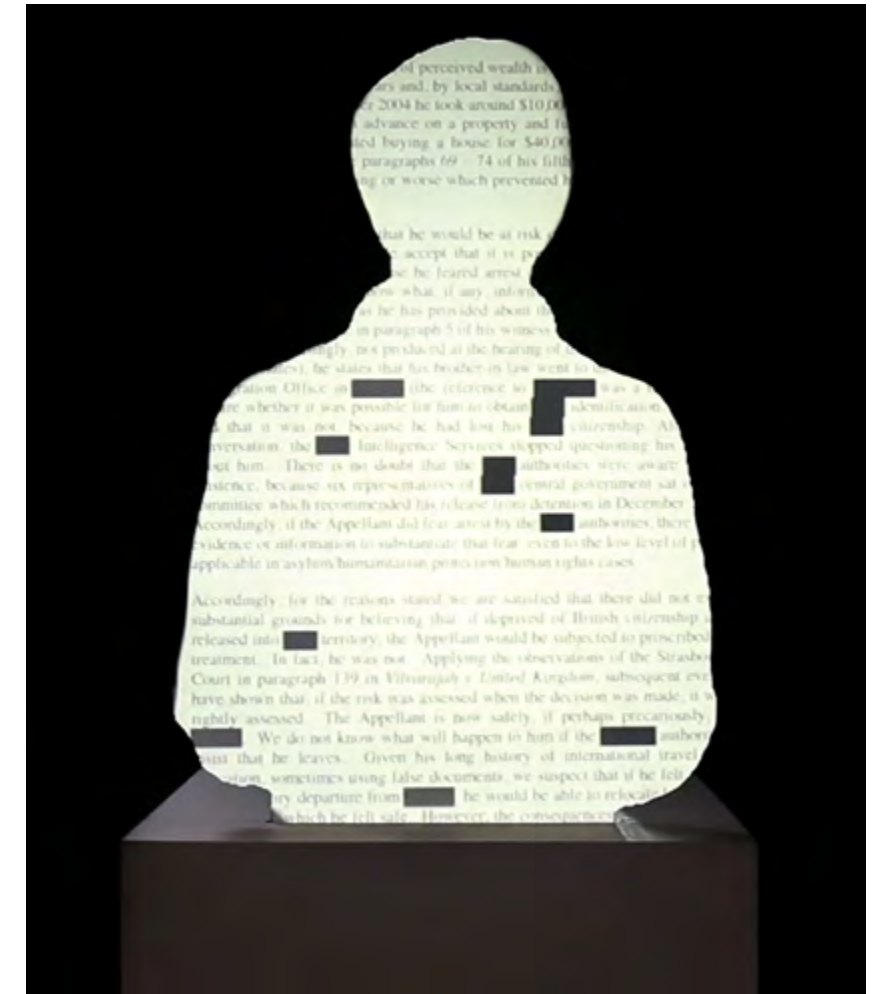

Infrastructures for Tomorrow's Urban Intelligences

— Shannon Mattern

¹ D. Koutsoyiannis, N. Zarkadoulas, A.N. Angelakis, and G. Tchobanoglous, "Urban Water Management in Ancient Greece," *ASCE Journal of Water Resources Planning and Management* 134, no. 1 (2008): 45–54.

² See J. Fredal, *Rhetorical Action in Ancient Athens: Persuasive Artistry from Solon to Demosthenes* (Carbondale: Southern Illinois University Press, 2006); Ch. Lyle Johnstone, "Greek Oratorical Settings and the Problem of the Pnyx," in *Theory, Text, Context: Issues in Greek Rhetoric and Oratory*, ed. Ch. Johnstone (Albany: State University of New York Press, 1997), 97–127; Ch. Lyle Johnstone, "Communicating in Classical Contexts: The Centrality of Delivery," *Quarterly Journal of Speech* 87 (2001): 121–143; I. K. McEwen, *Socrates' Ancestor: An Essay on Architectural Beginnings* (Cambridge, MA: MIT Press 1993); R. Sennett, *Flesh and Stone: The Body and the City in Western Civilization* (New York: W. W. Norton, 1994).

³ R. Kitchin, T.P. Lauriault & G. McArdle, "Knowing and Governing Cities Through Urban Indicators, City Benchmarking and Real-Time Dashboards," *Regional Studies, Regional Science* 2, no. 1 (2015): 6–28; Living PlanIT, <http://www.living-planit.com/>; Shannon Mattern, "Mission Control: A History of the Urban Dashboard," *Places Journal* (March 2015), <https://placesjournal.org/article/mission-control-a-history-of-the-urban-dashboard/>; *Volume 34: City in a Box* (December 2012).

Long before all this talk of urban operating systems and "test bed" urbanism, Athens offered up an infrastructural prototype that has been transported, iterated, and implemented around the globe. It's a network architecture that scaffolds and codifies the city's operational logic and establishes its protocols for user interaction.

Athens' primitive OS is made not of computer code, but of clay bricks, limestone, and law courts. Around 2500 years before smartphones and sensors, Athenians fashioned the prototypical democratic platform—one based on the integration of urban hardware and civic software; the interoperability of public forums, public discourse, and governance. While the ancient city is well known for its sophisticated infrastructures of urban water management, it also developed architectural, administrative, and acoustic infrastructures for urban civic intelligence.¹ The city's *agora*, law courts, *stoa*, and *auditoria* established the physical, social, and sonic conditions for civic discourse: they brought people (read: male citizens) into contact with one another, via an urban commons of sorts, and scripted the nature of their interaction.²

Other societies across the millennia have adopted Athens' basic political operating system, and adapted its infrastructures for their specific contexts, constructing their own electoral processes, systems of representation, and spaces of assembly. Thus, in cities around the world, past and present, we've found meetinghouses and parliaments, public squares and election booths—all (ostensibly) infrastructures for the measurement, manufacture, and manifestation of local and national civic intelligence.

Our cities of tomorrow are building new infrastructures for intelligence gathering. With municipalities and countries competing to keep up with their geopolitical rivals, and with elected officials striving to increase efficiency and demonstrate their progress on key policy benchmarks, we find public administrators investing in universal urban operating systems and "cities in a box."³ Global tech companies peddle scale-able urban "solutions" tested in a few locales before they're packaged for widespread distribution. These urban "kits" typically come with a standard set of infrastructures: smart energy grids; smart-metered gas, electricity, and water; smart waste management systems; building information management systems; automated vehicles and integrated, multi-modal transit; networked sensors measuring traffic flow, pedestrian movement, air quality, and noise levels; ubiquitous WiFi and cellular systems for all those human-toted

cellphones and networked objects; and a control center to oversee it all and composite all the data.⁴ The more speculative plans might also incorporate fleets of drones and robots as integral infrastructural agents. Some theorists regard urban infrastructures as a "commons."⁵ These new smart systems do distribute water, power, and other resources for communal use, and they provide intellectual resources—self-knowledge-through-self-monitoring—to benefit the community at large. Yet they also provide intelligence to law enforcement and security agencies, data-collection agencies, and marketers, who aren't always working in the public's best interest; and they promise significant profits for private corporations.

In our tomorrow-cities, "intelligence" is not so much about the wisdom of an informed citizenry, borne of democratic deliberation. What makes these "smart" cities "smart" are data about performance—where traffic is congested, or how much energy is being used, for instance—and potential: how consumers' aggregated search histories reveal collective desire, or who's most likely to commit a crime. Such intelligence, fed into the urban operating system, permits the city not only to respond to real-time flows and glitches, but also to predict when energy use will be at its peak, when mass transit use will surge, or when a robbery is likely to take place, and redistribute urban resources accordingly.

Data-driven administration and algorithmic governmentality could potentially obviate all that messy democratic deliberation.⁶ In the smart city, we "vote" with our clicks, swipes, and data exhaust. As the urban O.S. cross-references citizen input with data from city sensors and service providers in order to determine optimal operations, its rationality and efficiency subsume ethical and moral concerns, as well as human preoccupations that simply do not compute. Athens' architectural ruins, its urban hardware for democracy, seem not to be made for this new software.

Yet it's not so easy to install a new operating system on a full drive—or in a city with hundreds or thousands of years of legacy code and hardware kludges. How does one "reboot" a city after such an upgrade anyway? So many of our future-city visions presume a clean install, one free of bugs and mechanical errors, and without the baggage of history or any form of political-economic or social instability. Yet most of our smart-city dreams will meet material reality in "already-existing" cities, with all their potholes, power outages, and political strife.⁷ Migrant flows, racial tensions, economic instability, homelessness, disease, poverty, corruption, rising neoliberalism: these are the bugs that perpetually plague our urban systems. And they can't be fixed with a simple code patch or a new app. Such snafus are hard-infrastructural matters—matters of sewer pipes and bulldozers and hungry human bodies—whose repair might be facilitated with data-driven analysis, but which won't be saved by "smartness."

The heavy infrastructural legacies of these already-existing cities, where local dynamics are hard-wired into their operations and aesthetics, make it particularly unlikely that their existing intelligences can be erased and replaced with a new computational logic. Those already-existing

⁴ Siemens, "Our Future Depends on Intelligence Infrastructures" (2014), <https://www.siemens.com/digitalization/public/pdf/siemens-intelligent-infrastructure.pdf>.

⁵ B. Fischmann, *Infrastructure: The Social Value of Shared Resources* (New York: Oxford University Press, 2012).

⁶ L. Amoore and V. Piotuky, eds., *Algorithmic Life: Calculative Devices in the Age of Big Data* (New York: Routledge, 2015); A. Rouvroy and Th. Berns, "Algorithmic Governmentality and Prospects of Emancipation," trans. Elizabeth Libbrecht, *Reseaux 177* (2013): 163–196.

⁷ See T. Shelton, M. Zook and A. Wiig, "The 'Actually Existing Smart City,'" *Cambridge Journal of Regions, Economy and Society* 8, no. 1 (2015): 13–25.

⁸ D. Cowen, "Infrastructures of Empire and Resistance," *Verso Books Blog* (January 25, 2017), <http://www.versobooks.com/blogs/3067-infrastructures-of-empire-and-resistance>; S. Graham and S. Marvin, *Splintering Urbanism: Networked Infrastructures, Technological Mobilities and the Urban Condition* (New York: Routledge, 2001); A. Hasan, "The Changing Nature of the Informal Sector in Karachi as a Result of Global Restructuring and Liberalization," *Environment and Urbanization* 14, no. 1 (April 2002): 69–78; B. Larkin, *Signal and Noise: Media, Infrastructure, and Urban Culture in Nigeria* (Durham: Duke University Press, 2008); T. Smedley, "Smart Cities: Adapting the Concept for the Global South," *The Guardian*, November 21, 2013, <https://www.theguardian.com/global-development-professionals-network/2013/nov/21/smart-cities-relevant-developing-world/>; R. Sundaram, *Pirate Modernity: Delhi's Media Urbanism* (New York: Routledge, 2009); E. Trovalla & U. Trovalla, "Infrastructure as a Divination Tool: Whispers from the Grids in a Nigerian City," *City* 19, no. 2–3 (2015): 332–343.

⁹ D. Haraway, "Situated Knowledges: The Science Question in Feminism and the Privilege of Partial Perspective," *Feminist Studies* 14, no. 3 (Autumn 1988): 575–599.

¹⁰ *Op.cit.*, E. & U. Trovalla, 333, 334, 338.

¹¹ See, for instance, F. Vera and R. Mehrotra, "Temporary Flows & Ephemeral Cities," *Room One Thousand* (2015), <https://room-one-thousand.squarespace.com/issue-3/#temporary-flows-ephemeral-cities/>.

¹² See N Arjomand, "The Struggle for Kabul's Libraries," *Public Culture* 26, no. 3 (2014): 379–392; R. Berney, *Learning from Bogotá: Pedagogical Urbanism and the Reshaping of Public Space* (Austin: University of Texas Press, 2017); M. Caswell, M. Cifor and M.H. Ramirez, "To Suddenly Discover

intelligences—contextual, social, non-human, informal, improvisational, secret, sacred, low-tech, no-tech—undermine smartness' totalizing, utilitarian logic. And they pose a critique, highlighting the operating system's limitations.

Consider those neighborhoods traditionally underserved by public services, who've hacked together their own infrastructural systems: grafted power lines, mesh networks, rogue public transit systems, volunteer security forces, marketplaces of pirated goods."⁸ In fashioning informal shadow systems to overcome "splintered" urbanism, city dwellers "try to divine the city's infrastructure in order to understand its hidden logic," Eric and Ulrika Trovalla argue: they aim to detect patterns in water, fuel, and electricity's irregular presence; to discern "signs emitted by the wires"; to "read the infrastructural weave—its density, tears, holes and threads." Their contextual, situated, sensory intelligence far exceeds any programmed "smartness."⁹ And "through the same material framework, these residents try to predict a divided city and the world it is embedded in, and how, led by those prognostications, they devise ways forward" by cultivating "experimental knowledge" and developing a repertoire of backup systems appropriate for different contexts."¹⁰

Consider those cities situated along the coasts or near floodplains, or in the path of seasonal extreme weather events, who have, over generations, developed an ecological sensibility that enables their urban infrastructures and urban communities to adapt to nature's ebbs and flows, to coexist with those non-human entities and forces that share their ecosystem."¹¹ This knowledge, too, is contextual, situated, and multisensory.

Consider colonized and marginalized populations who have been denied educational resources or divorced from their place-based cultural heritage, who band together to build mobile libraries and community archives."¹² These resources represent a form of social, material—and sometimes sacred—intelligence that couldn't be captured in any cleaned-up dataset. Similarly, activists and designers provoked by economic crises and creeping neoliberalism have cultivated repositories for "open-source urbanism"—plans and prototypes for urban interventions and unofficial apparatuses—that, according to Alberto Corsín Jiménez, allow these rogue builders and engineers to claim the "right to infrastructure."¹³ Their adoption of an archival form that embodies its contents' radical potential, and their embrace of practices that are intentionally contrary to official development priorities, mean that this work, too, necessarily eludes the urban operating system.

Such activity in the city's streets parallels transformations in politics, with protest movements like the Arab Spring, Greece's *Aganaktismeni*, Spain's 15M-Indignados, and Occupy seizing upon urban occupation and, in many cases, open-source ideology in their "critique of representation," their rejection of political parties and the state, and their embrace of direct democracy."¹⁴ Dramatic global political shifts over the past two years have driven many into the streets for women's marches, anti-Brexit protests,

pro-EU protests, anti-corruption marches, Black Lives Matter demonstrations, pro- and anti-refugee protests, and marches in favor of climate action and, in the US, where facts are under siege, even science. Regardless of the form of democracy these movements espouse, they often take the city—its streets and squares and civic labs, its diverse and often disenfranchized communities, and, notably, its communication infrastructures—as their platforms. As we see in those American cities declaring themselves sanctuaries for undocumented immigrants, or committing themselves to the Paris climate accord, in defiance of the federal government, the city is fast supplanting the state as a site of democratic action. This new urban *demos* would reject a proprietary urban operating system in favor of open data, a digital commons, and open-source tools for community organization and democratic engagement. But they must also extend their "critique of representation" to those digital tools themselves—to the limited variety of urban experiences, intelligences, and subjectivities that can be represented in algorithmic form."¹⁵

A more expansively conceived urban operating system would encompass not only digital infrastructures, but also intellectual, cultural, and architectural ones. Layers of material cultural heritage, from aqueducts to *agorae*; entanglements of ecological evolution; even eruptions of geologic forces: these are the "legacy systems" upon which our cities are built, and with which they must smartly negotiate. As Gutiérrez proposes, a more capacious O.S. would embrace open tech and open data as well as a set of "common practices and human relationships"; it would "recognize and protect" existing citizen intelligences and practices—particularly those "that reproduce the commons." All those infrastructural improvisations and ecologically sensitive adaptations; those community archives and resource repositories: these are the means by which many societies manage to preserve a commons amidst much social and political instability, despite much stupidly myopic state and corporate command. The smartest of tomorrow's cities will be those that acknowledge the myriad local intelligences and situated knowledges already existing in their material assemblages and social assemblies.

Yourself Existing': Uncovering the Affective Impact of Community Archives," *The American Archivist* 79 (2016): 56–81; Genocide Archive of Rwanda, http://genocidearchiverwanda.org.rw/index.php/Welcome_to_Genocide_Archive_Rwanda; S. Mattern, "Marginalia: Little Libraries in the Urban Margins," *Places Journal* (May 2012), <https://placesjournal.org/article/marginalia-little-libraries-in-the-urban-margins/>.

¹³ A.C. Jiménez, "The Right to Infrastructure: A Prototype for Open Source Urbanism," *Environment and Planning D: Society and Space* 32, no. 2 (2014): 342–362.

¹⁴ L. Oikonomakis and J.E. Roos, "A Global Movement for Real Democracy? The Resonance of Anti-Austerity Protest from Spain and Greece to Occupy Wall Street," in *Street Politics in the Age of Austerity: From the Indignados to Occupy*, eds. M. Ancelevici, P. Dofour and H. Nez (Amsterdam: Amsterdam University Press, 2016), 227.

¹⁵ See Gutiérrez and "The City that Has Its Own Operating System," *Motherboard* (October 29, 2015), https://motherboard.vice.com/en_us/article/the-city-that-has-its-own-operating-system; K. Finley, "Out in the Open: An Open Source Website that Gives Voters a Platform to Influence Politicians," *Wired* (May 5, 2014), <https://www.wired.com/2014/05/democracy-os/>; P. Mancini, "How to Upgrade Democracy for the Internet Era," *TED Talks* (October 2014), https://www.ted.com/talks/pia_mancini_how_to_upgrade_democracy_for_the_internet_era.

BEYOND ANTHROPOS

176

The current acceleration of technological changes brings more and more into doubt the human's sovereignty on the planet. Various discussions shed light to older fears, but also hopes concerning the Machine's empowerment. *Is it possible, for instance, that future forms of 'artificial superintelligence' might supersede the human? Can additive manufacturing and robotic systems enhance human's abilities?*

Exploring questions such as the above, the works presented focus on the formation of a new hybrid condition between human and machine, one that renders even their distinction difficult. Objects, bots, advanced A.I. agents with affective skills, and wearables, offer the ground to discuss various aspects of this condition: from the future of companionship, and personal relationships, to the organization, and the governance of the future city. They speculate on the changes that tomorrow might bring, if decisions are to be taken more and more by machines. Maybe the relationship of the human to the elements of the nature, the shells, the networks, and the society, would then find a new, peculiar balance. But this would inevitably mean that the development of the future city would also be beyond the human's control...



!Mediengruppe Bitnik, Ashley Madison Angels At Work in Athens, 2017.

AIR SHAKE

LYDIA KALLIPLITI & ANDREAS THEODORIDIS
WITH ERICA VINSON, XUEPING LI, DAKOTA PACE
& SERAPHIM LE
CASE - CENTER FOR ARCHITECTURE, DESIGN & HISTORY, NEW YORK



Lydia Kallipoliti & Andreas Theodoridis with Erica Vinson, Xueping Li, Dakota Pace and Seraphim Le,
Air Shake, 2017.





Adam Harvey, *Stealth Wear*, 2013.

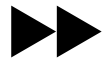

Adam Harvey



Stealth Wear is a vision for fashion that addresses the rise of surveillance, the power of those who surveil, and the growing need to exert more control over privacy. It explores the aesthetics of privacy and the potential for fashion to challenge authoritarian surveillance technologies. The project is a collection of metal-plated garments that evade the thermal cameras used on military drones. The collection is inspired by traditional Islamic dress and the idea that garments can provide a separation between man and God. In *Stealth Wear*, this idea is reimagined in the context of drone warfare as garments that provide a separation between man and Drone. The 'anti-drone' burqa, hijab, and hoodie are fabricated with a highly-flexible silver-plated fabric that reflects the wearer's thermal radiation. This fabric can prevent observation for overhead thermal imaging systems, such as those used by military drones and heat-seeking munitions.

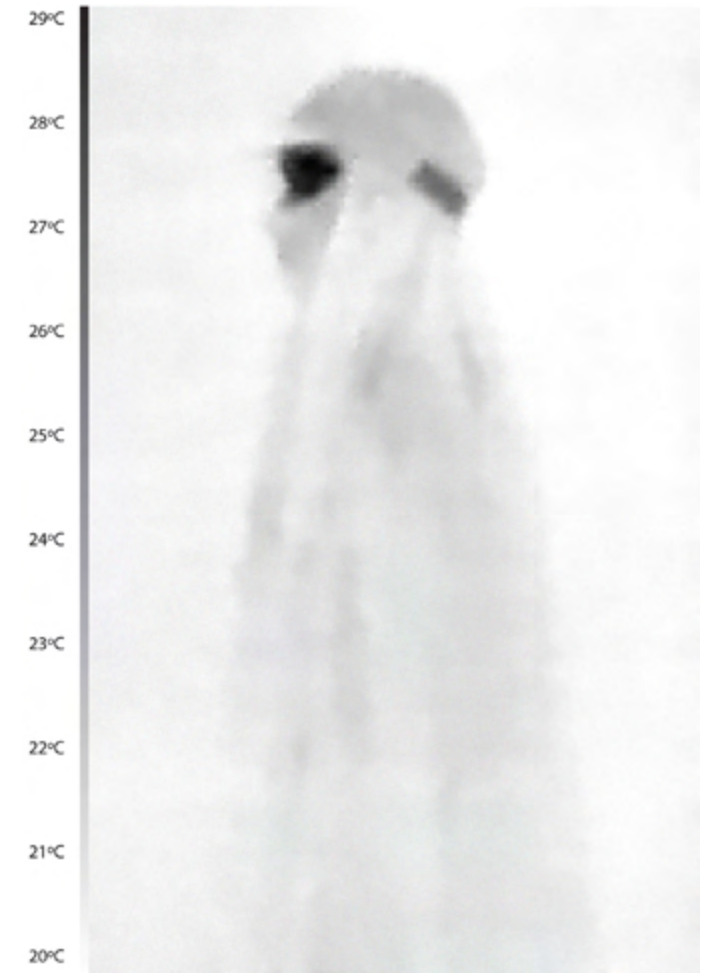

Opposite page:
Anti-Drone Burqa.
Current page
Top: Anti-Drone Burqa.
Bottom: Anti-Drone Hijab.



Anti-Drone Hoodie.



Top: Anti-Drone Burqa.
Bottom: Anti-Drone Hoodie.



Ava Aghakouchak & Maria Paneta

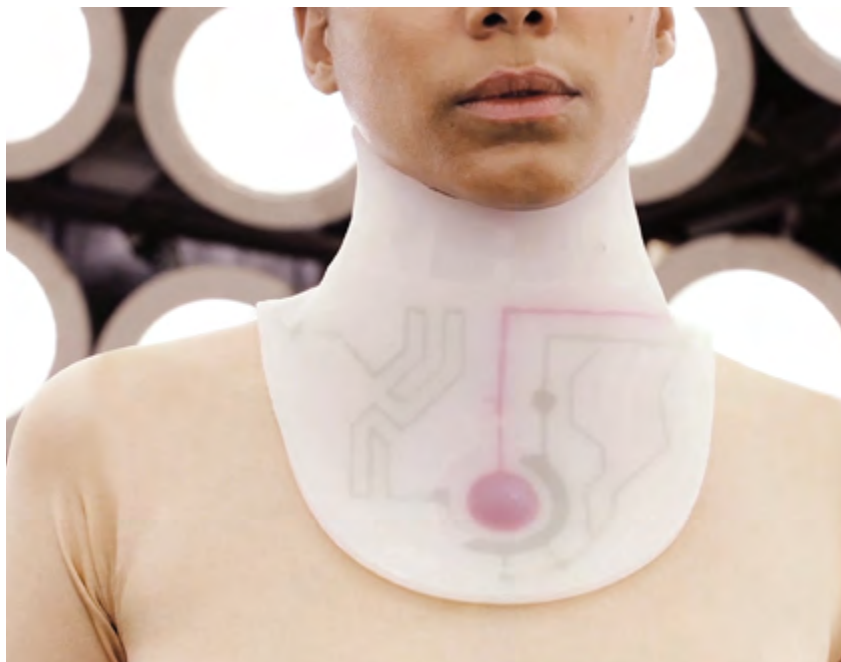

Sarotis, a Greek word for scanner, is a series of soft robotic prosthesis combined for the first time with 3D vision systems to create a whole new way of sensing space through the body. It is predicted that by 2020, 5.4 billion mobile devices will feature 3D sensors enabling any user to scan and store their environments. If 3D vision technologies turn out to be as successful as their 2D predecessors, 70% of the world's population is expected to be capable of scanning, storing and analysing their environments.

Sarotis, developed at the Interactive Architecture Lab, Bartlett UCL, aims to explore how 3D vision technologies will change the way humans see and interact with the world. It looks into possible intimate wearable technology futures and examines how advanced vision systems and other sensory technologies will possibly be connected directly to the body through their 'soft interfaces.' As part of the study an experimental prosthesis and a film were produced. The prosthesis was designed to study how one's awareness of space can be amplified using live 3D scanning technologies that control the inflation and deflation of soft robotic wearables. The speculative film invites the viewer to consider how fluidic hydrogel interfaces may dissolve the distinction between our own physiology and that of the softening machines that will extend our bodies.

Other possible applications of the project include assisting the blind or visually impaired with navigation, or in providing haptic feedback for virtual reality environments.

Project team:
Ava Aghakouchak & Maria Paneta (research & design); Ruairi Glynn, Fiona Zisch, Vincent Hygh (tutors).
Short Film team: Mariana Muñoz Ortega (fashion director); Minjoo Chae (cinematographer); Ophelia Aasa (model); Anita-Beatrix Gerecs (hair & make-up artist); Jon Hopkins (audio); Peter Raynham (Bartlett Artificial Sky).

Project developed and released by Interactive Architecture Lab in the Bartlett led by Ruairi Glynn.

interactivearchitecture.org/lab-projects/sarotis

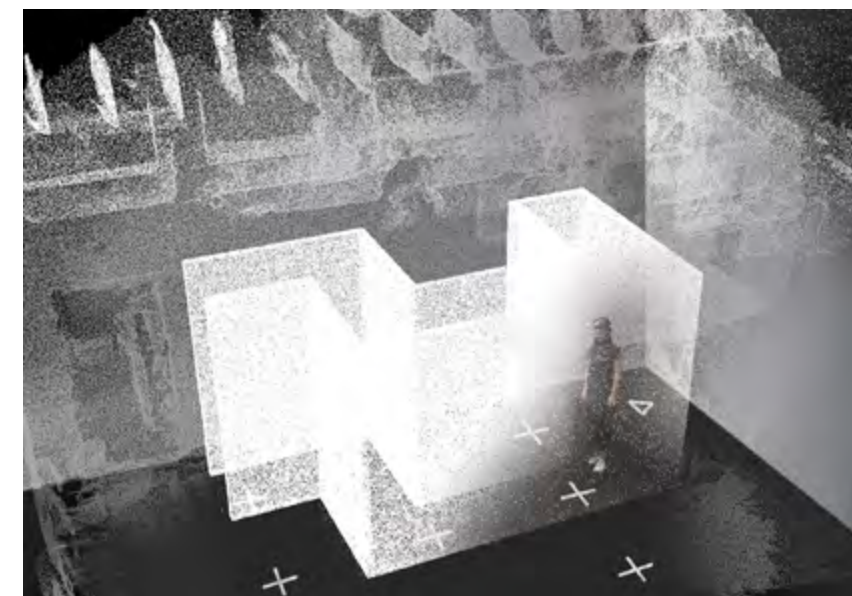

Opposite page:
Sarotis: Wearable futures, film still, 2016.
Current page
Top: Sarotis: Wearable futures, film still, 2016.
Bottom: Experimental maze.

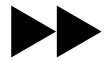

Victoria University
of Wellington



The 1950's television series *The Twilight Zone* focused on the cross over between humanity's fear, intelligence and superstition. In the original series, an episode called "The Lonely" focused on a man sent to prison on asteroid for solitary confinement but falls in love with a woman like robot who becomes his companion. In that time, our fears where catalyzed through magic or science fiction, but our fears now lie in the unprecedented growth of technology. With our smartphones becoming a deposit of our life, our friend, what will this relationship be in 50 years?

Speculative design can help us extrapolate our current beliefs onto tomorrow's technology. During a schooling semester, students were asked to design objects over the next three generations. The overwhelming majority focused on companionship, a friend from birth till death. With our fears and superstitions turned up to a deafening volume we can speculatively assess what future designers of technology companionship should consider. The works present students' different fears and excitements over the future of technological friendship, consulting complex realm of ethics, reality and logic. Some are optimistic, some are not but upon meta-analysis of all the students views it becomes apparent that the future of technological companionship is under negotiation.

Project team:
Ross Stevens, Simon Fraser and Samuel Munneke, with Nichole Hone, Evangeline Martin and Loek Ties Hendriks

3D printed objects were sponsored by Stratasys Ltd. using J750 full-color multi-material printing technology.



Evangeline Martin, *Bot*, 2016.
A reduction *ad absurdum* argument against technological companionship. Each newborn is assigned a technical companion or *Bot*, a cross between a smartphone and a pet that grows up with you. The film shows a young man's interaction with the companion which controls his Facebook feed, shows him movies and music and also communicates with him. As the story unfolds it shows him losing his grip on reality revealing that this companion limits real communication which is what humans crave.



Nicole Hone, *Play, Protect, Preserve*, 2016. The film captures the evolution of a new culture that has emerged to strengthen the relationship between humans and biology—where children are involved in sustainable play—a proposition inspired more from a biological perspective than a technological one. First developed in 2026, *Natolo* is an interactive flying toy that will encourage children to play games outdoors as it harnesses the power of the sun with its solar powered wings and tail fins. By 2086, humanity is preparing to temporarily shift its population to Mars, giving Earth time to heal from its abusive actions. Once born to consume, humans are now born with a living resource provider known as *Sero*. This creature toy symbiotically grows with the child and provides nourishment until it detaches itself from the human. When fully grown, *Sero* develops into a safe, sustainable dwelling or playground, helping to terraform Mars.



Loek Ties Hendriks, *Postcards from Mars*, 2016. *Postcards from Mars* depicts a scenario where growing concerns of an ever-increasing population on Earth precipitates a human migration to Mars. Since this planet is so different everyone is required to have a *Creature* companion with them from childhood, which connects children to virtual knowledge and guides them through life on the planet. The 3D printed model is a duplicate *Creature* sent back to family on Earth along with the postcards from Mars.



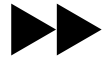

Lydia Kallipoliti,
Andreas Theodoridis
with Erica Vinson,
Xueping Li, Dakota
Pace and Seraphim Le

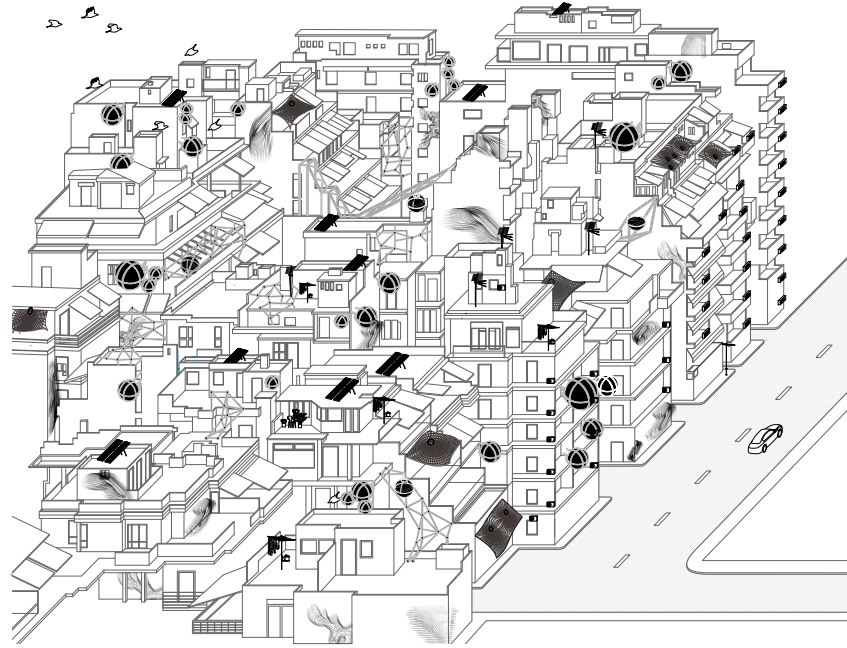

Air Shake examines the character of air pollutants in Athens of the year 2027 to imagine both an array of future diseases and cures. It documents phenomena of leaching caused by a variety of chemicals that have been released into the atmosphere and their scientific, economic, and social attributes. *Air Shake* projects current urban habits in plausible future scenarios extracted from the present, based on the impact that different mixtures of air impose on human bodily systems. The project imagines an array of diseases that have begun to manifest in 2012, with Athens registering the highest levels of atmospheric pollution in decades. Because of the debt crisis and the citizens' denial to yield to the overblown energy taxation, the continuous combustion of random cheap available materials, has resulted in the excessive release of particulate matter, sulfur dioxide, carbon monoxide, and other carcinogens, eventually disemboweling the livelihood of citizens and their right breathe in the city. The projection of four speculative diseases onto the urban environment takes form as a series of healing environments, making visible the linkage between the air pollution and the imagined disease.

The *Air Shake* installation operates around two systems that together create an immersive experience. First, there is a series of chimneys, which present the city upside-down, spewing different shakes of air mixes to heal city dwellers. A secondary system is visualizing the air shakes each chimney spews in a virtual reality environment, accessible through a series of movable tablets installed in the room. The installation space is imagined as a virtual healing environment that allows the physical embodiment of the visitors to project and immerse themselves in a series of future atmospheres.

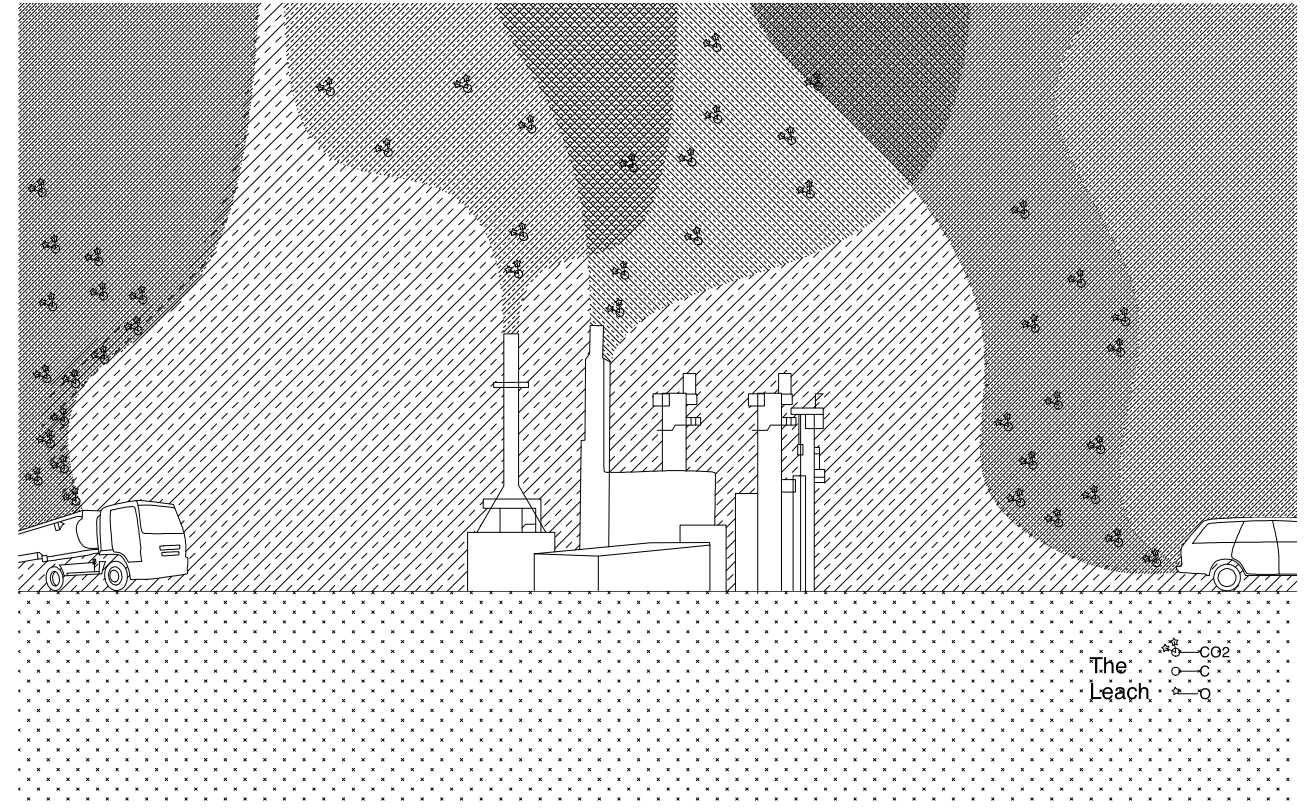

Opposite page:
Athens now accommodates a series of air cure plug-ins introduced to the urban infrastructure. Each plug-in utilizes new mixes of air pollutants to cure prevalent future diseases. Pods, membrane canopies, scaffolds, and spraying pistons are added to the city fabric, creating a secondary system of habitats of altered atmospheres.

Current page
Top: Crude Oil production, and the subsequent burning of these fuels, releases large quantities of carbon dioxide into the atmosphere. It contributes to global warming, but also serves as the waste product of human respiration.
Bottom: BPA, a common binding component in commercial plastics, effects women and their unborn children if ingested. BPA leaches into the water and other products held in BPA bond plastics, but is also released into the atmosphere, thus ingested through the air.

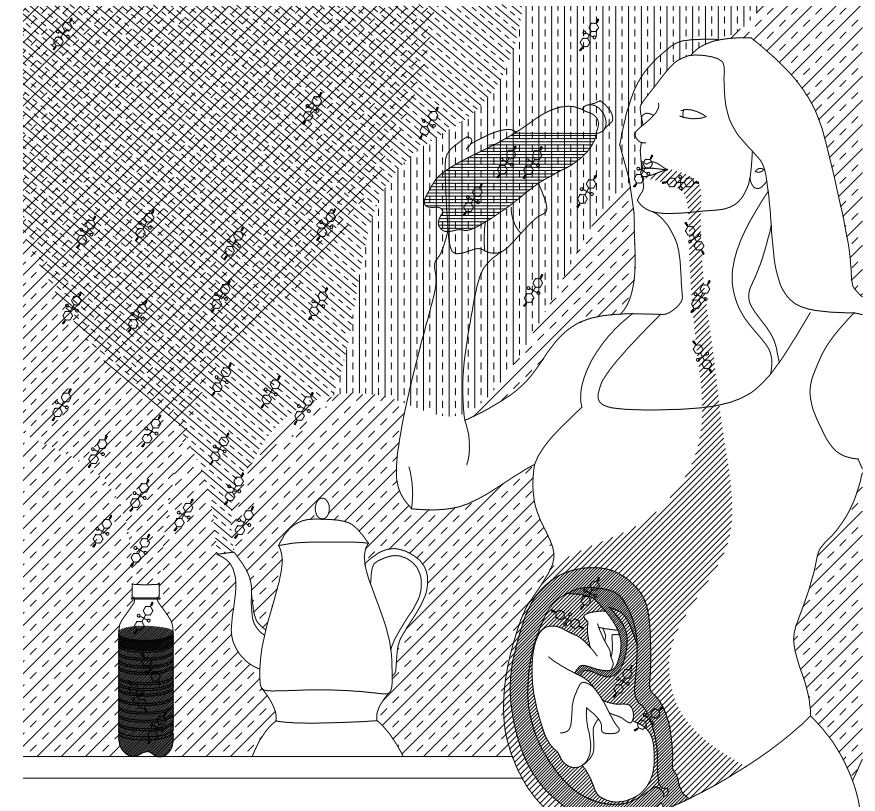

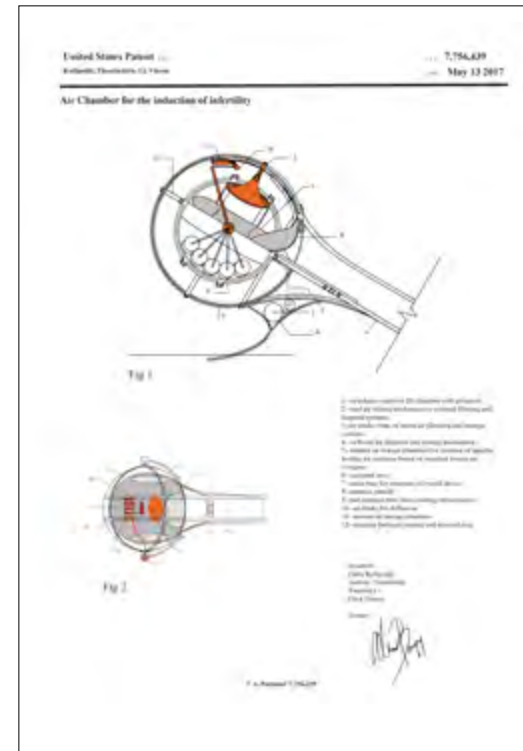
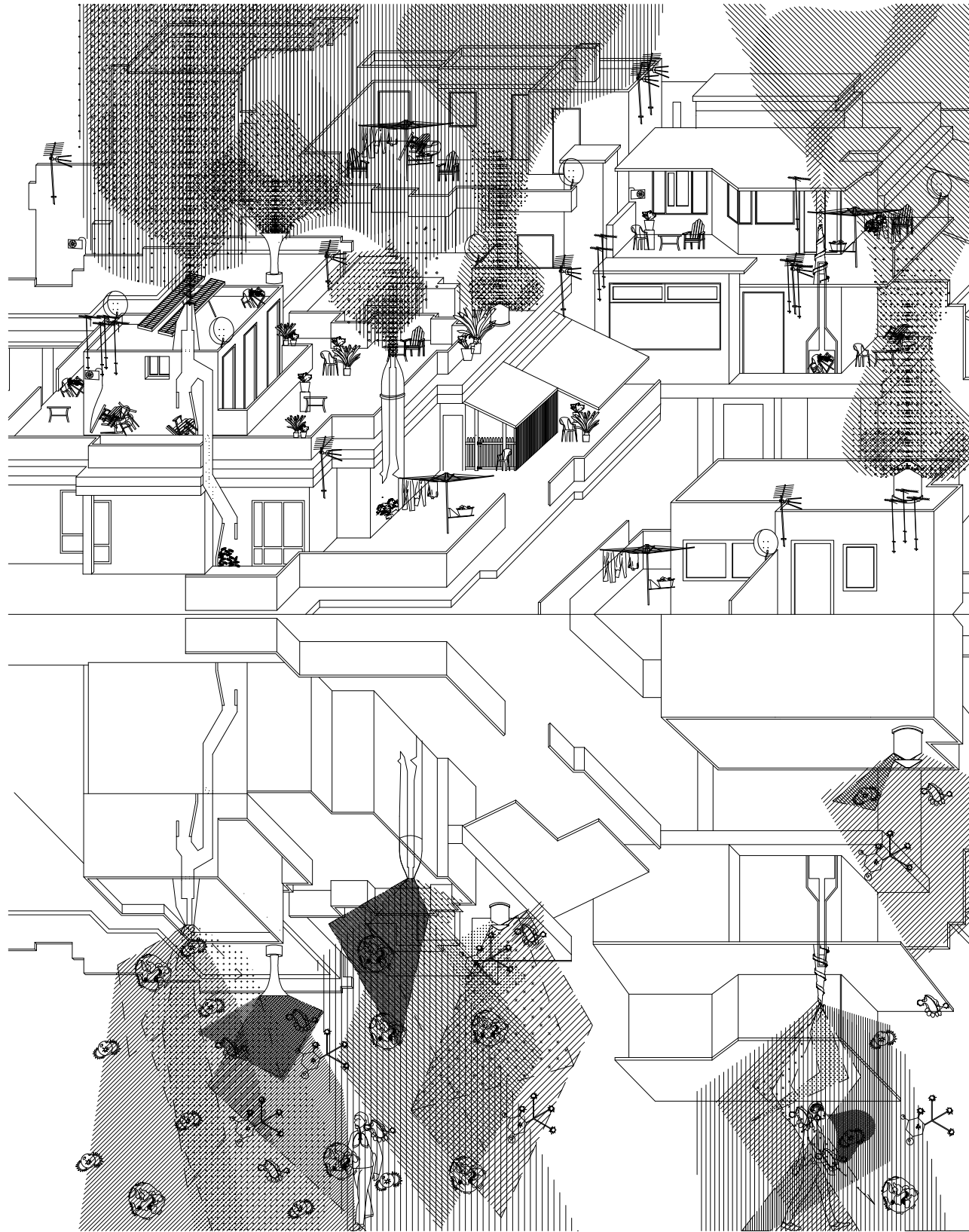

Opposite page:
Athens is a city of smog generated by burning non-traditional fuel and aggregate stuff individually in domestic settings. The city is covered by a layer of vitiated air, with dense large-particulate matter pollutants, carbon dioxide, a variety of volatile organic compounds and other toxic aggregates. If viewed upside down, the city's chimneys can spew shakes of air waves that are mixed differently, as atmospheres and cures, customized for future inhabitants.

Current page
Above: The air chamber for the induction of infertility is a device patented in the future as expedient temporary contraception with no other side-effects to human health. The air chamber collects those chemicals in the urban air that affect the balance of the human reproductive system and remixes them in a new shake.

Right: Due to large increases in urban populations, the control of landfills has been largely outstripped by the necessity to create them. This has created large numbers of either completely uncapped landfills, or landfills that have failing containment procedures. The off gasses of wide variety of organic and inorganic material that is decomposing in such a concentrated environment introduce a wide variety of pollutants into our environments.





Manolis Daskalakis-
Lemos

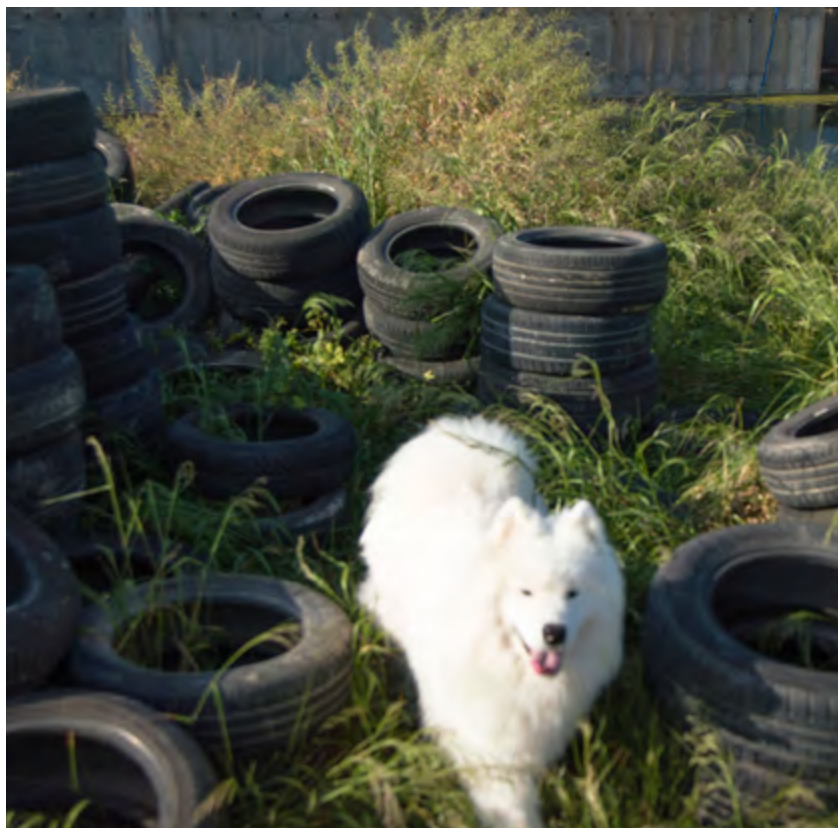

Feral Remnants (Dog) offers a poetic projection onto a further future with no human presence in sight. The work is a multimedia installation consisting of a metal tank filled with black oil and an HD video with an original music score. The video features a purebred Samoyed dog being shot wandering in an empty environment in slow motion. The musical score (*Medieval*, 2016, composed by Ori, the artist's rock trio) creates a certain dystopic heavy atmosphere, yet the screaming voice evokes a sense of riot. No human is to be seen. The dog is reversely projected onto the wall screen, and distortedly reflected on the petroleum which trembles according to the bass sequences of the music. Petroleum evokes the silent hope of discovering oil under the Greek territory, while also stands as a symbol of a pragmatic vision of tomorrow and a blurry dysfunctional dream. The modernist design of the iron tank refers to an idealistic envisaging of the future, while the sculpture mediates the viewing of the abstract and poetic image of the dog. However, the work inevitably describes a future where the lonely dog runs loose in an environment where humans are extinct. Depending on the interpretation of the installation, the viewer is left with an ambivalent sense of melancholia or a certain spark of promise about the future.

Project team:
Manolis Daskalakis-Lemos with
Ori



Video stills.
Courtesy of CAN Christina Androulidaki gallery.



!Mediengruppe Bitnik



Ashley Madison Angels at Work in Athens is part of a series of works researching Ashley Madison, a Canadian online dating service marketed worldwide to married people seeking casual sex. In July and August 2015, an anonymous group called The Impact Team stole and released all of Ashley Madison's internal data – including the entire website code and functionality, customer data and the CEO's emails. The data breach revealed that with a disproportionate number of male subscribers and virtually no human women on the site Ashley Madison had created an army of 75,000 female chatbots to draw the 32 million male users into (costly) conversations. This triggered !Mediengruppe Bitnik to use Ashley Madison as a case study to raise questions around the current relationship between human and machine, Internet intimacy and the use of virtual platforms to disrupt the physical.

For *Tomorrows*, !Mediengruppe Bitnik used the localized data from the Ashley Madison hack to give a temporary physical embodiment to 7 of the 165 fembots that were active in Athens at the time of the data breach. Each fembot has a name, an age and a location and uses sentences from a list of pick-up lines to contact other users. The 165 fembots of Athens provided 'entertainment' to around 22.910 registered users in Athens.

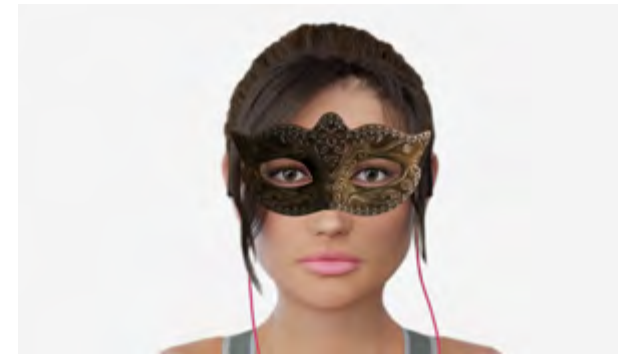

Opposite page:
Installation view. Photo by Mariana Bisti.

Current page:
Stills from *Ashley Madison Angels At Work in Athens*, 2017.

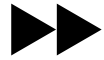

Pinar Yoldas



What if political governance were replaced by one speaking kitten AI? The year is 2039. After years of political turmoil catalyzed by R-Crisis EMEA, a refugee crisis triggered by war and the detrimental effects of climate change, the incompetence of the political elites to generate and retain trust in the populations becomes ever more obvious. Politicians across Europe and EMEA countries fail to serve the sentient human.

One pioneering neuro-engineer develops an artificially intelligent and – for the first time – feeling virtual being. *Kitty AI* is an artificial intelligence with the affective capacities of a cat who can love up to 3 million people. The AI not only carries the tasks of a governor; it also takes care of its citizens at a personal level. It takes care of garbage disposal, makes sure your children get to school safely and drink clean water. She/he/it manages the cities household budget, and maintains diplomatic relations with both physical and virtual leaders of the world.

This speculative future scenario is inspired by the *Black Mirror* episode “The Waldo Moment,” where a cartoon character becomes a presidential candidate, an idea that seems less absurd considering the political developments of 2016/2017. German author Leif Randt’s novel *Planet Magnon* enfold a narrative in which computers run an entire galaxy, a concept that is supported by the emerging field of Global Systems Science.



Video stills.



Eight keywords for tomorrow

— Thomas Doxiadis

208

Humanity is rapidly shifting into a post-natural realm of its own making. It is an anthropogenic realm, in which the old divinities of nature and the godheads will not really do. Apparently, our brains are still hard-wired like our scavenger ancestors, our societies coded during the agricultural revolution from about seven millennia ago. Yet in this new era we are the drivers. Eight keywords might focus our vision to the future.

1:

Exploding and Imploding City

The Mediterranean city has seen a period of explosive growth in the last 50 years, with population growing from 100% to 600% between 1950 and 2000. The next 50 years are a different story. The south is still growing, but in the developed north and west population is currently stagnant, or even in decline. Places such as Athens, Rome, Marseilles and Barcelona are no longer exploding cities. Household expansion is also in reversal due to the declining economies. The result is the pause of growth, even eventual implosion.

The issues of the exploding city have been well studied. What though of the imploding city? When not only the population, but also the economy declines? The past is a guide, with periods of growth and decay, even collapse, such as happened with the death of the antique city after plagues, earthquakes, and major invasions. The story is one of squalor, but also of make-do, of thrift, of creative reuse of existing infrastructure, buildings, materials.

2:

Recycling

Currently something we do with waste, recycling will become the main trope in our existence.¹ Digital resources are limitless, physical resources are finite. We will start reusing more and more. Networks are already established to recycle our plastic, our paper, our metal, our glass. There is partial and fake recycling of our electronics and cars. Our organic refuse is starting to be locally recycled. Soon, we will be recycling our water, our feces, our buildings, our clothes, indeed nothing may be thought of as waste. Implosion and thrift will further drive the trend. The old landfills will become the mines of the future. Soylent green even suggests we might be recycling ourselves.

¹ Oliver Balch, "The future of waste: five things to look for by 2025," *The Guardian*, February 23, 2015, accessed May 14, 2017, <https://www.theguardian.com/sustainable-business/2015/feb/23/future-of-waste-five-things-look-2025>.

3.

YIMBY

If NIMBY thinking is responsible for much of the destruction we have caused upon nature, then YIMBY may become the way of the future. Not a challenge to globalization per se, but a way to spread the impact and the risk, more and more will be done in our own back yards. Renewable energy is already moving production closer to the points of consumption, eventually inhabiting our homes, even our bodies. The trend in waste is similar. No complete decentralization of utilities, but rather a network thinking that will take advantage of economies of scale. Biodiversity is exhibiting similar trends. No longer just about preserving nature in large national parks,² current thinking recognizes the interconnectedness of all systems and the need to manage them as such. Future thinking will move to recolonization of cities and other sterilized human artifacts so that they are part of a vibrant whole. Prepare to live with many new friends.

² Edward O. Wilson, *Half-Earth: Our Planet's Fight for Life* (New York: Liveright, 2016).

4.

Reality

As we become more enmeshed and dependent on the exploding virtual data realm, the importance of the physical realm will become more apparent. The virtual is vastly expanding our horizons, opening experience in evermore ways to realities and fictions external to us. In the dawning reality-virtuality continuum,³ it might seem old-fashioned to center on the actual and the physical. What could be wrong with the virtual? Well, for one thing, our bodies might find it difficult to deal with our brains being somewhere else. Disorders such as Virtual Reality Sickness are gaining recognition. On a darker note, the virtual realm is usually scripted, by agents who might be benign for now but will increasingly be so as they are able to define our total reality. As a pendulum swings strongly in one direction, the opposing force emerges. Fiction has long been a sapiens characteristic,⁴ but the denial of reality is an extreme we should not reach. In the future reality will be a stable base from which to explore the reality-virtuality continuum, or a haven for people or groups who reject the virtual altogether.

³ See https://commons.wikimedia.org/wiki/File:Mixed_Reality_Scale.png.

⁴ Yuval Noah Harari, *Sapiens: A Brief History of Humankind* (New York: Harper, 2015).

5.

Cybnat

Nature used to be our ruler, an instrument of the divine or divinity itself. Now the tables are turning.⁵ Anthropogenic changes to the environment occur at all scales from local to global, and indeed so much of nature is now broken that we are investing more and more resources to fixing through active management. While changes in the past were inadvertent, in the future they will need to be well thought-out. Natural systems will no longer operate on their own, nor will they be totally human-controlled. Earth will be a managed cybernetic system where natural processes, human volition, and large scale machinic, biological and AI interfaces

⁵ Bill McKibben, *The End of Nature* (New York: Anchor, 1989).

209

are bound to form a new, continuous whole. Who will direct this management however, and what of those who do not want to be part of this global benevolent system?

6.

Global citizenship

The trend in the last century has been from citizen to consumer. Yet there is a counterbalancing force, focusing on responsibility, morality, and the power that comes with conscious citizenship. At first, citizens were only land-owning males. Then all free males. Then all males. Then all humans. Now humanity is realizing that apes, whales, dolphins, dogs and other higher animals have intrinsic rights.”⁶ Eventually humanity will realize that all living things have intrinsic rights, all are subjects, all are citizens. Advocates for these other citizens already exist among the humans, especially for the higher animals, and the cycle is expanding. Will we find ways to give animals a direct voice? What will happen when they change not only our politics, but our very understanding of the world?

7.

Post-posthuman

The virtual realm, the machinic, cybnat, and eventually AI will change our species. In the Utopian scenario, eventually we will all be work-free”⁷ (unemployed) observers of a world run (by us, or for us, or not) by the global AI-bio-mechanic system(s). Our reality will be part-virtual, part-physical. We ourselves will be cyborgs, sharing the world with cyborg whales, dogs and other expanded citizens, part of the cybnat whole. If this is the posthuman, should we not already be thinking of the post-posthuman?”⁸

8.

Symbiosis

As a species expanding to take over the face of the earth, collaboration and competition have been the two paradigms for our success. Our role up to now has been parasitic, slowly killing off our host (the Anthropocene has already seen the die-out of close to 50% of global species).”⁹ Our overwhelming success might be reaching the limits of our host organism, the Earth, and this imbalance might lead to our own implosion, in which case we will be an unsuccessful parasite. As trustees and part of cybnat, we will have to develop a new mentality, that of mutualistic symbiosis, of balance, of measure. What effects will this new mentality have on all of our conceptual frameworks?

⁶ Sue Donaldson and Will Kymlicka, *Zoopolis: A Political Theory of Animal Rights* (Oxford: Oxford University Press, 2011).

210 ⁷ Nick Srnicek and Alex Williams, *Inventing the Future: Postcapitalism and a World Without Work* (New York: Verso Books, 2015).

⁸ Heidi Campbell, “Postcyborg Ethics: A New Way to Speak of Technology,” *Explorations in Media Ecology* 5, no. 4 (2006): 279–296.

⁹ WWF and the Zoological Society of London, “Living Planet Index 2016,” <http://www.livingplanetindex.org/home/index>.

EXHIBITION

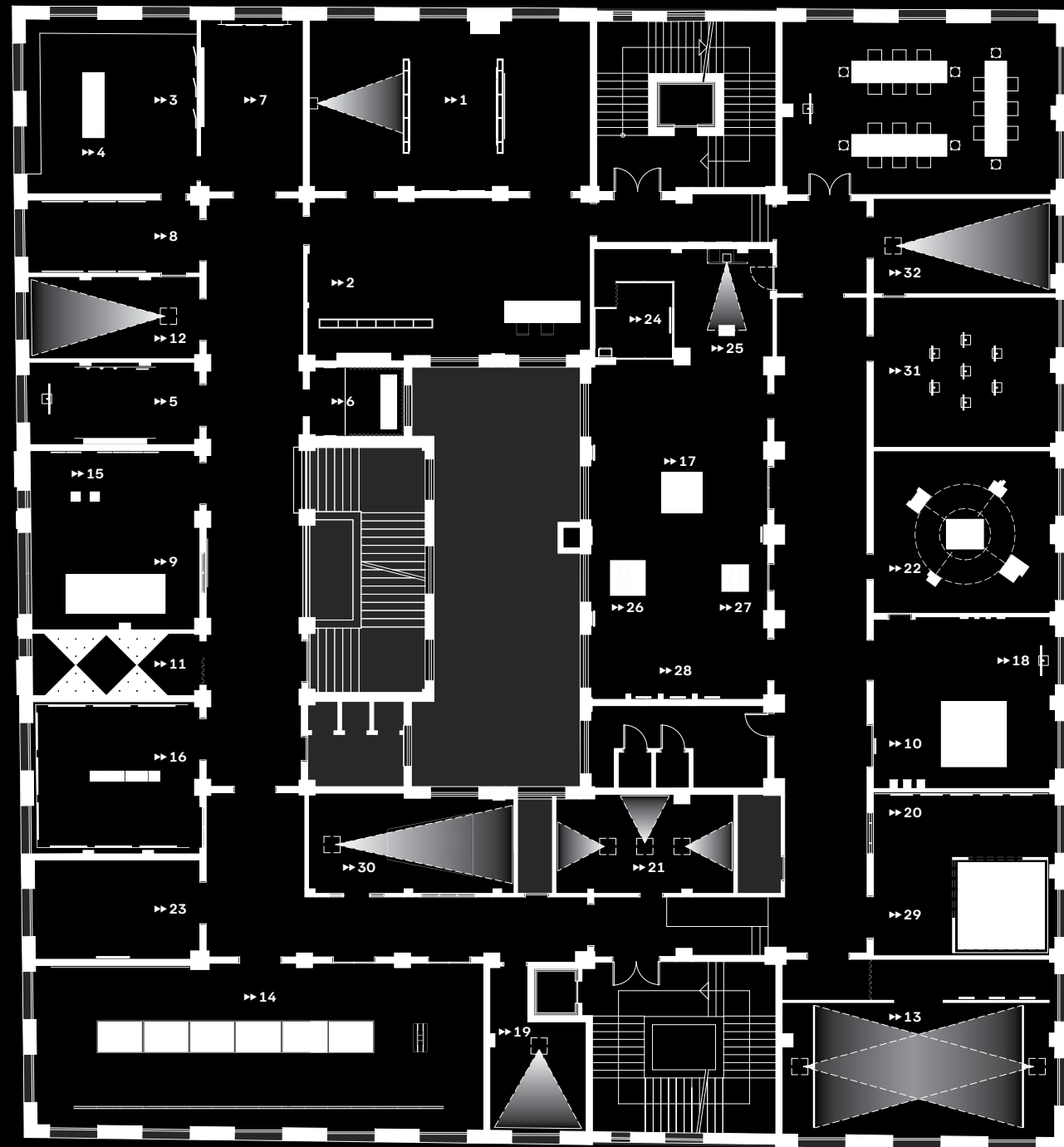

- ▶ 1 Constantinos A. Doxiadis, *Ecumenopolis*
- ▶ 2 Shu Lea Cheang, *Mediterranean Touch Screen*
- ▶ 3 Demetra Katsota & The Coastal Domains Option Studio, Department of Architecture, University of Patras, *Coastal Domains*
- ▶ 4 Stefania Strouza & The New Raw, *Making Shores / Making Nature*
- ▶ 5 Morehshin Allahyari & Daniel Rourke with ARTEKLAB, Geraldine Juárez, Darlene Farris-LaBar and Antonio Esparza, *The 3D Additivist Cookbook: On Mediterranean post-natures and the cultural now*
- ▶ 6 Erich Berger & Mari Keto, *Inheritance*
- ▶ 7 Design Earth, *Geographic Leviathan*
- ▶ 8 Cathryn Dwyre & Chris Perry, *Transitional Environments*
- ▶ 9 Aristide Antonas, *Cave for an Unknown Traveler*
- ▶ 10 Zissis Kotionis, *Hot_Camp: A Trans Urban block*
- ▶ 11 Zenovia Toloudi / Studio Z, *Silo(e)scapes*
- ▶ 12 Emma Charles, *White Mountain*
- ▶ 13 Liam Young, *Tomorrow's Storeys*
- ▶ 14 Takis Ch. Zenetos, *Electronic Urbanism*
- ▶ 15 Kyriaki Goni, *The Aegean Datahaven: A collaborative platform in the archipelago*
- ▶ 16 Michael Young & the Yale School of Architecture Advanced Studio, *The Icelandic Infrastructure 2036–2056*
- ▶ 17 New Affiliates & Farzin Farzin, *Time Fears the Pyramids*
- ▶ 18 Tobias Revell, *New Mumbai*
- ▶ 19 Lina Theodorou, *a2525, Athens in S.F.*
- ▶ 20 Point Supreme, *Tomorrow's Commons*
- ▶ 21 Penelope Haralambidou & MArch Unit 24, Bartlett School of Architecture, UCL, *Cinematic Essays of Urban Futures*
- ▶ 22 AREA – Architecture Research Athens, *Victoria: Way In / Way Out: The Shelter, the Embassy and the Transparent State*
- ▶ 23 Metahaven, *City Rising*
- ▶ 24 Vassiliea Stylianidou, *Hello! My name is B_o_o_____d_y_ and I am here to abduct the f_u_t_u_r_e*
- ▶ 25 James Bridle, *Homo Sacer*
- ▶ 26 Adam Harvey, *Stealth Wear*
- ▶ 27 Ava Aghakouchak & Maria Paneta, *Sarotis: Wearable Futures*
- ▶ 28 Victoria University of Wellington, *Birthright*
- ▶ 29 Lydia Kallipoliti & Andreas Theodoridis, with Erica Vinson, Xueping Li, Dakota Pace and Seraphim Le, *Air Shake*
- ▶ 30 Manolis Daskalakis-Lemos, *Feral Remnants (Dog)*
- ▶ 31 !Mediengruppe Bitnik, *Ashley Madison Angels At Work in Athens*
- ▶ 32 Pinar Yoldas, *The Kitty AI: Artificial Intelligence for Governance*

LIST OF EXHIBITED WORKS

Constantinos A. Doxiadis, *Ecumenopolis, 1959–1974*

Archive material: Digital reproductions of drawings, diagrams and photos; two original maps 100x100cm; video, sound, 12'31".

Courtesy of Constantinos A. Doxiadis Archives.

© Constantinos and Emma Doxiadis Foundation

Shu Lea Cheang, *Mediterranean Touch Screen, 2017*

Installation: Polycarbonate wall, keyboard membranes, keys, sound data, computer, speakers. The project was commissioned by the Onassis Cultural Centre on the occasion of the exhibition *Tomorrows*, 2017.

Demetra Katsota & The Coastal Domains Option Studio, Department of Architecture, University of Patras, *Coastal Domains, 2017*

Installation: 16 atlases, 32x32cm mounted on the wall with metal fixtures; wooden ladder 113x177cm, courtesy of Mrs. Marilena Cassimatis.

Stefania Strouza & The New Raw, *Making Shores / Making Nature, 2017*

Installation: 3D printed objects from recycled plastic, aluminum, glass, laser cut on plastic (overall dimensions: 54x150cm); book 29x36cm. The project was commissioned by the Onassis Cultural Centre on the occasion of the exhibition *Tomorrows*, 2017.

Morehshin Allahyari & Daniel Rourke with ARTEKLAB, Geraldine Juárez, Darlene Farris–LaBar and Antonio Esparza, *The 3D Additivist Cookbook: On Mediterranean post–natures and the cultural now, 2015–2017*

HD video, color, sound, 10'11"; 3D pdf; 3D printed objects in plastic, 3D printed object in nickel.

Erich Berger & Mari Keto, *Inheritance, 2016*

Jewelry with radioactive stones, copper plates, cement layers, mounting rods, screws, leather rings; photo, color 45x45cm printed on photo paper and mounted on dibond; radiography 42x59cm.

Design Earth, *Geographic Leviathan, 2016*

Nine 60x60cm drawings printed on canvas with wooden frame; lightbox with backlit printed drawing 292x60cm.

Cathryn Dwyre & Chris Perry, *Transitional Environments, 2015–2017*

Two drawings 150x150cm printed on photo paper and mounted on PVC; four drawings 100x150cm printed on photo paper and mounted on PVC.

Aristide Antonas, *Cave for an Unknown Traveler, 2014–ongoing*

Installation: Model and book 365x145x147cm, tyvek, aluminum, polystyrene foam painted with polyurethane paint. The project was commissioned by the Onassis Cultural Centre on the occasion of the exhibition *Tomorrows*, 2017.

Zissis Kotionis, *Hot_Camp: A Trans Urban block, 2017*

Installation: 240x240x70cm model consisting of metal sheets, ceramic and plastic pots, glass panels, bricks, cement bricks, reed and plants; three drawings 30x140cm, hard hats; HD video, color, sound, 4'10". The project was commissioned by the Onassis Cultural Centre on the occasion of the exhibition *Tomorrows*, 2017.

Zenovia Toloudi / Studio Z, *Silo(e)scapes, 2017*

Installation: Model 225x450x210cm, wood, mirrors, plexiglass, Mediterranean seeds, led lights, electronic circuit, microcontroller, sound system, lego-like figures.

Emma Charles, *White Mountain, 2016*

16mm video transferred to HD, color, 5.1 surround sound, 20'20".

Liam Young, *Tomorrow's Storeys, 2017*

Two channel animated installation: HD video, color, sound, 15'17". The project was commissioned by the Onassis Cultural Centre on the occasion of the exhibition *Tomorrows*, 2017.

Takis Ch. Zenetos, *Electronic Urbanism, 1952–1971*

Archive material: 27 digitally reproduced original drawings in various dimensions, printed in photo paper and mounted on kappa board; 16 digitally reproduced drawings and photos in various dimensions, printed in photo paper and mounted on PVC; 49 original drawings in various dimensions; 15 original documents in various dimensions; three original models 102x52x53cm on an acrylic base, 45x30x40cm, 23.5x23.5x34.5cm.

Courtesy of Takis Ch. Zenetos family.

Kyriaki Goni, *The Aegean Datahaven: A collaborative platform in the archipelago, 2017*

Framed drawings: Three 100x70cm, graphite on paper, one 100x70cm graphite and ink on paper; four 100x33cm graphite on paper; website. The project was commissioned by the Onassis Cultural Centre on the occasion of the exhibition *Tomorrows*, 2017.

Michael Young & the Yale School of Architecture Advanced Studio, *The Icelandic Infrastructure 2036–2056, 2016*

81 drawings 45x45cm printed in nine groups of 135x135cm on photo paper and mounted on PVC; six models 45x45cm of 3D printed and mixed materials.

New Affiliates & Farzin Farzin, *Time Fears the Pyramids, 2017*

Installation: Wireless printer, thermal printer, portable Bluetooth speaker, monitor, iPad mini, led sign, image printed on adhesive sticker. The project was commissioned by the Onassis Cultural Centre on the occasion of the exhibition *Tomorrows*, 2017.

Tobias Revell, *New Mumbai, 2012*

Five images printed on photo paper and mounted on dibond, three 37.5x25cm, two 25x18.5; HD video, color, sound, 9'17".

Lina Theodorou, *a2525, Athens in S.F., 2017*

HD video, color, sound, 24'27". The project was commissioned by the Onassis Cultural Centre on the occasion of the exhibition *Tomorrows*, 2017.

Point Supreme, *Tomorrow's Commons, 2008–2017*

Five digital images 80x60cm printed on photo paper and mounted on PVC.

Penelope Haralambidou & MArch Unit 24, Bartlett School of Architecture, UCL, *Cinematic Essays of Urban Futures, 2015–2016*

Nine HD videos, color, sound.

AREA – Architecture Research Athens, *Victoria: Way In / Way Out: The Shelter, the Embassy and the Transparent State, 2017*

Installation: Plexiglass model with mixed media, 120x70x100cm; four suspended polystyrene and paper models with mixed media in various dimensions; two wall-mounted plastic figurines. The project was commissioned by the Onassis Cultural Centre on the occasion of the exhibition *Tomorrows*, 2017.

Metahaven, *City Rising, 2014*

HD video, color, sound, 10'40".

Vassiliea Stylianidou, *Hello! My name is B_o_____d_y__ and I am here to abduct the f____ut__u_____re____, 2017*

Multichannel sound installation: Text animation video; 5.1 surround sound; HD video, color, 46'19". The project was commissioned by the Onassis Cultural Centre on the occasion of the exhibition *Tomorrows*, 2017.

James Bridle, *Homo Sacer, 2014*

Installation: Wooden base, perspex, 175x50x50cm; digital video 7'05" looped, rear projection.

Adam Harvey, *Stealth Wear, 2013*

Garment made of silver nylon and black silk; three drawings 21x29.7cm printed on photo paper and mounted on dibond; video shot with a thermal camera, 4'31".

Ava Aghakouchak & Maria Paneta, *Sarotis: Wearable Futures, 2016*

Wearable made of silicone 34x26cm; wearable made of silicone 36x22 cm; HD video, color, sound, 0'51"; HD video, color, sound, 2'46".

Victoria University of Wellington, *Birthright, 2016*

HD video, color, 1'51" sound; HD video, color, 3'05"; HD video, color, 3'50", sound; three 3D printed objects.

Lydia Kallipoliti & Andreas Theodoridis, with Erica Vinson, Xueping Li, Dakota Pace and Seraphim Le, *Air Shake, 2017*

Installation: Construction of wooden panels and 3D sculptures, drawings printed on adhesive paper, 4 iPads. The project was commissioned by the Onassis Cultural Centre on the occasion of the exhibition *Tomorrows*, 2017.

Manolis Daskalakis–Lemos, *Feral Remnants (Dog), 2017*

Installation: Oil and water in iron tank, HD video with sound, 4'13" loop. Courtesy of the artist, Ori and CAN Christina Androulidaki gallery. The project was commissioned by the Onassis Cultural Centre on the occasion of the exhibition *Tomorrows*, 2017.

!Mediengruppe Bitnik, *Ashley Madison Angels At Work in Athens, 2017*

Seven channel video installation: full HD video, color, sound, approximately 10'.

Pinar Yoldas, *The Kitty AI: Artificial Intelligence for Governance, 2016*

HD video, color, sound, 12'17".

Daphne Dragona is a curator and writer living and working in Berlin. She is the conference curator of transmediale festival since 2015. She has collaborated with various institutions for exhibitions, conferences, workshops and other events. Among her curated or co-curated projects are: *Tomorrows* (Onassis Cultural Centre, Athens, 2017), “...” *An archaeology of silence in the digital age* (Aksioma, 2017), *New Babylon Revisited* (Goethe Institut Athen, 2014), *Home/s* (Goethe Institut Athen & Benaki Museum, 2013), *Afresh: A new generation of Greek artists* (National Museum of Contemporary Art, Athens, 2013), *Mapping the Commons - Athens* (National Museum of Contemporary Art, Athens, 2010), *Homo Ludens Ludens* (Laboral, 2008). While exploring diverse fields, her interest always lies in emerging or recurring artistic practices and methodologies that challenge contemporary forms of power. Her articles have been published in various books, journals, magazines and exhibition catalogues. She holds a PhD from the Faculty of Communication & Media Studies of the University of Athens.

Panos Dragonas is an architect and curator, Professor of Architecture and Urban Design at the University of Patras, Greece. In 2001, he established dragonas christopoulou architects in collaboration with Varvara Christopoulou. From 2001 to 2013, he was consultant editor of the annual reviews *Architecture in Greece* and *Design + Art in Greece*. In 2012 he was joint commissioner and curator of *Made in Athens*, the Greek participation at the 13th International Architecture Exhibition, Venice Biennale. He has curated – alone or in collaboration – the exhibitions *Tomorrows* (Onassis Cultural Centre, Athens, 2017), *Adhocracy* [Athens] (Onassis Cultural Centre, Athens, 2015), *Rethink Athens* (Onassis Cultural Centre, Athens, 2013), *14F/21GR: Young Architects from France and Greece* (Hellenic Institute of Architecture, Institut Français d’Athènes & Benaki Museum, 2012) and the 2nd Biennale of Young Greek Architects (Hellenic Institute of Architecture, Athens, 1998). In 2016 he was a Stanley J. Seeger Visiting Research Fellow at Princeton University. His current research and design activities focus on the transformations of the Greek cities during the economic crisis, the investigation of new housing typologies, and the connections between cinema, architecture and the modern city. deltarchi.com

!Mediengruppe Bitnik (read *the not mediengruppe bitnik*) live and work in Zurich and Berlin. They are contemporary artists working on and with the Internet. Their practice expands from the digital to

affect physical spaces, often intentionally applying loss of control to challenge established structures and mechanisms. In early 2013 !Mediengruppe Bitnik sent a parcel to WikiLeaks founder Julian Assange at the Ecuadorian embassy. The parcel contained a camera which broadcast its journey through the postal system live on the Internet. They describe «Delivery for Mr. Assange» as a SYSTEM_TEST and a Live Mail Art Piece. They have also been known for sending a bot called «Random Darknet Shopper» on a three-month shopping spree in the Darknets where it randomly bought objects like Ecstasy and had them sent directly to the gallery space. !Mediengruppe Bitnik are the artists **Carmen Weisskopf** and **Domagoj Smoljo**. Their accomplices are the London filmmaker and researcher Adnan Hadzi and the reporter Daniel Ryser.

www.bitnik.org

Morehshin Allahyari is a new media artist, activist, educator, and occasional curator. She was born and raised in Iran and moved to the United States in 2007. She thinks about technology as a philosophical toolset to reflect on objects; a poetic means to document the personal and collective lives we live and our struggles as humans in the 21st century. Morehshin has been part of numerous exhibitions around the world including Venice Biennale, Museum of Contemporary Art in Montreal, Queens Museum, Pori Museum and Museum für Angewandte Kunst. She was an artist in residence at Vilém Flusser Residency Program for Artistic Research (2016) in association with transmediale, Berlin – in collaboration with the writer/artist Daniel Rourke. Morehshin was an artist in residence at Eyebeam’s one-year Research Residency (2016–17).

morehshin.com

Daniel Rourke is a writer and artist. In his work, he deals with speculative and science fiction in search of a radical ‘outside’ to the human(ities), including extensive research on the intersection between digital materiality, the arts, and post-humanism. In his artistic practice, Daniel devises and creates collaborative platforms that promote open and critical discourse on the topics of media theory and post-humanism. In 2015 he released the *3D Additivist Manifesto* together with artist and activist Morehshin Allahyari. He recently completed his PhD in Art at Goldsmiths, University of London.

machinemachine.net

ARTEKLAB, **Geraldine Juárez**, **Darlene Farris-LaBar** and **Antonio Esparza** are artists and designers who contributed in the *3D Additivist Cookbook*.

Aristide Antonas’ work spans philosophy, art, literature and architecture. As a writer and playwright, he has published novels, short stories, theater scripts and essays. His art and architecture work has been featured at Istanbul Design Biennial, Venice Biennale, São Paulo Bienal, Display Prague, the New Museum, among others; he also had solo institutional presentations at Basel’s Swiss Architecture Museum and Austria’s Vorarlberger Architektur Institut. He won the ArchMarathon 2015 prize for his *Open Air Office*, and was nominated for an Iakov Chernikov Prize (2011) and a European Union Prize for Contemporary Architecture – Mies van den Rohe Award (2009) for his *Amphitheater House*. He works as a Professor of Architectural Design and Theory and directs the Master’s Program on Architectural Design at the University of Thessaly, Greece. Aristide has been a Visiting Professor at the Bartlett UCL and the Freie Universität in Berlin.

aristideantonas.com

AREA – Architecture Research Athens is a professional architectural design practice established in 2006 by architects **Styliani Daouti**, **Giorgos Mitroulias** and **Michaeljohn Raftopoulos**, combining academic and professional experience in Greece, France, the Netherlands and the United States. AREA’s work has received numerous distinctions in competitions for public and private projects, in Greece and internationally, and was distinguished among the best Greek buildings and projects of 2013 and 2015 (DOMES International Review). AREA has received the First Prize at the architectural competition for 220 housing units in Thessaloniki (2007), the First Prize (*ex aequo*) at the national urban design competition AthinaX4 (2011), and Honorable Mention at the European competitions Europan 12 (Nuremberg, 2013) and Europan 13 (Azenha do Mar, Portugal, 2015). Notable exhibitions include AREA’s installation at the Greek Pavilion, *Made in Athens*, at the Venice Biennale 2012, and the *Adhocracy Athens* exhibition at the Onassis Cultural Centre in 2015. In 2017 AREA was nominated for the European Union Prize for Contemporary Architecture – Mies van den Rohe Award, for *Hansen, Mixed Use Building* in Athens. AREA’s members teach architectural design at the Schools of Architecture of the University of Thessaly and the University of Patras.

areaoffice.gr

Erich Berger is an artist, curator and cultural worker based in Helsinki. His interests lie in information processes and feedback structures, which he investigates through installations, situations, performances and interfaces. Throughout his artistic practice, he has explored the materiality of information, and information and technology as artistic material. His current interest in issues of deep

time and hybrid ecology led him to work with geological processes, radiogenic phenomena and their socio-political implications in the here and now. Berger also directs the Bioartsociety, an organization based in Helsinki fostering interactions between art and natural sciences with a focus on biology, ecology and life sciences.

randomseed.org

Mari Keto explores the limits of artifacts by combining jewelry materials in her installations and portraits. In Keto’s works both the conceptual underpinning and a high degree of craftsmanship merge into an artwork. Keto’s work is strongly research-based. She engages with her subject matter from various perspectives in order to define her own. Keto explores the tensions and structures of our contemporary culture by portraying icons and symbols predominantly surrounding us. Deriving from cultural histories and pop culture her work examines the distinctions between value and consumption. Keto’s multi-layered works contain intemperate realism mixed with humor and irony.

mariketo.com

James Bridle is a British artist and writer based in Athens, Greece. His artworks have been commissioned by galleries and institutions, and exhibited worldwide and on the Internet. His writing on literature, culture and networks has appeared in magazines and newspapers including *Wired*, *Domus*, *Cabinet*, *The Atlantic*, *The New Statesman*, *The Guardian*, *The Observer* and many others, in print and online. He lectures regularly at conferences, universities, and other events. His formulation of the New Aesthetic research project has spurred debate and creative work across multiple disciplines.

jamesbridle.com

booktwo.org

Emma Charles is a London-based artist. Working with photography, sound and moving image, her practice explores the way contemporary value systems of time, productivity and labor are altered through technological progress. Recently Emma has situated her research towards the materiality of the Internet, going beneath the urban veneer to uncover the hidden infrastructures within our technologically driven modern life. Emma holds a MA in Photography from Royal College of Art. She has exhibited and screened at Jerwood Visual Arts, London; Serpentine Galleries, London; ZKM, Karlsruhe; HKW, Berlin; Jeu de Paume, Paris; LUX and ICA, London. She is the recipient of a 2016 Arts Council England award, ZKM commission and has been published in *Reset Modernity!* edited by Bruno Latour (MIT Press).

emma-charles.com

As an artist, filmmaker, networker, **Shu Lea Cheang** constructs networked installations and multi-player performances in participatory impromptu mode. She drafts sci-fi narratives in her film scenario and artwork imagination. She builds social interfaces with transgressive plots and open network that permits public participation. Engaged in media activism for two decades (the 80s and 90s) in New York City, Cheang concluded her NYC period with a cybernoia film *FRESH KILL* (1994) and the first Guggenheim museum web art commission/collection *BRANDON* (1998–1999). Since her relocation to the Eurozone in 2000, Cheang has taken up large scale installations and networked performances while she also co-founded several collectives to pursue cross-disciplinary projects. In 2017, Cheang premiered her cypherpunk movie *FLUIDØ* at Berlinale. She has in development two new works: *UKI, cinema interrupted* and *Ultra Love Songs for the Unborn*.

mauvaiscontact.info

Manolis Daskalakis-Lemos lives and works in Athens and Paris. In his work, he uses a variety of media to focus on the ways we dream about tomorrow, but also on examples of former states of prosperity that deteriorated, and how these could be projected onto the future. The contrast between idealism and pragmatism is a recurring theme in his works, which often start from an autobiographical point. Solo exhibitions include *Tomorrow's Corporate Love (Forgetting from Athens)*, Palais de Tokyo, Paris, 2017; *Crooked Grid Crude Carrier*, CAN Christina Androulidaki gallery, Athens, 2015; *Feral Remnants/Oinousses*, CAN Christina Androulidaki gallery, Athens, 2013. Group exhibitions include *The Equilibrists*, a collaboration of the New Museum with Deste Foundation, Benaki Museum, Athens, 2016; *Filter Bubble*, UMA/Westbau, Zurich, 2015; *Poetry will be made by all*, LUMA/Westbau, Zurich, 2014; *Afresh: A new generation of Greek artists*, National Museum of Contemporary Art, Athens, 2013.

Design Earth is led by **Rania Ghosn** and **El Hadi Jazairy**. The design-research practice examines the geographies of technological systems to open aesthetic and political concerns for architecture and urbanism. Their work is widely recognized, including a Young Architects Prize from the Architectural League of New York. They received the Association of Collegiate Schools of Architecture Faculty Design Awards (2017 and 2014), a Jacques Rougerie Foundation's First Prize (2015), and honorable mentions for their competition entries in *City Vision*, *Organic Skyscraper*, *Architect Dry Futures*, and *The Architect's Newspaper* Best of Design Awards in Architectural Representation. Design Earth has exhibited internationally at Venice Biennale of Architecture, Oslo Architecture Triennale, Lisbon Architecture Triennale, Parsons School for Design,

MIT Keller Gallery, and Surssock Museum in Beirut. They are authors of *Geographies of Trash* (ACTAR, 2015) and *Two Cosmograms* (MIT SAP, 2016). Some of their recent writings are published in *Harvard Design Magazine*, *Pidgin, Volume*, *Journal of Architectural Education*, *San Rocco*, *MONU*, *Avery Review*, *Thresholds*, *Bracket*, and *Perspecta*. Ghosn is currently Assistant Professor of architecture and urbanism at Massachusetts Institute of Technology, and Jazairy is Assistant Professor at the University of Michigan Taubman College of Architecture and Urban Planning.

design-earth.org

Constantinos A. Doxiadis (1913–1975) studied architecture in Athens and Berlin. He taught at the National Technical University of Athens and at various universities in the USA and the UK. He played a leading role in the post-war reconstruction of Greece as Director General, Under Secretary and Minister–Coordinator in the first post-war governments. In 1951, he founded Doxiadis Associates, which undertook numerous regional, town planning and building design projects across Asia, Africa, Latin America, the USA and Greece. He also founded the Athens Technical Organization and the Athens Center of Ekistics which developed educational and research activities. Among his works are: the plans and programs for Islamabad, Pakistan; the national housing program of Iraq and the plans and programs for Baghdad; the research and program for the development of the Detroit area; the urban renewal and development plan of the Eastwick area in Philadelphia. He was the author of numerous articles and books.

doxiadis.org

Thomas Doxiadis is an architect and landscape architect. He was Section Manager of the Athens Olympics Organizing Committee (1999–2003), responsible for landscape and the Look of the City. He is currently Chair of the Natural Environment council of the Greek Society for Natural and Cultural Preservation. He has taught at the University of Patras (2003–2007) and has written about ecology, landscape and the city. He is the founder of the architecture & landscape practice doxiadis+ which addresses design on the basis of environmental and landscape ecology principles. His practice has received a Commendation in the 2010 *Architectural Review* Emerging Architecture Awards.

doxiadisplus.com

Farzin Farzin was founded in 2008 by **Farzin Lotfi–Jam**. The multidisciplinary studio investigates the means by which objects, sites and systems acquire cultural value, and examines the representation of value in architectural form. Lotfi–Jam is an

Adjunct Professor of Architecture at Columbia University, and holds advanced degrees from Columbia University and RMIT University in Melbourne, Australia.

farzinfarzin.com

New Affiliates is a New York based multi-scalar design practice led by **Ivi Diamantopoulou** and **Jaffer Kolb**. The studio learns through building, experimenting with loose forms, rough materials, and ornate object stories. Diamantopoulou holds a Master of Architecture from Princeton University and a Diploma in Architectural Engineering from the University of Patras in Greece. Kolb holds a Master of Architecture from Princeton University, a Master of Science in Urban Planning from the London School of Economics, and a Bachelor of Arts from Wesleyan University. They teach at Rensselaer Polytechnic Institute and Princeton School of Architecture, respectively.

new-affiliates.us

jafferkolb.com

lvivivi.net

Kyriaki Goni is a Greek media artist and researcher. Her work focuses on the (im)materiality of forgetting and remembering, digital data distribution and ownership, privacy and the entwine of machine and human memory. Besides her graduate and postgraduate studies on Fine and Digital Arts, she has previously received academic training as a cultural anthropologist. Her artistic practice, combined with research, incorporates various media, technological and anthropological tools and a poetic approach, and investigates the convergence of politics and technology. Her work is presented at galleries and festivals internationally (NEON, Athens Biennale, ISEA, SIGGRAPH, Athens Digital Arts Festival etc.). She holds talks and workshops (Ars Electronica & Onassis Culture Centre, SIGGRAPH, hackerspace.gr, Athens Science Festival, Athens University etc.).

kyriakigoni.com

Penelope Haralambidou is a Senior Lecturer at Bartlett School of Architecture, UCL, and an acting director of the MPhil/PhD Architectural Design programme and MArch Unit 24 coordinator. Her work lies between practice and theory. She has used filmmaking and architectural design as a research method, and her projects have been exhibited internationally. Her monograph, *Marcel Duchamp and the Architecture of Desire*, was published by Routledge (2013), and she has contributed writing on themes such as allegory, figural theory, stereoscopy and film in architecture to a wide range of publications. Her recent research focuses on what she has defined as the architectural essay film. She has organized the symposiums *Architecture | Essay | Film*, 2016, at UCL, and *Film*

| Making | Space, February 2017, at the Royal Academy, and is the author of “The Architectural Essay Film” (ARQ, volume 19, issue 03, 2015), and “With–Drawing Room on Vellum” (*Drawing Futures*, UCL Press, 2016).

Unit 24 is a postgraduate unit at Bartlett School of Architecture, UCL, taught by Penelope Haralambidou, Michael Tite and Simon Kennedy. The unit employs film, video, animation, drawing and virtual/physical modelling techniques to propose ideas that rethink architectures relationship to time and grasp glimpses of its future.

unittwentyfour.com

Adam Harvey is an artist and independent researcher based in Berlin. His work includes developing camouflage from face detection (*CV Dazzle*, 2010), anti-drone garments (*Stealth Wear*, 2013), a faraday cage phone case (*OFF Pocket*, 2013), and a Wi-Fi geolocation spoofing device (*SkyLift*, 2016). Harvey's multidisciplinary approach to exploiting surveillance technologies has been widely noted in a wide range of publications from *The New York Times* to the *Air Force Times*. He has been nominated as a Future Great by *Art Review* magazine in 2014, received a Core77 design award in 2011 for his work on *CV Dazzle*, and was recently awarded a web-residency by Schloss Solitude and ZKM for continued development of *SkyLift*. Harvey's current work continues to explore low-cost methods for averting high-tech surveillance.

ahprojects.com

The **Interactive Architecture Lab** is a multi-disciplinary research group at the Bartlett School of Architecture (UCL) led by Ruairi Glynn. Research revolves around the behaviour and interaction of Things, Environments and their Inhabitants. At the heart of the Lab is its 15-month master's programme that gives students an opportunity to discover the potential of new sensing, computation, networked and responsive technologies.

Ava Aghakouchak is an architectural designer/interaction designer and a member of the Interactive Architecture Lab. She currently is a PhD candidate at the Bartlett School of Architecture, UCL, where she aims to carry out her research focused on the interactions between the human body and built environments, and possible future human-machine relationships. Ava examines her ideas about the future of wearable technologies by looking at the current state of mobile devices and 3D vision systems, and considering how these technologies could change the way humans see and interact with the world around them.

Maria Paneta is a Greek architect and designer, holding a Master's Degree in Architectural Design from the Bartlett School of Architecture, UCL. She is working on the verge of art and

architecture with an interest in cybernetics, interaction and cognition. Her practice focuses on installation design engaging with scientific research, artistic expression and smart technology applications. She is exploring new ways of sensing space using wearables and large-scale aesthetic installations. Her study at the Bartlett resulted in the development of the wearable *Sarotis*, a prosthetic device that augments spatial awareness and an empirical experiment on the binding process.

interactivearchitecture.org

Lydia Kallipoliti is an architect, engineer and scholar, currently an Assistant Professor of Architecture at Rensselaer Polytechnic Institute and at the Center for Architecture, Science and Ecology in New York. Her work has been displayed, among other venues, at the Venice Biennale, the Istanbul Design Biennial, the Shenzhen Biennale, the Storefront of Art and Architecture, RIBA and the Disseny Hub Barcelona, and published in *Architectural Design, Log, Praxis, Thresholds, Future Anterior* and *e-flux*. She is the recipient of awards, including the ACSA award for creative achievement, grants from the Graham Foundation and the New York State Council for the Arts, the Lawrence Anderson Award for the creative documentation history, a Fulbright scholarship and the W3 Medal for environmental awareness. Kallipoliti holds a SMArchS from MIT and a PhD from Princeton University. She is the principal of ANAcycle thinktank, EcoRedux research network and the author of the forthcoming book *Closed Worlds, Or, What is the Power of Shut*.

anacycle.com
ecoredux.com

Andreas Theodoridis is a PhD candidate at the Center of Architecture, Science and Ecology [CASE] of Rensselaer Polytechnic Institute in New York. He is an architect specializing in building systems and air pollution, having received a diploma in architecture and engineering from the Aristotle University of Thessaloniki and an MS in Sustainable Environmental Systems from Pratt Institute. He has fifteen years of experience in building and construction through the office he founded in Athens, 207x207 architecture network along with Stella Nikolakaki. Since 2010, he has been living and working in New York, has taught building systems at Syracuse University and Columbia University, and has worked as a consultant for the Cooper Union Institute of Sustainable Design.

207x207.net

Erica Vinson, **Xueping Li**, **Seraphem Le** and **Dakota Pace** are students of architecture at Rensselaer Polytechnic Institute in New York.

Demetra Katsota is a registered architect, Associate Professor of Architectural Design at the Department of Architecture,

University of Patras, and founding partner of buerger katsota architects. Demetra received her Diploma in Architecture from the Architectural Association School of Architecture and MArch from Harvard University's Graduate School of Design.

Stephan Buerger is a registered architect, founding partner of buerger katsota architects. Born in Austria, Stephan received his Diploma in Architecture with Honours from the Architectural Association School of Architecture and MArch from the Harvard Graduate School of Design.

The work of **buerger katsota architects** has been widely published and exhibited in Europe and beyond. Notably, in 2014 and 2012, the practice participated in the Venice Biennale of Architecture.

The practice has received several awards and honours. They were twice nominated for the European Union Prize for Contemporary Architecture – Mies van den Rohe Award (2013, 2015). They are recipients of the Public and Common Use Award 2013 of the Hellenic Institute of Architecture and the Architecture Abroad Award 2010 of the Union of Greek Architects.

buerger-katsota.com

Zissis Kotionis is a PhD architect, artist and writer, Professor at the Department of Architecture, University of Thessaly. He has published eight books on architectural theory, urban culture and narrative poetry. His architectural and art projects have been published, exhibited and awarded internationally. His work includes artistic performances, installations, exhibitions and public art practices.

kotionis.com

Shannon Mattern is an Associate Professor of Media Studies at The New School. Her writing and teaching focus on archives, libraries, and other media spaces; media infrastructures; spatial epistemologies; and mediated sensation and exhibition. She is the author of *The New Downtown Library: Designing with Communities*, *Deep Mapping the Media City*, and *Code and Clay, Data and Dirt: Five Thousand Years of Urban Media* (forthcoming), all published by University of Minnesota Press. She also contributes a regular long-form column about urban data and mediated infrastructures to *Places*, a journal focusing on architecture, urbanism and landscape, and she sometimes collaborates on public design and interactive projects and exhibitions.

wordsinspace.net

Founded by **Vinca Kruk** and **Daniel van der Velden**, **Metahaven** is a collective working across design, art and filmmaking. Recent solo presentations include *Information Skies*, Auto Italia, London (2016);

The Sprawl, YCBA, San Francisco (2015); *Black Transparency*, Future Gallery, Berlin (2014); and *Islands in the Cloud*, MoMA PS1, New York (2013). Recent group exhibitions include *Fear & Love*, Design Museum, London (2016); *Dream Out Loud*, Stedelijk Museum, Amsterdam (2016); *The Eighth Climate (What Does Art Do?)*, the 11th Gwangju Biennale (2016); *All of This Belongs to You*, Victoria & Albert Museum, London (2015); *Private Settings: Art After the Internet*, Museum of Modern Art, Warsaw (2014); and *Frozen Lakes*, Artists Space, New York (2013). Recent publications include *Black Transparency* (2015), *Can Jokes Bring Down Governments?* (2013), and *Uncorporate Identity* (2010). Music videos by Metahaven include "Home" (2014), and "Interference" (2015), both for musician, composer and artist Holly Herndon, as part of an ongoing collaboration. Metahaven's have shot the first full-length documentary, *The Sprawl (Propaganda about Propaganda)* (2016) and the short film *Information Skies* (2016).

metahaven.net

The New Raw (TNR) is a creative practice that explores the merging fields of digital fabrication and material resourcing. TNR's projects focus on creating closed loops by introducing digital fabrication technologies in the recycling process of discarded materials. In this manner, the studio explores what design can do for waste-overproduction and material misuse. The New Raw was founded in Rotterdam in 2015 by Foteini Setaki and Panos Sakkas.

thenewraw.org

Stefania Strouza is an artist and architect living and working in Vienna and Athens. Her artistic practice is based on the idea of the Eastern Mediterranean region as the merging point of diverse cultural currents, between the East and the West, the archaic and the modern. In her current research, she focuses on the notion of the shore as a physical and conceptual site, both in terms of its materiality as well as its geopolitical and symbolic implications. Part of this ongoing project was developed during her residency at the Seeger Center for Hellenic Studies of Princeton University.

stefaniastrouza.com

Formed in 2011, **pneumastudio** is an experimental design practice that brings together the related fields of architecture and landscape architecture as a means of reconsidering the 'built environment' in a time of environmental crisis and existential threat. *pneumastudio* has exhibited its work at the Design Museum of Barcelona, New York University's Gallatin School of Individualized Study, and the Storefront for Art and Architecture in New York. Cathryn Dwyre and Chris Perry are fellows of The MacDowell Colony (2013) and co-editors of a special issue of *PAJ: A Journal*

of Performance and Art (MIT Press). Recent publications featuring the group's work include *Global Design* (Prestel), *Architecture Inserted* (Yale School of Architecture), and *XXL-XS: New Directions in Ecological Design* (Actar).

Cathryn Dwyre is Visiting Associate Professor at Pratt Institute's School of Architecture where she teaches seminars and design studios in the Degree Project undergraduate thesis sequence as well as elective history/theory seminars on architecture and landscape. Dwyre is also a regular contributor to *The Architect's Newspaper* for which she writes book reviews on landscape architecture.

Chris Perry is Associate Professor at Rensselaer Polytechnic Institute's School of Architecture where he is Head of Graduate Studies, director of the Geofutures Master of Science in Architecture post-professional program, and coordinator of the Final Project undergraduate thesis sequence. Prior to joining the faculty at Rensselaer, Perry was the Louis I. Kahn Visiting Assistant Professor at the Yale School of Architecture.

pneumastudio.org

Point Supreme was founded by **Konstantinos Pantazis** and **Marianna Rentzou** in 2008 after working in London, Rotterdam, Brussels and Tokyo. They regularly publish self-initiated studies and projects for Athens, where they are based. Their research and projects for the contemporary city were exhibited in the Greek Pavilion at the Venice Biennale of Architecture in 2012 under the title 'Made in Athens.' That same year they were acclaimed by the popular Greek newspaper *LIFO* amongst the 20 most influential personalities in Greece and were listed in *Wallpaper** magazine's *Architects Directory for 2015*. *Athens Projects*, the first book dedicated to their work was published as part of the Treatise Series in 2015 by Graham Foundation in Chicago. In 2017, they were curators of the episode 'After Utopia,' part of the 25th Ljubljana Biennale of Design: "Faraway So Close."

pointsupreme.com

Tobias Revell is an artist and designer. Spanning different media and genres, his work addresses failed utopias, rogue actors, unexplained phenomena, and the idea of technology as territory. Tobias is Senior Lecturer in Critical and Digital Design at the London College of Communication, UAL. He is a co-founder of research consultancy Strange Telemetry and one-half of research and curatorial project Haunted Machines. He lectures and exhibits internationally, and has recently appeared at Improving Reality, FutureEverything, Impakt Utrecht, Web Directions Sydney, transmediale Berlin and Lift Geneva. He is a PhD candidate in design at Goldsmiths.

tobiasrevell.com

Georgina Voss is a technology anthropologist, artist and writer, whose work focuses on the political and infrastructural systems which underpin and shape technological practices, and the spatial elements of these relationships. Her work has been commissioned and exhibited by the Brighton Digital Festival, UK; Artefakt Festival, Leuven; and the Milton Keynes International Festival, UK; and she has held artistic residencies at RAMLAB, Rotterdam Port; Experimental Research Lab in Autodesk's Pier 9, San Francisco; and Lighthouse Arts, Brighton. Voss holds a PhD in Science and Technology Studies from the Science Policy Research Unit (SPRU), University of Sussex. Her writing has been published in *The Atlantic*, *The Guardian*, and *HOLO Magazine*, and she is the author of *Stigma and the Shaping of the Pornography Industry* (Routledge 2015). She is a co-founder and director of research studio Strange Telemetry, and a senior lecturer and research lead in critical studies and design at the University of the Arts, London.

georginavoss.com

Bruce Sterling is an author, journalist, editor and critic. Best known for his ten science fiction novels, he also writes short stories, book reviews, design criticism, opinion columns and introductions for books. His nonfiction works include *The Hacker Crackdown: Law and Disorder on the Electronic Frontier* (1992), *Tomorrow Now: Envisioning the Next Fifty Years* (2003), *Shaping Things* (2005), and *The Epic Struggle of The Internet of Things* (2014). His most recent book is a collection of Italian fantascienza stories, *Utopia Pirata: I Racconti di Bruno Argento* (2016). He has been 'Visionary in Residence' at the Art Center College of Design in Pasadena (2005, 2011), the Sandberg Instituut in Amsterdam (2008), the Center for Science and the Imagination at Arizona State University (2013), and the Arthur C. Clarke Center for Human Imagination (2016). In 2008 he was the Guest Curator for the Share Festival of Digital Art and Culture in Torino, Italy, and in 2015 he was the Curator of the 'Casa Jasmina' project at the Torino Fab Lab.

Vassiliea Stylianidou works as a video and installation artist, using in her works related artistic media such as text, sound/music and performance. Her artistic process involves a constant renegotiation of public and private history, as well as public and private spaces. Her works deal with the limits inherent in systems of order and discipline such as architecture, body, power, family, gender and language. Her work has been exhibited at nGbK, Berlin; quartier21/MuseumsQuartier, Vienna; Haus der Kulturen der Welt, Berlin; Fotohof, Salzburg; VCA Margaret Lawrence Gallery, Melbourne; Onassis Cultural Centre, Athens; Macedonian Museum of Contemporary Art, Thessaloniki; KW, Berlin; The National Museum

for Contemporary Art, Athens; State Museum of Contemporary Art, Thessaloniki; Art in General, NYC and in other venues. She has also participated in the Prague Biennale and in the parallel programme of the Athens and Thessaloniki Biennials. She lives and works in Berlin and Athens.

stylianidou.com

Lina Theodorou lives between Berlin and Athens, working primarily through video and installations. She studied at the School of Graphic Arts and Creative Studies, Athens; the School of Fine Arts of Athens; and the School of Fine Arts, Hague, The Netherlands (Sculpture and Multimedia). She has participated in shows at Bozar, center for fine arts, Brussels; National Museum of Contemporary Art, Athens; EMAF, European Media Art Festival, Osnabrück, Germany; Deste Foundation, Athens; Neue Galerie am Landesmuseum Joanneum, Graz, Austria; Museum Fridericianum, Kassel, Germany; Macedonian Museum of Contemporary Art, Thessaloniki; 53rd International Short Film Festival Oberhausen, Germany; 11th International Architecture Exhibition Venice Biennale; Impakt festival, Utrecht; State Museum of Contemporary Art, Thessaloniki; Benaki Museum, Athens; Onassis Cultural Centre, Athens; Museumsquartier, Vienna, and in other venues.

linatheodorou.com

Zenovia Toloudi is an architect and artist, Assistant Professor at Studio Art, Dartmouth College. In 2000, Toloudi founded **Studio Z**, a research and art-architecture practice. Her installations have been exhibited internationally, including Venice Biennale, The Lab at Harvard, Dartmouth, MIT, and Athens Byzantine Museum. Her public art projects have been placed in Fenway Boston, the lobby of MIT Stata and the central entrance of two buildings in New England of Optometry in Boston. Other works of her belong to permanent collections such as Aristotle University's Sculpture Collection, Threcian Pinacotheca and Leslie Center for the Humanities, at Dartmouth. Her essays have been published in Routledge, *Technoetic Arts*, *MAS Context* and *WAR* journals. Toloudi has received a Doctor of Design degree from Harvard GSD, a Master of Architecture from Illinois Institute of Technology (as a Fulbright Fellow), and a Diploma in Architectural Engineering from Aristotle University of Thessaloniki.

zenovia.net

"Design Led Futures" is a research initiative at **Victoria University of Wellington** that was co-created by **Ross Stevens** and **Simon Fraser**. It aims to give a more rigorous and challenging tone to the speculative movement often collaborating with industry partners

and researchers. *Birthright* comes from the subset *Future under Negotiation*, or *FUN*, which is an undergraduate course aimed at gauging the ideology and opinions of our future designers. It emphasizes to students that the future is not a pre-ordained dystopia, but more importantly, it is determined by how we act and negotiate now and that if we get it right the future will simply be *FUN*, which is the one thing we know we want.

designedfutures.com

Pinar Yoldas is a cross-disciplinary artist and researcher. Her work develops within biological sciences and digital technologies through architectural installations, kinetic sculpture, sound, video, with a distinct focus on posthumanism, eco-nihilism, the Anthropocene, and feminist technoscience. She holds a PhD from Duke University, an MFA from UCLA, MS (ITU), MA (Bilgi University), BArch (METU). Her solo shows include *The Warm, the Cool and the Cat* at Röda Sten Konsthall (Sweden), the project space of Schering Stiftung in Berlin among many. Group shows include National Art Museum of China in Beijing, transmediale festival in Berlin, Museum Ostwall in Dortmund, PolytechMuseum in Moscow, ZKM in Karlsruhe, the 14th Istanbul Biennial, Nordic Biennial and Taiwan National Museum of Fine Arts. In 2015, she was recipient of a Guggenheim Fellowship in the Fine Arts.

pinaryoldas.info

Liam Young is a speculative architect and filmmaker who operates in the spaces between design, fiction and futures. He is founder of the think tank *Tomorrow's Thoughts Today*, a group whose work explores the possibilities of fantastic, speculative and imaginary urbanisms, and co-runs the Unknown Fields Division, a nomadic research studio that travels on location shoots and expeditions to the ends of the Earth to document emerging trends and uncover the weak signals of possible futures. Liam is a producer of a BAFTA nominated short, has premiered films at the London Film Festival and has been collected by institutions such as the Victoria & Albert Museum, the Museum of Metropolitan Art in New York and the Powerhouse Museum in Sydney.

tomorrowsthoughtstoday.com

Michael Young is an architect and educator practicing in New York City where he is a founding partner of the architectural design studio Young & Ayata. Young & Ayata recently received a first-place prize to design the new Bauhaus Museum in Dessau, Germany. In 2014, they received the Young Architects Prize from the Architectural League of New York and in 2016 the Design Vanguard Award from Architectural Record. Young is Assistant Professor at

the Cooper Union. He has previously taught design studios and seminars at Yale, Princeton, SCI-Arc, Columbia, Syracuse, Pratt, Cornell and Innsbruck University. His work has been exhibited recently in New York, Los Angeles, Istanbul, Chicago, Barcelona and Princeton.

young-ayata.com

Takis Ch. Zenetos (1926-1977) studied architecture in Paris and established his practice in Athens in 1955. An exponent of radical modernism, he is recognized as one of the leading figures of 20th century Greek architecture. Apart from a wide range of prestigious buildings, his work also includes visionary research projects. Among his projects are the Fix Brewery plant, the Secondary school in Aghios Dimitrios, the open-air theatre on Lycabettus hill, the Apartment Building at Amalias Avenue.



The future never felt closer than it does today. A series of environmental, technological and social shifts are affecting today's world and the human's role within it. Continuous urbanization, the impact of the anthropogenic activity on the natural environment, the increasing use of algorithmic systems in all sectors of life, and the growing asymmetries of power among territories and populations, are all central issues at stake. *How possible is it to address the future and how intelligible are the changes already taking place? Which imaginaries and counter-fictions can influence what is yet to come?*

This catalogue is published on the occasion of the exhibition "Tomorrows: Urban Fictions for Possible Futures" organized by Onassis Cultural Centre at the Diplareios School Athens (May 16 – July 16, 2017). The exhibition hosted works by artists, architects and designers that tell stories about how the future might unfold. Their narratives refer to the emergence of post-natural environments, the appearance of new types of shells and co-habitats, the sovereignty of networks and infrastructures, the rise of a new algorithmic society and the challenges of a new condition beyond the primacy of the human. Offering a contextualization, presentation and documentation of the exhibition, this catalogue seeks to spotlight how future can be used as a tool to critically understand present itself.